

AM417 – Ratiometric instrumentation amplifier with adjustable output stage

PRINCIPLE FUNCTION

Integrated instrumentation amplifier with an output stage for the amplification of differential signals and with an internal current source for the supply of external signal sources. The output signal is a voltage between 0.5 and 4.5V, ratiometrical to the supply voltage. The output span could be adjusted by the changeable gain of the output stage.

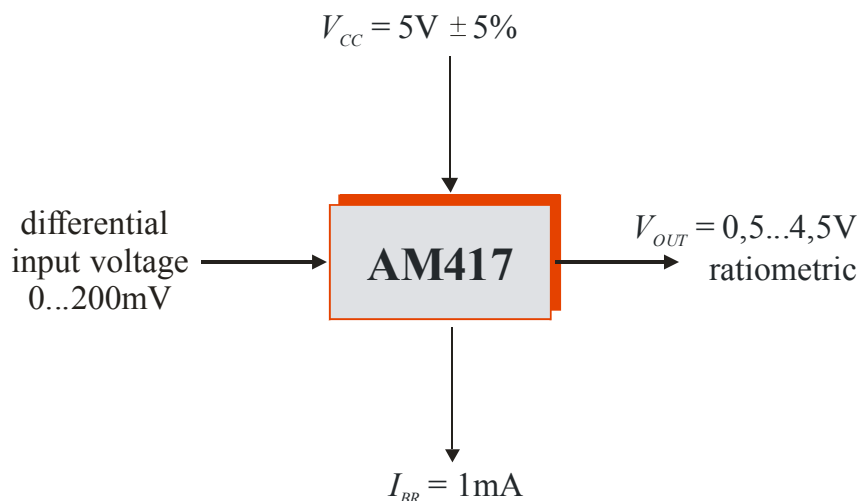

TYPICAL APPLICATIONS

- Amplification of resistor bridge signals
- Voltage measurement e.g. temperature sensors
- Current measurement via Shunt resistors
- Amplification circuitry for sensing elements e.g. silicon pressure sensing elements
- Differential input circuit for microprocessors/ADC-applications
- Automotive bridge signal conditioning

analog microelectronics
integrated circuits

Analog Microelectronics GmbH
An der Fahrt 13, D – 55124 Mainz

Phone: +49 (0)6131/91 073-0
Fax: +49 (0)6131/91 073-30
Internet: <http://www.analogmicro.de>
Email: info@analogmicro.de

AM417 – Ratiometric instrumentation amplifier with adjustable output stage

CONTENTS

PRINCIPLE FUNCTION	1
TYPICAL APPLICATIONS	1
FEATURES	3
BLOCK DIAGRAM	3
ELECTRICAL SPECIFICATIONS	4
BOUNDARY CONDITIONS / EXTERNAL COMPONENTS	5
DESCRIPTION OF FUNCTIONS	6
Instrumentation amplifier	6
Current source	6
Output stage	6
CALIBRATION WITH A RESISTOR BRIDGE CIRCUIT	7
Setting the output span	7
Setting the output offset	7
EXAMPLES	10
Example 1: Piezoresistive pressure sensing element in a bridge circuit with a positive offset	10
Example 2: Piezoresistive pressure sensing element in a bridge circuit with a negative offset	11
Example 3: Piezoresistive pressure sensing element in a bridge circuit with a high positive offset	12
TEMPERATURE COMPENSATION OF THE OUTPUT SPAN	13
EXAMPLE	15
Example 4: TCS compensation of a piezoresistive pressure sensing element	15
BLOCK DIAGRAM AND PINOUT	16
DELIVERY	16
EXAMPLE APPLICATIONS	17
FURTHER READING	18

AM417 – Ratiometric instrumentation amplifier with adjustable output stage

FEATURES

- Instrumentation amplifier input for positive input voltages: 0...200mV
- Adjustable gain
- Common mode input range (CMIR): 1.3... $V_{CC} - 2.2V$
- Output voltage ratiometric to the supply: 0.5...4.5V
- Low offset
- Low offset drift
- Supply voltage range: $5V \pm 5\%$ (ratiometric range)
- Wide operating temperature range: $-40^{\circ}C...+125^{\circ}C$
- Ratiometric current source for the supply of external measuring cells
- Output driver (PNP open collector): $I_{OUT} = +11mA$
- No limited resolution
- Output current limitation
- Low internal noise
- Integrated EMC protection
- Small SO8 package
- Low cost

DESCRIPTION

AM417 is a low-cost ratiometric interface IC which has been specifically designed for the conditioning of differential signals. The IC is particularly suitable for the signal evaluation of sensor elements which have to be powered by an internal current source (OP). These include piezoresistive and magnetoresistive silicon measuring cells and temperature sensing elements based on a resistor setup. In essence AM417 consists of a precision instrumentation amplifier, a ratiometric operational amplifier and a protected voltage output which has been configured as a driver stage. The amplifier can be adjusted across a wide range using two external resistors and the offset of an additional resistor affixed to the measuring bridge.

Precision amplifier AM417 has been engineered in such a way that it can be used as an instrumentation amplifier for follow-on processors or A/D converters to make optimum use of the converter range.

BLOCK DIAGRAM

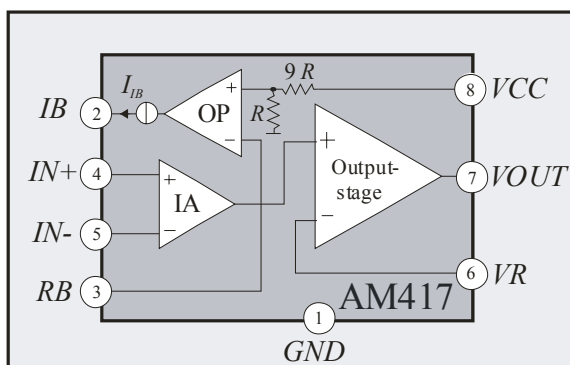

Figure 1: Block diagram of AM417.

analog microelectronics
integrated circuits

Analog Microelectronics GmbH
An der Fahrt 13, D – 55124 Mainz

Phone: +49 (0)6131/91 073-0
Fax: +49 (0)6131/91 073-30
Internet: <http://www.analogmicro.de>
Email: info@analogmicro.de

AM417 – Ratiometric instrumentation amplifier with adjustable output stage

ELECTRICAL SPECIFICATIONS

$T_{amb} = 25^{\circ}\text{C}$, $V_{CC} = 5\text{V}$ (unless otherwise stated). Currents flowing into the IC are negative.

Symbols in the table refer to *Figure 1* and *Figure 2*.

Parameter	Symbol	Conditions	Min.	Typ.	Max.	Unit
System Parameters*						
Supply Voltage Range	V_{CC}	Ratiometric range	4.75	5	5.25	V
Maximum Supply Voltage	V_{CCmax}				6	V
Quiescent Current	I_{CC}	$V_{CC} = 5\text{V}$, $R_1 = 500\Omega$, $I_{IB} = 1\text{mA}$			7.6	mA
Temperature Specifications						
Operating temperature	T_{amb}		-40		125	$^{\circ}\text{C}$
Storage temperature	T_{st}		-55		125	$^{\circ}\text{C}$
Junction temperature	T_J				150	$^{\circ}\text{C}$

Parameter	Symbol	Conditions	Min.	Typ.	Max.	Unit
OP (Ratiometric Current Source)						
Input Voltage	V_{RB}	Ratiometric with $V_{CC} = 5\text{V}$		0.5		V
Input current	I_{RB}			100		nA
Output Current Range	I_{IB}		0.50		1.25	mA
Output Current accuracy	I_{IB}	Ratiometric with $V_{CC} = 5\text{V}$, $R_1 = 500\Omega$	0.98	1	1.02	mA
Ratiometric Error	$RAT@IB$	$RAT@IB = 1.05 V_{RB} (V_{CC} = 5\text{V}) - V_{RB} (V_{CC} = 5.25\text{V})$	-1		1	mV
I_{IB} vs. temperature	dI_{IB}/dT	$I_{IB} = 1\text{mA}$	-45	-25	-5	ppm/ $^{\circ}\text{C}$
I_{RB} vs. temperature	$\square dI_{RB}/dT$	$I_{IB} = 1\text{mA}$	-20		+20	ppm/ $^{\circ}\text{C}$
Output Voltage Range	V_{IB}	$I_{IB} = 1.25\text{mA}$	2.0		$V_{CC}-0.2\text{V}$	V
Output Resistance	R_{IB}	$R_{IB} = V_{IB}/I_{IB}$, $V_{IB} = 2\text{V}$, $\Delta V_{IB} = 2.8\text{V}$, $I_{IB} = 1\text{mA}$,	1.5	30		M Ω

Instrumentation Amplifier						
Common Mode Input Voltage Range	$CMIR$		1.3		$V_{CC}-2.2\text{V}$	V
Differential Input Voltage Range	ΔV_{IN}		0		200	mV
Internal Gain	G_{IA}		9.8	10.0	10.2	
Input Bias Current	$I_{IN+/-}$			25	75	nA
Input Offset Voltage	V_{OIA}		-3		3	mV
V_{OS} vs. temperature	dV_{OIA}/dT	$T_{amb} = -40 \dots 100^{\circ}\text{C}$	-10		10	$\mu\text{V}/^{\circ}\text{C}$
V_{OS} vs. temperature	dV_{OIA}/dT	$T_{amb} = 100 \dots 125^{\circ}\text{C}$	-30		30	$\mu\text{V}/^{\circ}\text{C}$
Output Voltage Range	V_{VIA}		0.05		$V_{CC}-2\text{V}$	V
Nonlinearity	NL_{IA}	$V_{IN-} = 1.3\text{V}$, $\Delta V_{IN} = 100\text{mV}$, 200mV			0.15	% FS
Common Mode Rejection Ratio	$CMRR$	$V_{IN-} = 1.3\text{V}$, $\Delta V_{IN} = 100\text{mV}$	80	90		dB
Power Supply Rejection Ratio	$PSRR$	$V_{IN-} = 1.3\text{V}$, $\Delta V_{IN} = 100\text{mV}$	74	80		dB
Input Voltage Noise	e_n	$G_{IA} = 10$		35		nV/ $\sqrt{\text{Hz}}$

AM417 – Ratiometric instrumentation amplifier with adjustable output stage

Parameter	Symbol	Conditions	Min.	Typ.	Max.	Unit
Voltage Output Stage						
Adjustable Gain	G_{OUT}		2		11	
Input Voltage Range	V_{VR}		0.05		$V_{CC} - 2.25V$	V
Input Current	I_{IN}	$V_{IN-} = 2V, \Delta V_{IN} = 50mV$		20	75	nA
Input Offset Voltage	V_{OS}		-3		3	mV
V_{OS} vs. temperature	dV_{OS}/dT	$V_{IN-} = 2V, \Delta V_{IN} = 50mV,$ $T_{amb} = -40...100^{\circ}C$	-15		15	$\mu V/^{\circ}C$
V_{OS} vs. temperature	dV_{OS}/dT	$V_{IN-} = 2V, \Delta V_{IN} = 50mV,$ $T_{amb} = 100...125^{\circ}C$	-100		0	$\mu V/^{\circ}C$
Output Current	I_{VOUT}	Pin V_{OUT}	65	150	350	μA
Output Voltage Range	V_{OUT}	With external transistor*	0.5		4.5	V
Output Current	I_{OUT}	With external transistor*			11	mA
Output Resistance	R_{OUT}	With external transistor*		0.1	0.85	Ω
Power Supply Rejection Ratio	$PSRR$		-72	-90		dB
Current Limitation Threshold	V_{THRESH}	$V_{THRESH} = V_{VCC} - V_{VOUTmin}$ $R_2 = 27\Omega, I_{OUT} \approx 14mA$	1.00		1.15	V
V_{THRESH} vs. Temperature	dV_{THRESH}/dT	$-40...+125^{\circ}C$ without external transistor*	-4.2		-1.8	$mV/^{\circ}C$

System Parameters						
Input Voltage Range	ΔV_{IN}	@ $V_{OUTmax} = 4.5V$ and $G_{OUT} = 10$	0		40	mV
	ΔV_{IN}	@ $V_{OUTmax} = 4.5V$ and $G_{OUT} = 2$	0		200	mV
Gain Bandwidth Product	GBW	$C_{OUT} = 1nF$	400	1,500		kHz
Nonlinearity	NL				0.15	%FS

Table 1: Electrical specifications

System parameters: specifications which refer to the AM417 circuit as a whole.

* Output current dependent on resistor R_2 (see Equation 4).

BOUNDARY CONDITIONS / EXTERNAL COMPONENTS

Parameter	Symbol	Conditions	Min.	Typ.	Max.	Unit
Resistor Adjustment Current Source	R_1		400		1000	Ω
Resistor Sense Current Limitation	R_2		0		50	Ω
Gain Resistor Sum	$R_3 + R_4$	$V_{OUT} = (R_3 + R_4)/R_4 G_{IA}$	0:41		2.1	k Ω
Capacitor Power Supply	C_1		100	330		nF
Capacitor Frequency Compensation	C_2	X7R capacitor, $\pm 10\%$	4.7		4.7	nF
Capacitor Load	C_3	X7R capacitor, $\pm 10\%$	1.0		10.0	nF
Output PNP Transistor	β_{T1}	e.g. BCW68H or BC557C, low drop, high β for $T_{amb} = -40...125^{\circ}C$	180			

Table 2: Electrical boundary conditions



Analog Microelectronics GmbH
An der Fahrt 13, D – 55124 Mainz

Phone: +49 (0)6131/91 073-0
Fax: +49 (0)6131/91 073-30
Internet: <http://www.analogmicro.de>
Email: info@analogmicro.de

AM417 – Ratiometric instrumentation amplifier with adjustable output stage

DESCRIPTION OF FUNCTIONS

AM417 is a ratiometric, adjustable interface IC which has been specially developed for the conditioning of bridge signals for automotive applications. With its integrated, ratiometric current source it is particularly suitable for the excitation of piezoresistive bridge devices in a constant current mode. The IC enables simple calibration and temperature compensation of the input signals. AM417 consist of three functional units:

Instrumentation amplifier

Using the input stage of the instrumentation amplifier (IA) the input signal is preamplified by $G_{IA} = 10$. The IA can only process positive input signals. A negative input voltage or negative input offset must be balanced by using additional resistor at positive input pin V_{IN+} (c.f. *Setting the output offset*).

Current source

The additional operational amplifier (OP) is linked internally to supply voltage V_{CC} via a voltage divider (10:1). With the OP acting as a ratiometric current source a resistor measuring cell can be supplied with constant current within a range of 0.5 – 1.25mA.

The supply current of the external sensing element I_{IB} can be set by varying resistor R_1 at the minus input of the OP (V_{IN-}) using the following ratio:

$$I_{IB} = \frac{V_{VCC}}{10 R_1} \quad (1)$$

Output stage

A voltage amplifier with an external PNP open collector stage (T_1) acts as a voltage output and can provide a maximum current of $I_{OUT} = 11\text{mA}$. Using external resistors R_3 and R_4 the Gain G_{OUT} can be adjusted between 2 and 11.

$$G_{OUT} = \frac{R_3 + R_4}{R_4} \quad (2)$$

The gain of the entire circuit AM417 is thus: $G_{SYS} = G_{IA} G_{OUT}$.

A current limitation has been integrated into the output stage. The limit circuit restricts output voltage V_{OUTmin} with reference to V_{CC} , where V_{BE} is the basic emitter voltage of external transistor T_1 .

$$V_{VOUTmin} = V_{VCC} - 1.5 V_{BE}(T_1) \quad (3)$$

With this the maximum output current can be adjusted using resistor R_2 in series with the T_1 transistor emitter (see *Figure 2*). The current is thus calculated as:

$$I_{OUTmax} = \frac{V_{THRESH} - V_{BE}(T_1)}{R_2} \approx \frac{380\text{mV}}{R_2} \quad (4)$$

AM417 – Ratiometric instrumentation amplifier with adjustable output stage

where V_{THRESH} is current limitation threshold.

Should no current limit be necessary, the T_1 transistor emitter can be directly connected up to pin VCC ($R_2 = 0$). Good thermal coupling between T_1 and the IC reduces the temperature drift of output current I_{OUT} , thus raising the quality of the current limit.

The output stage is not protected against reverse polarity. Reverse polarity of VCC referenced to ground can be realized using a simple additional circuit, see [3].

CALIBRATION WITH A RESISTOR BRIDGE CIRCUIT

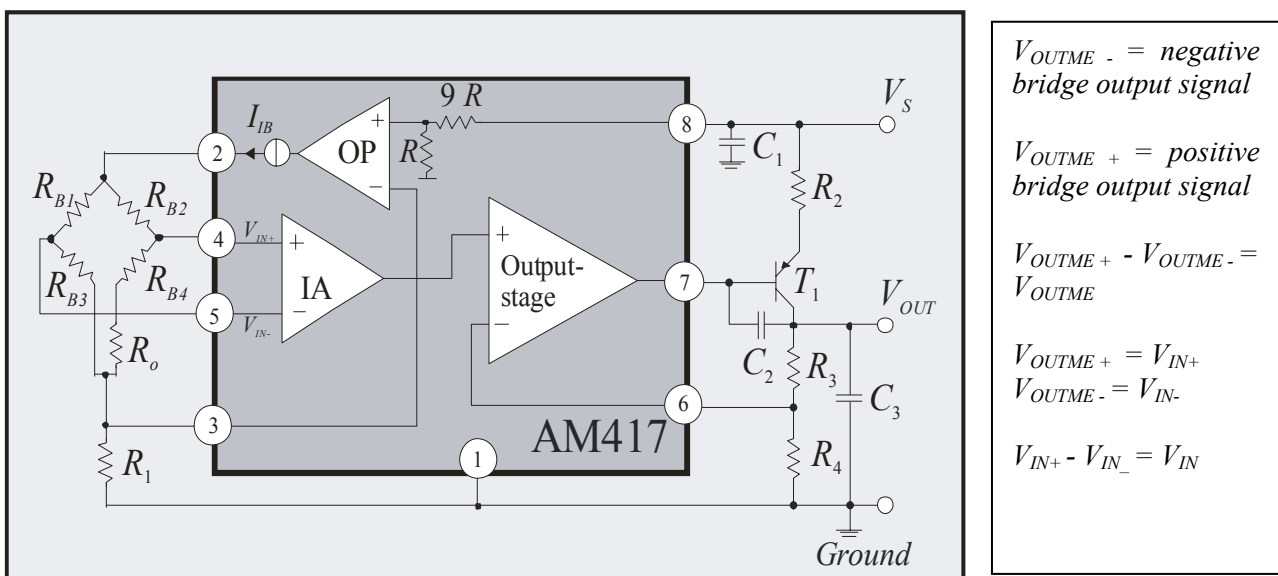

Figure 2: Measuring a constant-current sensing element using a Wheat-

Setting the output span

The output signal span can be set using gain G_{OUT} of the output stage (see Equation 2):

$$G_{OUT} = \frac{V_{SPAN}}{V_{OUTME} \cdot G_{IA}} \quad (5)$$

where $V_{SPAN} = V_{OUTmax} - V_{OUTmin}$ and V_{OUTME} is the output voltage of the sensing element.

Setting the output offset

In a Wheatstone bridge circuit, such as those frequently used with piezoresistive sensors, the offset of the output voltage V_{OUTmin} must be calibrated depending on the required degree of accuracy and with reference to the offset of both the sensing element and the IC. To this end, a compensating

AM417 – Ratiometric instrumentation amplifier with adjustable output stage

resistor R_O is inserted into the measuring bridge (see *Figure 2*). By using this compensating resistor the instrumentation amplifier input voltage ΔV_{IN} is set in such a way, that output voltage V_{OUTmin} has a value of 0.5V, for example. The voltage drop V_{RO} across resistor R_O is given by:

$$V_{RO} = \left[\Delta V_{IN} - V_{BR} \left(\frac{R_{B4}}{R_{B3} + R_{B4}} - \frac{R_{B2}}{R_{B1} + R_{B2}} \right) \right] / \left(1 - \frac{R_{B3}}{R_{B3} + R_{B4}} \right) \quad (6)$$

where V_{BR} is the voltage drop across the entire sensing element, R_{BR} the total bridge resistance and $R_{B1,2,3,4}$ the individual bridge resistors. Assuming that the four separate bridge resistors have the same value, the following approximation formula is valid:

$$V_{RO} = 2\Delta V_{IN} \quad (7)$$

ΔV_{IN} is the voltage to be set at the input of the instrumentation amplifier where there are no offsets.

$$\Delta V_{IN} = \frac{V_{OUTmin}}{G_{SYS}} = \frac{V_{OUTmin}}{G_{IA} \cdot G_{OUT}} \quad (8)$$

Taking the offset of the sensing element (V_{OSME}) and that of the IC (V_{OSIC}) into account ($V_{OSIC} = V_{OSIA} + 0.1V_{OSOUT}$, where V_{OSIA} is the instrumentation amplifier offset and V_{OSOUT} the output stage offset), the adjustable voltage is calculated as:

$$\Delta V_{IN}' = \Delta V_{IN} - V_{OSIC} - V_{OSME} \quad (9)$$

From (9) and (8) it follows that:
$$\Delta V_{IN}' = \frac{V_{OUTmin}}{G_{IA} \cdot G_{OUT}} - V_{OSIC} - V_{OSME} \quad (10)$$

Applying (7) and (10), the necessary voltage drop across R_O required to calibrate the offset of the output voltage V_{OUTmin} is expressed thus:

$$V_{RO} = 2 \cdot \left(\frac{V_{OUTmin}}{G_{IA} \cdot G_{OUT}} - V_{OSIC} - V_{OSME} \right) \quad (11)$$

On condition, the sensing element offset is low referenced to the sensing element output voltage ($V_{OSME} < 10 V_{OUTME}$), the resistor R_O is calculated with sufficient accuracy as:

$$R_O = \frac{2 \cdot V_{RO}}{I_{IB}} \quad (12)$$

Applying (11) and the condition, that the voltage drop across R_O may only be positive, the maximum compensatable offset is computed thus:

$$V_{OSIC} + V_{OSME} \leq \frac{V_{OUTmin}}{G_{IA} \cdot G_{OUT}} \quad (13)$$

AM417 – Ratiometric instrumentation amplifier with adjustable output stage

If when calculating V_{RO} (Equation 11) a negative value is produced, the resistor R_0 must be placed in the left arm of the bridge (R_0' ; see Figure 3):

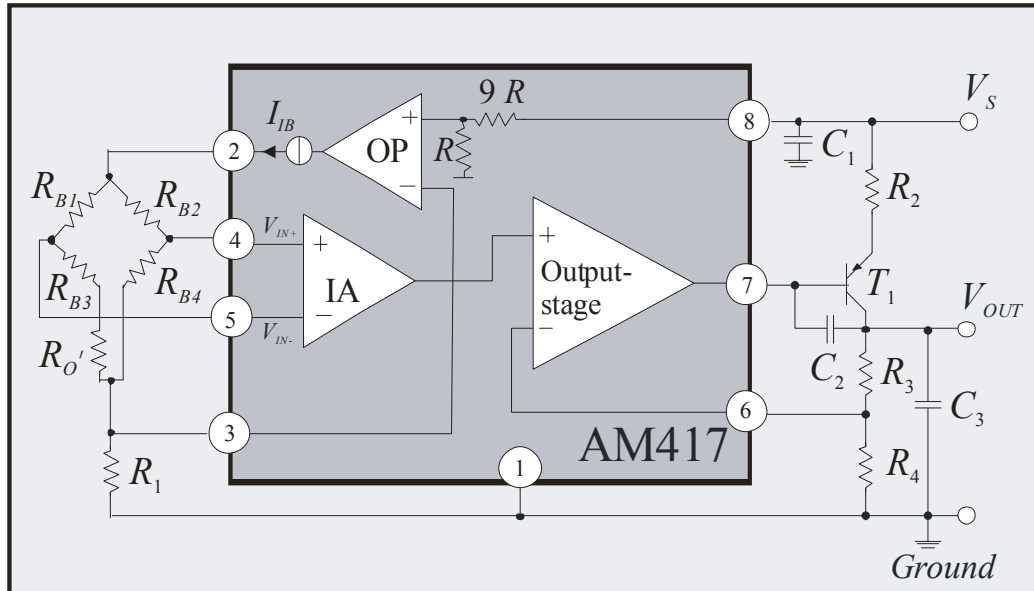

Figure 3: Circuit as in Figure 2 with R_0' (instead R_0) at input pin 5 (IN-)

Doing so changes the effective direction of R_0 and its resistance is now expressed as:

$$R_0' = \frac{2 \cdot (-V_{RO})}{I_{IB}} \quad (12a)$$

AM417 – Ratiometric instrumentation amplifier with adjustable output stage

EXAMPLES

By way of example the equations shall be calculated using typical values for piezoresistive sensing elements [2] in an attempt to illustrate how various sensing elements can be calibrated and compensated with very few external components. The aim of the exercise is to calibrate the output voltage of AM417 to $V_{OUTmin} = 0.5V$ and $V_{OUTmax} = 4.5V$

Example 1: Piezoresistive pressure sensing element in a bridge circuit with a positive offset

- $V_{OUTME} = 160mV$ at $V_{BR} = 5V$
- $V_{CC} = 5V$
- $V_{OUT} = 0.5...4.5V$, $\Rightarrow V_{SPAN} = 4V$, $V_{OUTmin} = 0.5V$
- $V_{OSIC} = -2mV$
- $V_{OSME} = +10mV$ at $V_{BR} = 5V$
- $R_{BR} = 3K\Omega$

The sensing element is to be supplied with constant current as this provides a simple way of compensating the temperature behavior of the span (see: *TEMPERATURE COMPENSATION OF THE OUTPUT SPAN*).

Taking the maximum output voltage at pin 2 (IB) into account the supply current is selected as $I_{IB} = 1mA$ ($R_I = 500\Omega$).

At pin 2 (IB) the voltage is: $V_{IB} = R_{BR} \cdot I_{BR} + V_{VR} = 3k\Omega \cdot 1mA + 0.5V = 3.5V$.

Considering a typical positive temperature coefficient of the sensing element bridge resistor R_{BR} of $TCR = +0.0028/^\circ C$ the maximum voltage at pin 2 (IB) is not overshoot ($V_{IBmax} = 4.8V$ at $V_{CC} = 5V$).

The bridge voltage is: $V_{BR}' = I_{BR} \cdot R_{BR} = 1mA \cdot 3k\Omega = 3V$.

The output voltage of the sensing element given for $V_{BR} = 5V$ must be corrected by the ratio of the bridge voltages:

$$V_{OUTME}' = \frac{160mV \cdot 3V}{5V} = 96mV$$

The offset voltage of the sensing element given for $V_{BR} = 5V$ must be corrected by the ratio of the bridge voltages:

$$V_{OSME}' = \frac{10mV \cdot 3V}{5V} = 6mV$$

Applying Equation 5 the following is accrued:

$$G_{OUT} = \frac{4V}{96mV \cdot 10} = 4.166$$

AM417 – Ratiometric instrumentation amplifier with adjustable output stage

and from Equation 11 we are presented with:

$$V_{RO} = 2 \cdot \left(\frac{0.5V}{10 \cdot 4.166} + 2mV - 6mV \right) = 16mV$$

Referring to Equation 12 the resistance for offset calibration is thus:

$$R_0 = \frac{2 \cdot V_{RO}}{I_{IB}} = 32\Omega$$

If R_0 is set to 32Ω and if we take the offsets of sensing element and IC into consideration, the output signal offset of the overall circuit is set to $V_{OUTmin} = 0.5V$ and the maximum output signal is $V_{OUTmax} = 4.5V$.

Example 2: Piezoresistive pressure sensing element in a bridge circuit with a negative offset

- $V_{OUTME} = 100mV$ at $V_{BR} = 5V$
- $V_{CC} = 5V$
- $V_{OUT} = 0.5...4.5V$, $\Rightarrow V_{SPAN} = 4V$, $V_{OUTmin} = 0.5V$
- $V_{OSIC} = 2mV$
- $V_{OSME} = -10mV$ at $V_{BR} = 5V$

The sensing element is supplied with constant current. Taking the maximum output voltage of the OP into account (see *Example 1*) I_B is again selected as $I_{IB} = 1mA$ ($R_I = 500\Omega$).

The bridge voltage is: $V_{BR}' = I_{BR} \cdot R_{BR} = 1mA \cdot 3k\Omega = 3V$.

The output voltage of the sensing element is corrected by the ratio of the bridge voltages:

$$V_{OUTME}' = \frac{100mV \cdot 3V}{5V} = 60mV$$

The offset voltage of the sensing element is also corrected by the ratio of the bridge voltages:

$$V_{OSME}' = \frac{-10mV \cdot 3V}{5V} = -6mV$$

Applying Equation 5 the following is accrued:

$$G_{OUT} = \frac{4V}{60mV \cdot 10} = 6.67$$

AM417 – Ratiometric instrumentation amplifier with adjustable output stage

and from Equation 11 we are presented with:

$$V_{RO} = 2 \cdot \left(\frac{0.5V}{10 \cdot 6.67} - 2mV + 6mV \right) = 23mV$$

Referring to Equation 12 the resistance for offset calibration is thus:

$$R_0 = \frac{2 \cdot V_{RO}}{I_{IB}} = 46\Omega$$

If R_0 is set to 46Ω and if we take the offsets of sensing element and IC into consideration, the output signal offset of the overall circuit is set to $V_{OUTmin} = 0.5V$ and the maximum output signal is $V_{OUTmax} = 4.5V$.

Example 3: Piezoresistive pressure sensing element in a bridge circuit with a high positive offset

- $V_{OUTME} = 100mV$ at $V_{BR} = 5V$
- $V_{CC} = 5V$
- $V_{OUT} = 0.5...4.5V$, $\Rightarrow V_{SPAN} = 4V$, $V_{OUTmin} = 0.5V$
- $V_{OSIC} = 2mV$
- $V_{OSME} = 10mV$ at $V_{BR} = 5V$
- $R_{BR} = 3K\Omega$

The sensing element is supplied with constant current. Taking the maximum output voltage of the OP into account I_B is again selected as $I_{IB} = 1mA$ ($R_I = 500\Omega$).

The bridge voltage is: $V_{BR}' = I_{BR} \cdot R_{BR} = 1mA \cdot 3k\Omega = 3V$.

The output voltage of the sensing element is corrected by the ratio of the bridge voltages:

$$V_{OUTME}' = \frac{100mV \cdot 3V}{5V} = 60mV$$

The offset voltage of the sensing element is also corrected by the ratio of the bridge voltages:

$$V_{OSME}' = \frac{10mV \cdot 3V}{5V} = 6mV$$

Applying Equation 5 the following is accrued:

$$G_{OUT} = \frac{4V}{60mV \cdot 10} = 6.67$$

AM417 – Ratiometric instrumentation amplifier with adjustable output stage

and from Equation 11 we are presented with:

$$V_{RO} = 2 \cdot \left(\frac{0.5V}{10 \cdot 6.67} - 2mV - 6mV \right) = -6.5mV$$

Referring to Equation 12a the resistance for offset calibration is thus:

$$R_0' = \frac{2 \cdot (-V_{RO})}{I_{IB}} = 13\Omega$$

If R_0' (resistor on the left) is set to 13Ω and if we take the offsets of sensing element and IC into consideration, the output signal offset of the overall circuit is set to $V_{OUTmin} = 0.5V$ and the maximum output signal is $V_{OUTmax} = 4.5V$.

TEMPERATURE COMPENSATION OF THE OUTPUT SPAN

Supplying a piezoresistive sensing element with constant current makes compensation of the temperature of the span a relatively simple affair. With a constant current supply the negative temperature coefficient of sensor sensitivity S can be compensated by the positive temperature coefficient of bridge resistor R_{BR} .

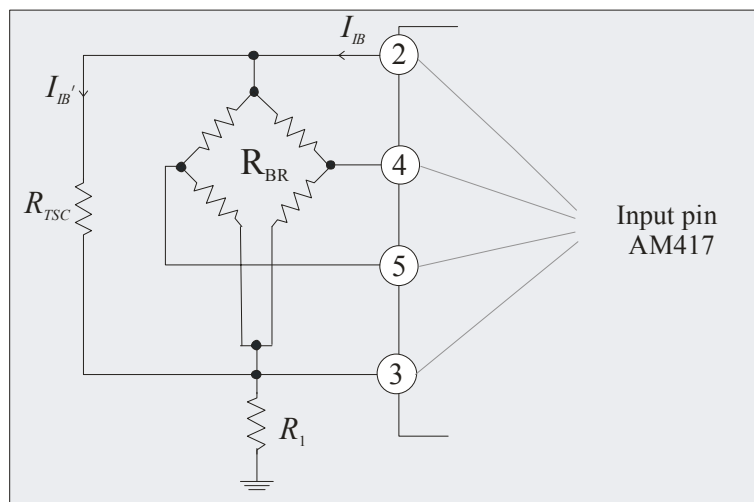

Figure 4: Bridge array for the compensation of TC with
 R_{BR} = bridge resistor

AM417 – Ratiometric instrumentation amplifier with adjustable output stage

The output signal of a piezoresistive sensing element is accrued from:

$$V_{OUTME} = S \cdot P \cdot V_{BR} = S \cdot P \cdot I_{IB} \cdot R_{BR} \quad (14)$$

S is the sensor sensitivity of the sensing element and P is the applied pressure. Sensor sensitivity S and bridge resistor R_{BR} are the dominant temperature-dependent variables in Equation 14. The following applies:

$$S = S_0 \cdot (1 + TCS \cdot (T - T_0)) \quad (15)$$

$$R_{BR} = R_{BR0} \cdot (1 + TCR \cdot (T - T_0)) \quad (16)$$

S_0 is the basic value of the sensitivity and R_{BR0} the basic value of the bridge resistance at T_0 (usually room temperature). T is the actual temperature.

TCS and TCR are the linear temperature coefficients of sensitivity and bridge resistance. Typical values are:

$$TCS = -0.0019/^\circ\text{C} \text{ and } TCR = +0.0028/^\circ\text{C} \text{ [3].}$$

Good temperature compensation of sensing element output signal V_{OUTME} would be automatically achieved if both temperature coefficients had the same value. If both are different, however, an attempt is made to equalize them. This is done by adding an additional compensatory TCS resistor R_{TCS} which is inserted parallel to the sensing element (see *Figure 4*). The TCR value of the entire system is thus amended so that it is the same as TCS of the sensing element.

In the temperature compensation of the sensing element output signal described above the following applies to the compensatory TCS resistor:

$$R_{TCS} = R_{BR} \cdot \frac{-TCS}{TCR + TCS} \quad (17)$$

As part of the set bridge supply current I_{IB}' flows through the shunt resistor R_{TCS} the circuit output signal is reduced after TCS compensation according to the following equation:

$$\frac{I_{IB}'}{I_{IB}} = \frac{R_{TCS}}{(R_{TCS} + R_{BR})} \quad (18)$$

In order to reinstate the original output signal of the circuitry the circuit gain must be increased by the reciprocal ratio:

$$TCSFactor = \frac{I_{IB}}{I_{IB}'} = \frac{(R_{TCS} + R_{BR})}{R_{TCS}} \quad (19)$$

AM417 – Ratiometric instrumentation amplifier with adjustable output stage

In order to achieve a maximum a sensing element output signal it is best to increase set bridge supply current I_{IB} by the *TCS Factor*. Gain G_{OUT} can also be increased by the same factor if, for example, maximum bridge current $I_{IBmax} = 1.25\text{mA}$ or if the maximum voltage at pin 2 (IB) is overshoot during an increase.

EXAMPLE

Example 4: TCS compensation of a piezoresistive pressure sensing element [2]

- $TCS = -0.0019/^\circ\text{C}$
- $V_{CC} = 5\text{V}$
- $R_{BR} = 3\text{K}\Omega$
- $TCR = +0.0028/^\circ\text{C}$
- *Temperature range: $-20^\circ\text{C} - 80^\circ\text{C}$*

Bridge supply current I_{IB} is selected according to the following. Assuming that the maximum operating temperature of the circuit is 80°C , the maximum bridge resistance is calculated using Equation (16):

$$R_{RB\max} = 3\text{k}\Omega \cdot (1 + 0,0028/^\circ\text{C} \cdot (80^\circ\text{C} - 25^\circ\text{C})) = 3,46\text{k}\Omega$$

With a bridge current of $I_{IB} = 0.8\text{mA}$, at 80°C and $V_{CC} = 5\text{V}$, pin 2 (IB) has a potential of:

$$V_{IB} = 3.46\text{k}\Omega \cdot 0.8\text{mA} + 0.5\text{V} = 3.27\text{V}$$

Applying Equation (17):

$$R_{TCS} = 6.33\text{K}\Omega$$

Using Equation (19) the following is calculated for T_0 :

$$TCSFactor = 1.47$$

If bridge current I_{IB} is now increased by a factor of *TCSFactor*, the result is a new amended bridge current of:

$$I_{IBnew} = 1.18\text{mA}$$

The original output signal of the sensing element is thus reinstated following TCS compensation.

Output stage gain G_{OUT} could also be increased by a factor of *TCSFactor* by adjusting resistors R_3 and R_4 according to Equation (2).

AM417 – Ratiometric instrumentation amplifier with adjustable output stage

BLOCK DIAGRAM AND PINOUT

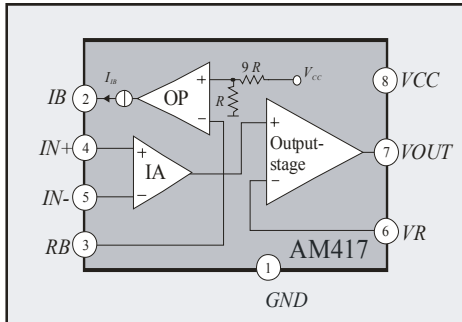

Figure 5: Circuit diagram of AM417

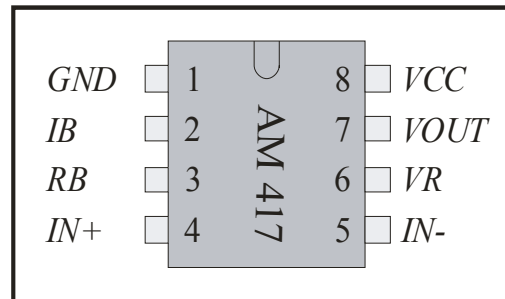

Figure 6: AM417 Pin out

PIN	NAME	FUNCTION
1	GND	IC Ground
2	IB	Current Source Output
3	RB	Current Source Set
4	IN+	Positive IA Input
5	IN-	Negative IA Input
6	VR	Gain Set
7	VOUT	Voltage Output
8	VCC	Supply Voltage

Table 3: Pin out

DELIVERY

AM417 is available as:

- An SOP08
- Dice on 5" blue foil

AM417 – Ratiometric instrumentation amplifier with adjustable output stage

EXAMPLE APPLICATIONS

- Interface IC for sensing elements in a resistor bridge circuit (e.g. piezoresistive pressure sensing elements) with electronic compensation of errors via an external microcontroller. In this application AM417 is used as a preamplifier to set the operating point.

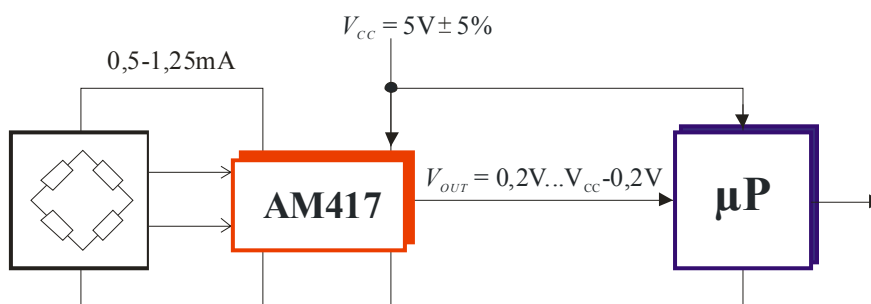

Figure 7: Application for sensing elements with an external microcontroller or ADC

- Signal conditioning IC with an external, analog compensation network, in which the offset can be adjusted using additional resistors on the sensing element and the gain using AM417.

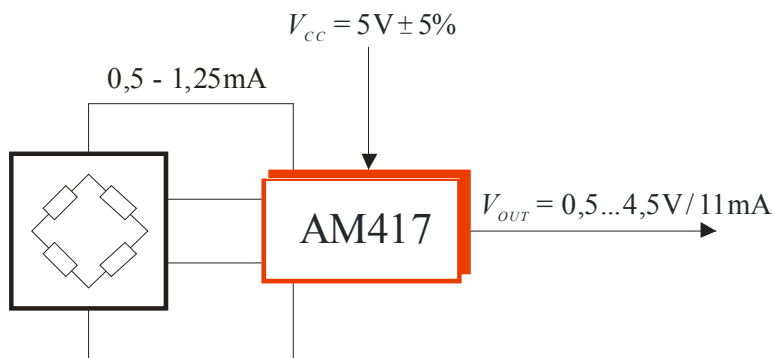

Figure 8: Application as a signal conditioning IC with an external compensation network

How to protect the output of the AM467 against reverse polarity see [3]

AM417 – Ratiometric instrumentation amplifier with adjustable output stage

FURTHER READING

- [1] The Analog Microelectronics GmbH website: <http://www.analogmicro.de/>
- [2] On the AMSYS GmbH website: <http://www.amsys.info/products/ms54xx.htm>
- [3] Reverse polarity protection for a ratiometric application using AM417:
<http://www.analogmicro.de/products/info/english/analogmicro.de.an1019.pdf>

Analog Microelectronics reserves the right to make amendments to any dimensions, technical data or other information herein without further notice.



Analog Microelectronics GmbH
An der Fahrt 13, D – 55124 Mainz

Phone: +49 (0)6131/91 073-0
Fax: +49 (0)6131/91 073-30
Internet: <http://www.analogmicro.de>
Email: info@analogmicro.de

July 2008 – Rev 3.1- Page 18/18