

Industrial V/I Converter and Protector IC AM462

PRINCIPLE FUNCTION

Conversion of input voltage referenced to ground to output current
Integrated protection for IC and external components
Integrated, adjustable current/voltage sources for external components

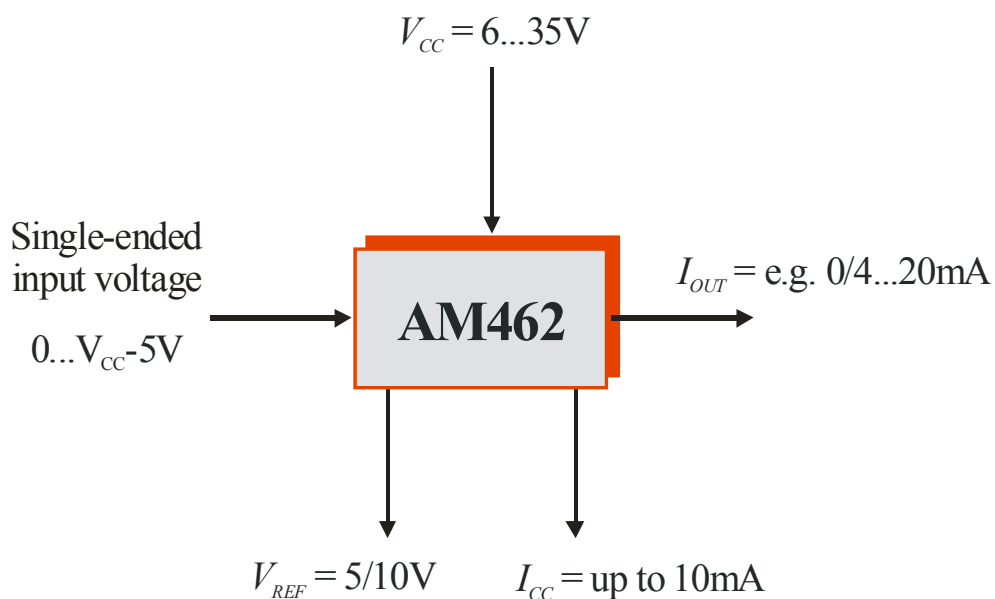

TYPICAL APPLICATIONS

- Adjustable voltage-to-current (V/I) converter
- Adjustable voltage and current source (supply unit)
- Voltage regulator with additional functions
- Industrial protector and output IC for microprocessors (the Frame ASIC concept [1])
- Peripheral processor IC
- For examples of typical applications see *Example Applications*

**analog microelectronics**
integrated circuits

Analog Microelectronics GmbH
An der Fahrt 13, D – 55124 Mainz

Phone: +49 (0)6131/91 073-0

Fax: +49 (0)6131/91 073-30

Internet:

<http://www.analogmicro.de>

Email: info@analogmicro.de

Oktober 2007 – Rev.2.5 -Page 1/20

Industrial V/I Converter and Protector IC AM462

CONTENTS

CONTENTS	2
FEATURES	3
GENERAL DESCRIPTION	3
BLOCK DIAGRAM	3
ELECTRICAL SPECIFICATIONS	4
BOUNDARY CONDITIONS	6
DETAILED DESCRIPTION OF FUNCTIONS	6
INITIAL OPERATION OF AM462	8
General information on 2- and 3-wire applications and the use of current	8
Setting the output current range	8
Selecting the supply voltage	9
Using OP2 as a current source	10
Using OP2 as a voltage reference	11
POINTS TO NOTE: INITIAL OPERATION OF AM462	12
APPLICATIONS	12
Typical 3-wire application with an input signal referenced to ground	12
Typical 2-wire application with an input signal referenced to ground	13
Application for an input signal with an offset	15
BLOCK DIAGRAM AND PINOUT	17
EXAMPLE APPLICATIONS	18
DELIVERY	20
PACKAGE DIMENSIONS	20
FURTHER READING	20



Analog Microelectronics GmbH
An der Fahrt 13, D – 55124 Mainz

Phone: +49 (0)6131/91 073-0
Fax: +49 (0)6131/91 073-30
Internet:
<http://www.analogmicro.de>
Email: info@analogmicro.de

Oktober 2007 – Rev.2.5 -Page 2/20

Industrial V/I Converter and Protector IC AM462

FEATURES

- Supply voltage: 6...35V
- Wide working temperature range: $-40^{\circ}\text{C} \dots +85^{\circ}\text{C}$
- Adjustable integrated reference voltage source: 4.5 to 10V
- Additional voltage/current source
- Adjustable amplification
- Adjustable offset
- Industrial current output (e.g. 0/4...20mA)
- Protection against reverse polarity
- Short-circuit protection
- Output current limitation
- Low-cost device: replaces a number of discrete elements
- 2- and 3-wire operation
- Individually configurable function modules
- RoHS compliant

GENERAL DESCRIPTION

AM462 is a universal V/I converter and amplifier IC with a number of additional functions. The IC basically consists of an amplifier, whose gain can be set externally, and an output stage which can convert voltage signals referenced to ground to industrial current signals. An additional reference voltage source for the supply of external components is also included in the device. A further operational amplifier can be connected up as a current source, voltage reference or comparator.

One of the main features of the IC is its integrated protective circuitry. The device is protected against reverse polarity and has a built-in output current limit. Converter IC AM462 enables industrial current loop signals (e.g. of 0/4–20mA) to be produced relatively easily.

Using the Frame ASIC concept [1] the IC can be connected up to a processor for signal correction.

BLOCK DIAGRAM

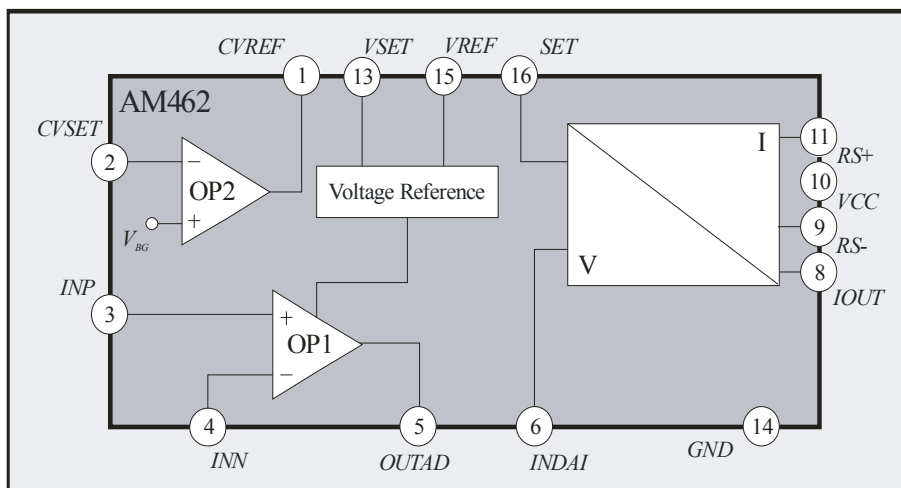

Figure 1: Block diagram of AM462 (individually configurable function modules)

Industrial V/I Converter and Protector IC

AM462

ELECTRICAL SPECIFICATIONS

$T_{amb} = 25^{\circ}\text{C}$, $V_{CC} = 24\text{V}$, $V_{REF} = 5\text{V}$, $I_{REF} = 1\text{mA}$ (unless otherwise stated); currents flowing into the IC are negative.

Parameter	Symbol	Conditions	Min.	Typ.	Max.	Unit
Supply Voltage Range	V_{CC}		6		35	V
Quiescent Current	I_{CC}	$T_{amb} = -40\dots+85^{\circ}\text{C}$, $I_{REF} = 0\text{mA}$			1.5	mA
Temperature Specifications						
Operating	T_{amb}		-40		85	$^{\circ}\text{C}$
Storage	T_{st}		-55		125	$^{\circ}\text{C}$
Junction	T_J				150	$^{\circ}\text{C}$
Thermal Resistance	Θ_{ja}	DIL16 plastic package		70		$^{\circ}\text{C}/\text{W}$
	Θ_{ja}	SO16 narrow plastic package		140		$^{\circ}\text{C}/\text{W}$
Voltage Reference						
Voltage	V_{REF}	V_{SET} not connected	4.75	5.00	5.25	V
	V_{REF10}	$V_{SET} = GND$, $V_{CC} \geq 11\text{V}$	9.5	10.0	10.5	V
Trim Range	V_{REFADJ}		4.5		V_{REF10}	V
Current	I_{REF}^*		0		10.0	mA
V_{REF} vs. Temperature	dV_{REF}/dT	$T_{amb} = -40\dots+85^{\circ}\text{C}$		± 90	± 140	ppm/ $^{\circ}\text{C}$
Line Regulation	dV_{REF}/dV	$V_{CC} = 6\text{V}\dots 35\text{V}$		30	80	ppm/V
	dV_{REF}/dV	$V_{CC} = 6\text{V}\dots 35\text{V}$, $I_{REF} \approx 5\text{mA}$		60	150	ppm/V
Load Regulation	dV_{REF}/dI			0.05	0.10	%/mA
	dV_{REF}/dI	$I_{REF} \approx 5\text{mA}$		0.06	0.15	%/mA
Load Capacitance	C_L		1.9	2.2	5.0	μF
Current/Voltage Source OP2						
Internal Reference	V_{BG}		1.20	1.27	1.35	V
V_{BG} vs. Temperature	dV_{BG}/dT	$T_{amb} = -40\dots+85^{\circ}\text{C}$		± 60	± 140	ppm/ $^{\circ}\text{C}$
Current Source: $I_{CV} = V_{BG}/R_{SET}$, from Figure 5						
Adjustable Current Range	I_{CV}^*		0		10	mA
Output Voltage	V_{CV}	$V_{CC} < 19\text{V}$	V_{BG}		$V_{CC} - 4$	V
	V_{CV}	$V_{CC} \geq 19\text{V}$	V_{BG}		15	V
Voltage Source: $V_{CV} = V_{BG} (1 + R_7 / R_6)$, from Figure 6						
Adjustable Voltage Range	V_{CV}	$V_{CC} < 19\text{V}$	0.4		$V_{CC} - 4$	V
	V_{CV}	$V_{CC} \geq 19\text{V}$	0.4		15	V
Output Current	I_{CV}^*	Source			10	mA
	I_{CV}	Sink			-100	μA
Load Capacitance	C_L	Source mode	0	1	10	nF
Operational Amplifier Gain Stage (OP1)						
Adjustable Gain	G_{GAIN}		1			
Input Range	I_R	$V_{CC} < 10\text{V}$	0		$V_{CC} - 5$	V
	I_R	$V_{CC} \geq 10\text{V}$	0		5	V
Power Supply Rejection Ratio	$PSRR$		80	90		dB
Offset Voltage	V_{OS}			± 0.5	± 2	mV



Analog Microelectronics GmbH
An der Fahrt 13, D – 55124 Mainz

Phone: +49 (0)6131/91 073-0

Fax: +49 (0)6131/91 073-30

Internet:

<http://www.analogmicro.de>

Email: info@analogmicro.de

Oktober 2007 – Rev.2.5 -Page 4/20

Industrial V/I Converter and Protector IC

AM462

Parameter	Symbol	Conditions	Min.	Typ.	Max.	Unit
Operational Amplifier Gain Stage (OP1) (cont.)						
V_{OS} vs. Temperature	dV_{OS}/dT			±3	±7	μV/°C
Input Bias Current	I_B			10	25	nA
I_B vs. Temperature	dI_B/dT			7	20	pA/°C
Output Voltage Limitation	V_{LIM}			V_{REF}		V
Output Voltage Range	V_{OUTAD}	$V_{CC} < 10V$	0		$V_{CC} - 5$	V
	V_{OUTAD}	$V_{CC} \geq 10V$	0		V_{REF}	V
Load Capacitance	C_L				250	pF
V/I Converter						
Internal Gain	G_{VI}		0,12	0.125	0,13	
Trim Range		Adjustable by R_0	0.75	1.00	1.25	
Voltage Range at R_0 FS	V_{R0FS}		350		750	mV
Offset Voltage	V_{OS}	Forward Current Gain of $T_1 \beta_F \geq 100$		±2	±4	mV
V_{OS} vs. Temperature	dV_{OS}/dT	Forward Current Gain of $T_1 \beta_F \geq 100$		±7	±14	μV/°C
Input Resistance	R_{IN}		120	160		kΩ
R_{IN} vs. Temperature	dR_{IN}/dT		0.2	0.3		kΩ/°C
Output Offset Current	I_{OUTOS}	3-wire operation		-25	-35	μA
I_{OUTOS} vs. Temperature	dI_{OUTOS}/dT	3-wire operation		16	26	nA/°C
Output Offset Current	I_{OUTOS}	2-wire operation		9.5	14	μA
I_{OUTOS} vs. Temperature	dI_{OUTOS}/dT	2-wire operation		6	8	nA/°C
Output Control Current	I_{OUTC}	2-wire operation, $V_{RO}/100mV$		6	8	μA
I_{OUTC} vs. Temperature	dI_{OUTC}/dT	2-wire operation		-10	-15	nA/°C
Output Voltage Range	V_{OUT}	$V_{OUT} = R_L I_{OUT}, V_{CC} < 18V$	0		$V_{CC} - 6$	V
	V_{OUT}	$V_{OUT} = R_L I_{OUT}, V_{CC} \geq 18V$	0		12	V
Output Current Range FS	I_{OUTFS}	$I_{OUT} = V_{RO}/R_0, 3\text{-wire operation}$		20		mA
Output Resistance	R_{OUT}		0.5	1.0		MΩ
Load Capacitance	C_L		0		500	nF
SET Stage						
Internal Gain	G_{SET}			0.5		
Input Voltage	V_{SET}		0		1.15	V
Offset Voltage	V_{OS}			±0.5	±1.5	mV
V_{OS} vs. Temperature	dV_{OS}/dT			±1.6	±5	μV/°C
Input Bias Current	I_B			8	20	nA
I_B vs. Temperature	dI_B/dT			7	18	pA/°C
Protection Functions						
Voltage Limitation at R_0	V_{LIMR0}	$V_{INDAI} = 0, V_{RO} = G_{SET} V_{SET}$	580	635	690	mV
Protection against reverse polarity		Ground vs. V_S vs. V_{OUT}			35	V
		Ground vs. V_S vs. I_{OUT}			35	V
Current in the event of reverse polarity		Ground = 35V, $V_S = I_{OUT} = 0$		4.5		mA
System Parameters						
Nonlinearity		Ideal input		0.05	0.15	%FS

* In 2-wire operation a maximum current of $I_{OUTmin} - I_{CC}$ is valid



Analog Microelectronics GmbH
An der Fahrt 13, D – 55124 Mainz

Phone: +49 (0)6131/91 073-0

Fax: +49 (0)6131/91 073-30

Internet:

<http://www.analogmicro.de>

Email: info@analogmicro.de

Oktober 2007 – Rev.2.5 -Page 5/20

Industrial V/I Converter and Protector IC

AM462

BOUNDARY CONDITIONS

Parameter	Symbol	Conditions	Min.	Typ.	Max.	Unit
Sense Resistor	R_0	$I_{OUTFS} = 20\text{mA}$	17	27	38	□
	R	$c = 20\text{mA}/I_{OUTFS}$	$c \cdot 17$	$c \cdot 27$	$c \cdot 38$	□
Stabilization Resistor	R_5	$I_{OUTFS} = 20\text{mA}$	35	40	45	□
	R_5	$c = 20\text{mA}/I_{OUTFS}$	$c \cdot 35$	$c \cdot 40$	$c \cdot 45$	□
Load Resistance	R_L	Limitation only for 3-wire operation	0		600	□
Sum Gain Resistors	$R_1 + R_2$		20		200	k□
Sum Offset Resistors	$R_3 + R_4$		20		200	k□
V_{REF} Capacitance	C_1	Ceramic	1.9	2.2	5.0	μF
Output Capacitance	C_2	Only for 2-wire operation	90	100	250	nF
D_1 Breakdown Voltage	V_{BR}		35	50		V
T_1 Forward Current Gain	β_F	BCX54/55/56, for example	50	150		

DETAILED DESCRIPTION OF FUNCTIONS

AM462 is a modular, universal V/I converter and protector IC which has been specially developed for the conditioning of voltage signals referenced to ground. It is designed for both 2- and 3-wire operation in industrial applications (cf. application in Figure 8). AM462's various functions are depicted in the block diagram (Figure 2) which also illustrates how few external components are required for the operation of this particular device.

AM462 consists of several modular function blocks (operational amplifiers, voltage-to-current converters and references) which, depending on external configurations, can either be switched to one another or operated separately (see the basic circuitry in Figure 2):

1. *Operational amplifier stage* OP1 enables a positive voltage signal to be amplified. OP1 gain G_{GAIN} can be set via external resistors R_1 and R_2 . Protective circuitry against overvoltage is integrated into the chip, limiting the voltage to the set value of the reference voltage. Output voltage V_{OUTAD} at pin $OUTAD$ is calculated as:

$$V_{OUTAD} = V_{INP} \cdot G_{GAIN} \text{ with } G_{GAIN} = 1 + \frac{R_1}{R_2} \quad (1)$$

where V_{INP} is the voltage at OP1's input pin 6 (INP).

2. The internal voltage-to-current converter (V/I converter) provides a voltage-controlled current signal at IC output I_{OUT} (pin 8) which activates an external transistor T_1 ; this in turn supplies the actual output current I_{OUT} . To reduce power dissipation the transistor is an external component and protected against reverse polarity by an additional diode D_1 . Via pin SET an offset current I_{SET} can be set at output I_{OUT} (with the help of the internal voltage reference and an external voltage divider as shown in Figure 2, for example). External resistor R_0 permits the output current to be finely adjusted with parallel operation of current and the voltage output. For the output current provided by T_1 the following ratio applies:



Analog Microelectronics GmbH
An der Fahrt 13, D – 55124 Mainz

Phone: +49 (0)6131/91 073-0

Fax: +49 (0)6131/91 073-30

Internet:

<http://www.analogmicro.de>

Email: info@analogmicro.de

Oktober 2007 – Rev.2.5 -Page 6/20

Industrial V/I Converter and Protector IC AM462

$$I_{OUT} = \frac{V_{INDAI} \cdot G_{IV}}{R_0} + I_{SET} = \frac{V_{INDAI}}{8R_0} + I_{SET} \quad \text{with } I_{SET} = \frac{V_{SET}}{2R_0} \quad (2)$$

with V_{INDAI} the voltage at pin 6 ($INDAI$) and V_{SET} the voltage at pin 16 (SET)¹.

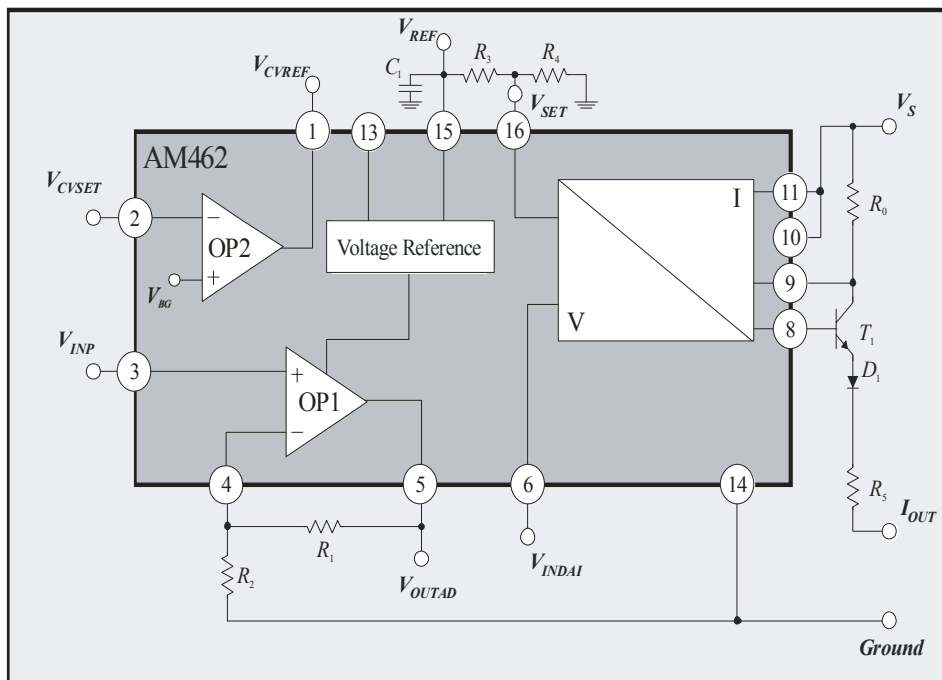

Figure 2: Block diagram of AM462 (3-wire circuit for current output). Pin 1 and 2 have to be connected.

- The AM462 *reference voltage source* enables voltage to be supplied to external components (such as sensors, microprocessors, etc.). The reference voltage value V_{REF} can be set via pin 13 V_{SET} . If pin V_{SET} is not connected, $V_{REF} = 5V$; if V_{SET} is switched to ground, $V_{REF} = 10V$. Values between the above can be set if two external resistors are used (inserted between pin V_{REF} and pin V_{SET} and between pin V_{SET} and GND ; see Figure 2).

External (ceramic) capacitor C_1 at pin V_{REF} stabilizes the reference voltage. It **must** be connected even if the voltage reference is not in use.

- The additional *operational amplifier stage* OP2 can be used as a current or voltage source to supply external components. OP2's positive input is connected internally to voltage V_{BG} so that the output current or output voltage can be set across a wide range using external resistors.

¹ The construction of the V/I converter is such that output current I_{OUT} is largely independent of the current amplification β_F of external transistor T_1 . Production-specific variations in the current amplification of the transistors used are compensated for internally by the V/I converter.

Industrial V/I Converter and Protector IC AM462

INITIAL OPERATION OF AM462

General information on 2- and 3-wire applications and the use of current

In 3-wire operation (cf. Figure 3 right and Figure 7) the ground of the IC (pin *GND*) is connected up to the external mass of the system *Ground*. The system's supply voltage V_S is connected to pin *VCC* and pin *VCC* to pin *RS+*.

In 2-wire operation (cf. Figure 3 left and Figure 7) system supply voltage V_S is connected to pin *RS+* and pin *VCC* to *RS-*. The ground of the IC (pin *GND*) is connected to the node between resistor R_S and load resistor R_L (current output I_{OUT}). IC ground (*GND*) is **not** the same as system ground (*Ground*)!! The output signal is picked up via load resistor R_L which connects current output I_{OUT} to the system ground.

In 2-wire operation the IC ground is "virtual" (floating), as with a constant load resistance the supply voltage of the device V_{CC} changes according to the current. As a rule, the following equation applies to 2-wire operation:

$$V_{CC} = V_S - I_{OUT}(V_{IN}) R_L \quad (3)$$

The reason for this is that in 2-wire operation the IC is connected in series to the actual load resistor R_L . This is illustrated in Figure 3.

In 3-wire operation $V_{CC} = V_S$, as the IC ground is connected to the ground of the system.

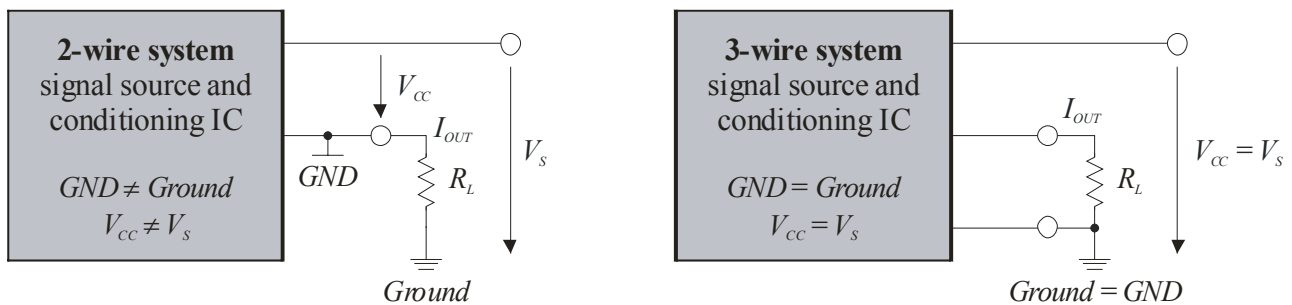

Figure 3: The difference between 2- and 3-wire operation

Setting the output current range

When using amplification stage OP1 together with the V/I converter for voltage-to-current conversion the offset of the output current should first be compensated for by suitable selection of resistors R_3 and R_4 . To this end the OP1 input must be connected to ground ($V_{INP} = 0$). With the short circuit at the input and by connecting up V/I converter pin *VSET* as shown in Figure 2 the values of the output current according to Equation 2 are as follows:

Industrial V/I Converter and Protector IC AM462

$$I_{OUT}(V_{INDAI} = 0) = I_{SET} = \frac{V_{REF}}{2R_0} \cdot \frac{R_4}{R_3 + R_4} \quad (4)$$

and thus for the ratio of the resistors R_3/R_4 :

$$\frac{R_3}{R_4} = \frac{V_{REF}}{2R_0 I_{SET}} - 1 \quad (5)$$

The output current range is set in conjunction with the selected external resistors R_1 and R_2 (or fine adjustment with R_0). Using Equations 1 and 2 the following is calculated for output current I_{OUT} :

$$I_{OUT} = V_{INP} \frac{G_{GAIN}}{8R_0} + I_{SET} \quad \text{with} \quad G_{GAIN} = 1 + \frac{R_1}{R_2} \quad (6)$$

Selecting the supply voltage

System supply voltage V_S needed to operate AM462 is dependent on the selected mode of operation.

When using current output pin I_{OUT} (in conjunction with the external transistor) the value of V_S is dependent on that of the relevant load resistor R_L (max. 600Ω) used by the application. The minimum system supply voltage V_S is then:

$$V_S \geq I_{OUTmax} R_L + V_{CCmin} \quad (7)$$

Here, I_{OUTmax} stands for the maximum output current and V_{CCmin} for the minimum IC supply voltage which is dependent on the selected reference voltage:

$$V_{CCmin} \geq V_{REF} + 1V \quad (8)$$

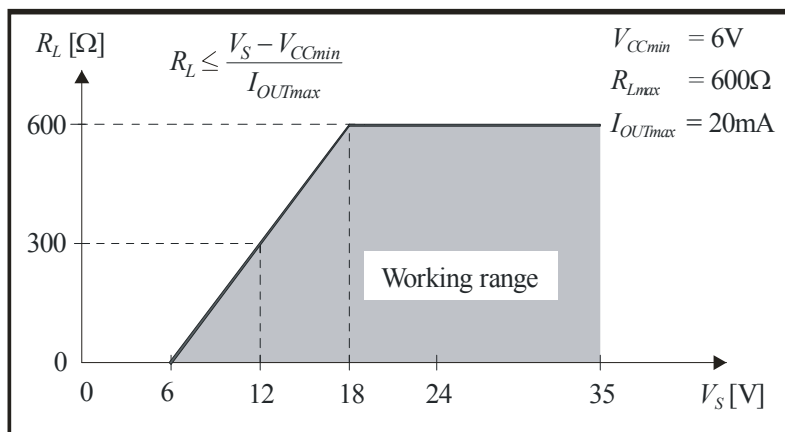

Figure 4: Working range in conjunction with the load resistor

Industrial V/I Converter and Protector IC AM462

The working range resulting from Equation **Fehler! Verweisquelle konnte nicht gefunden werden.** is described in Figure 4. Example calculations and typical values for the external components can be found in the example applications from page 13 onwards.

Using OP2 as a current source

The additional operational amplifier OP2 can easily be connected up as a constant current source. Using the circuit in Figure 5 the following applies:

Example : OP2 as current source

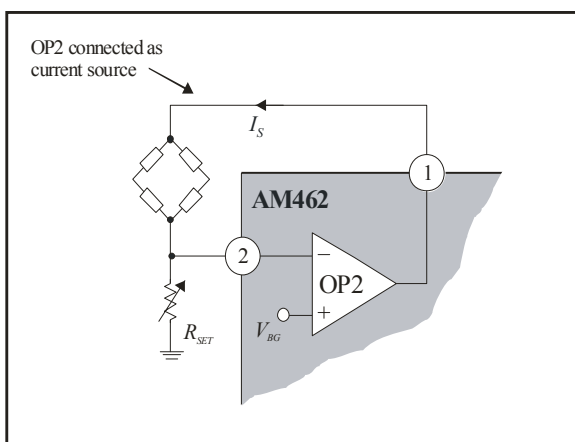

Figure 5: Using OP2 as a constant current source

$$I_S = \frac{V_{BG}}{R_{SET}} = \frac{1.27\text{ V}}{R_{SET}} \quad (9)$$

The bridge symbol represents the component to be supplied with current (e.g. a piezoresistive sensing element or temperature sensor).

A supply current of $I_S = 1\text{ mA}$ is to be set. Using Equation **Fehler! Verweisquelle konnte nicht gefunden werden.** the following value is calculated for external resistor R_{SET} , which in turn stipulates the size of the current:

$$R_{SET} = \frac{V_{BG}}{I_S} = \frac{1.27\text{ V}}{1\text{ mA}} = 1.27\text{ k}\Omega$$

Industrial V/I Converter and Protector IC AM462

Using OP2 as a voltage reference

In addition to the integrated voltage reference OP2 can also be used to supply voltage to external components, such as A/D converters and microprocessors, for example. Lower voltages can be generated (e.g. 3.3V) which with the increasing miniaturization of devices and need for ever lower levels of power dissipation in digital components is today of growing importance.

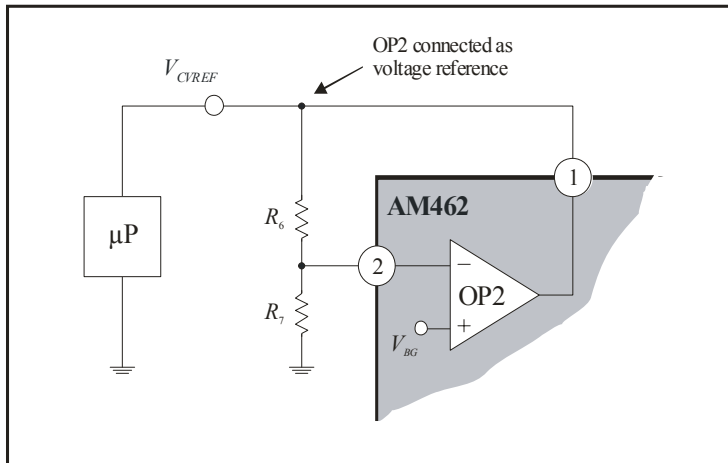

Figure 6: Using OP2 as a voltage reference

The additional operational amplifier OP2 can easily be connected up as a voltage reference. Using the circuit in *Figure 6* the following applies:

$$V_{CVREF} = V_{BG} \left(1 + \frac{R_6}{R_7} \right) = 1.27 \text{ V} \left(1 + \frac{R_6}{R_7} \right) \quad (10)$$

Example : OP2 as voltage reference

A voltage of $V_{CVREF} = 3.3\text{V}$ is to be set. Using Equation (10) the following ratio is calculated for external resistors R_6 and R_7 :

$$\frac{R_6}{R_7} = \frac{V_{CVREF}}{V_{BG}} - 1 \approx 2,6 - 1 = 1,6$$

The following example values are produced for the resistors:

$$R_7 = 10\text{k}\Omega \quad R_6 = 16\text{k}\Omega$$

Industrial V/I Converter and Protector IC AM462

POINTS TO NOTE: INITIAL OPERATION OF AM462

1. When operating AM462 it is imperative that external capacitor C_1 is **always** connected (cf. **Figure 2**). Care must be taken that the value of the capacitance does not lie beyond its given range, even across the range of temperature (see *Boundary Conditions* on page 7). In 2-wire operation ceramic capacitor C_2 must also be used (cf. Figure 8).
2. In a 2-wire setup the power consumption of the overall system (AM462 plus all external components, including the configuration resistors) **must not exceed** the sum of I_{OUTmin} (usually 4mA).
3. All AM462 function blocks not required by the application must be connected to a defined (and allowed) potential.
4. A load resistance of 600Ω **maximum** is permitted for the current output.
5. The values of external resistors R_0, R_1, R_2, R_3, R_4 and R_5 must be selected within the permissible range given in the boundary conditions on page 7.

APPLICATIONS

Typical 3-wire application with an input signal referenced to ground

Figure 7 shows a 3-wire application in which AM462 amplifies and converts a positive voltage signal referenced to ground. The unused blocks (e.g. OP2) have been set to defined operating points in the application. Alternatively, these function groups can also be used here (e.g. to supply external components).

For output current I_{OUT} the following applies according to Equations (1) and (2):

$$I_{OUT} = V_{INP} \cdot \frac{G_{GAIN}}{8R_0} + I_{SET} \quad \text{with} \quad G_{GAIN} = 1 + \frac{R_1}{R_2}$$

Example: 0...20mA Voltage-To-Current Converter

To convert a signal of $V_{INP} = 0...1V$ at the OP1 input the external components are to be dimensioned in such a way that the output current has a range of 0...20mA (i.e. $I_{SET} = 0 \Rightarrow SET = GND$). With $R_0 = 27\Omega$:

$$I_{OUT} = V_{INP} \cdot \frac{G_{GAIN}}{8R_0} + I_{SET} = V_{INP} \cdot \frac{G_{GAIN}}{8R_0}$$

The following then applies to the gain:



Analog Microelectronics GmbH
An der Fahrt 13, D – 55124 Mainz

Phone: +49 (0)6131/91 073-0

Fax: +49 (0)6131/91 073-30

Internet:

<http://www.analogmicro.de>

Email: info@analogmicro.de

Oktober 2007 – Rev.2.5 -Page 12/20

Industrial V/I Converter and Protector IC AM462

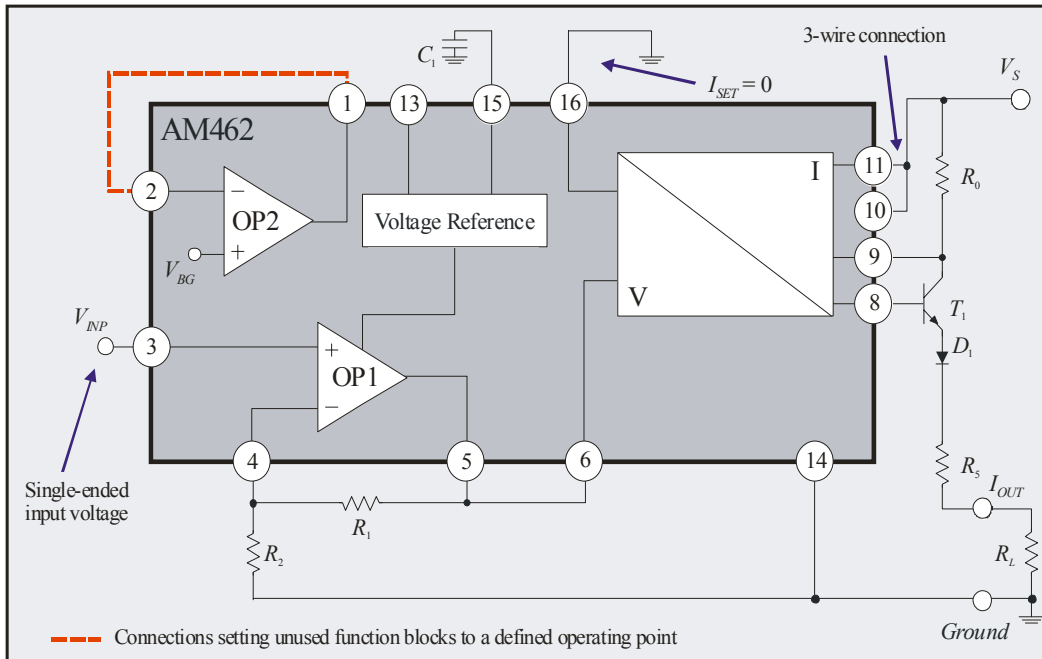

Figure 7: Typical application for input signals referenced to ground

$$G_{GAIN} = 8R_0 \frac{I_{OUT}}{V_{INP}} = 8 \cdot 27\Omega \cdot \frac{20\text{mA}}{1\text{V}} \approx 4.32 \Rightarrow \frac{R_1}{R_2} = 4.32 - 1 = 3.32$$

Observing the boundary conditions the following values are obtained for the external components:

$$R_1 \approx 33.2\text{k}\Omega \quad R_2 = 10\text{k}\Omega \quad R_0 = 27\Omega \quad R_5 = 39\Omega \quad R_L = 0 \dots 600\Omega \quad C_1 = 2.2\mu\text{F}$$

Typical 2-wire application with an input signal referenced to ground

In a 2-wire version (cf. *Figure 8*) system supply voltage V_S is connected up to pin 11 ($RS+$) and pin 10 (VCC) to pin 9 ($RS-$). The ground of the IC at pin 14 (GND) is connected to the node between resistor R_5 and load resistor R_L . IC ground (GND) is **not** the same as system ground ($Ground$). The output signal is picked up via load resistor R_L which connects current output I_{OUT} to the system ground.

It must be ensured that in 2-wire operation an additional current load (use of current/voltage source) is limited to 4mA due to the domestic current supply and limitation.

For output current I_{OUT} the following applies according to Equations (1) (2) and (4):

$$I_{OUT} = V_{INP} \cdot \frac{G_{Gain}}{8R_0} + I_{SET} \quad \text{with } G_I = G_{GAIN} = 1 + \frac{R_1}{R_2} \quad \text{and } I_{SET} = \frac{V_{REF}}{2R_0} \cdot \frac{R_4}{R_3 + R_4}$$

Industrial V/I Converter and Protector IC AM462

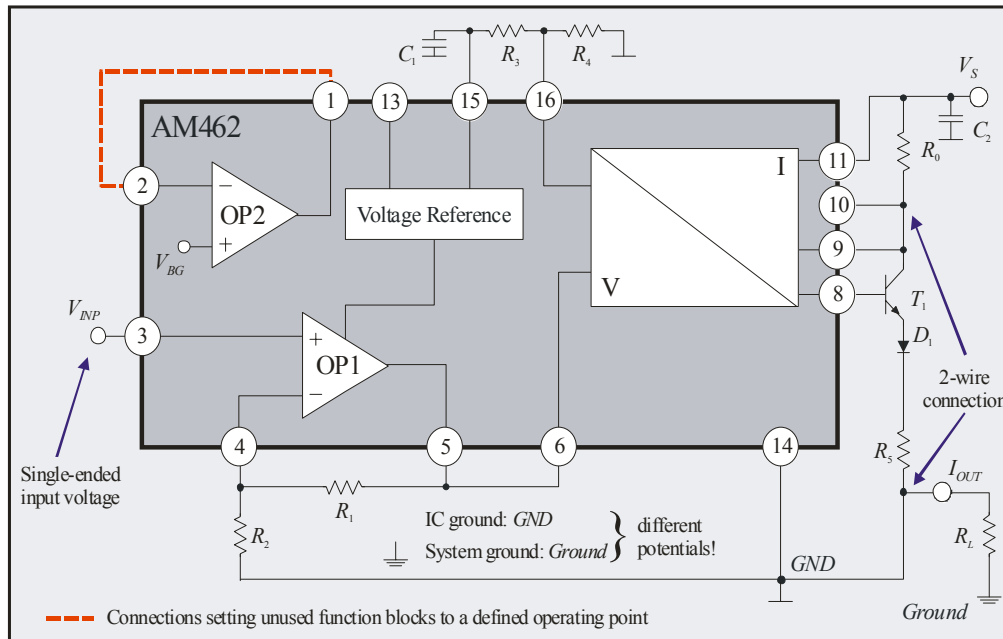

Figure 8: Typical 2-wire operation for input signals referenced to ground

Example : 4...20mA Voltage-To-Current Converter in 2-wire application

To convert a signal of $V_{INP} = 0...1V$ at the OP1 input the external components are to be dimensioned in such a way that the output current has a range of 4...20mA. The following applies:

$$I_{OUT} = V_{INP} \cdot \frac{G_{GAIN}}{8R_0} + I_{SET} = V_{INP} \cdot \frac{G_{GAIN}}{8R_0} + 4mA$$

With $R_0 = 27\Omega$ and $I_{SET} = 4mA$. Equation(4) produces the following relation between resistor R_3 and R_4 :

$$\frac{R_3}{R_4} = \frac{V_{REF}}{2R_0 I_{SET}} - 1 = \frac{5V}{2 \cdot 27\Omega \cdot 4mA} - 1 \approx 22.15$$

and thus the following value for the gain:

$$G_{GAIN} = 8R_0 \frac{I_{OUT\max} - I_{SET}}{V_{INP}} = 8 \cdot 27\Omega \cdot \frac{16mA}{1V} = 3.456 \Rightarrow \frac{R_1}{R_2} = 3.456 - 1 = 2.456$$

Observing the given boundary conditions, the following values are obtained for the external components:

$$\begin{array}{llll} R_1 \approx 24.56k\Omega & R_2 = 10k\Omega & R_3 \approx 44.3k\Omega & R_4 = 2k\Omega \\ R_0 = 27\Omega & R_5 = 39\Omega & R_L = 0...600\Omega & C_1 = 2.2\mu F \quad C_2 = 100nF \end{array}$$

Industrial V/I Converter and Protector IC

AM462

Application for an input signal with an offset

It is not uncommon for input signals to have an offset (e.g. of 0.5V for a 0,5...4.5V input signal or 1V for a 1..6V input signal). For signals such as these an offset current is generated at the IC output also when $I_{SET} = 0$. In this case the output current will be always: $I_{OUT} \neq 0$. The circuit can then be dimensioned as described in the following.

According to Equation (2) the following applies for a required current swing at the output of $\Delta I_{OUT} = I_{OUTmax} - I_{OUTmin}$:

$$\Delta I_{OUT} = \frac{\Delta V_{PIN6}}{8R_0} \Rightarrow \Delta V_{PIN6} = 8R_0 \Delta I_{OUT} \quad (11)$$

For an input current swing of $\Delta V_{IN} = V_{INmax} - V_{INmin}$ the necessary gain is calculated as:

$$G = \frac{\Delta V_{PIN6}}{\Delta V_{IN}} \quad (12)$$

If $G < 1$, the input signal can be routed directly to pin 6 (*INDAI*) via a voltage divider without OP1 having to be used (see *Figure 9*). With this circuitry the following results:

$$G = \frac{\Delta V_{PIN6}}{\Delta V_{IN}} = \frac{R_7}{R_6 + R_7} \Rightarrow \frac{R_6}{R_7} = \frac{\Delta V_{IN}}{\Delta V_{PIN6}} - 1 \quad (13)$$

From input offset V_{INmin} the following output current is then obtained when $I_{SET} = 0$:

$$I_{OUT}(V_{INmin}) = V_{INmin} \cdot \frac{R_7}{R_6 + R_7} \cdot \frac{1}{8R_0} \quad (14)$$

Using the *SET* pin and Equation 2 the required minimum output current I_{OUTmin} can then be set:

$$I_{OUT} = V_{IN} \cdot \frac{R_7}{R_6 + R_7} \cdot \frac{1}{8R_0} + I_{SET} \quad \text{with} \quad I_{SET} = \frac{V_{REF}}{2R_0} \cdot \frac{R_4}{R_3 + R_4} \quad (15)$$

Example: 4..20mA Voltage-To-Current Converter with Input Signal Offset (3-wire application)

To convert a signal of $V_{IN} = 0.5...4.5V$ the external components are to be dimensioned in such a way that the output current has a range of 4...20mA. The circuitry is shown in *Figure 9*. OP1 is used as input stage to have a high ohmic input and to profite from internal overvoltage protection.

OP2 is not used here. It is, however, available to the user as an additional OP. The pin 1 and 2 has to be connected.

With reference to Equation (11) and with $R_0 = 27\Omega$, a voltage swing is obtained at pin 6 of:

$$\Delta V_{PIN3} = \Delta V_{PIN6} = 8R_0 \Delta I_{OUT} = 8 \cdot 27\Omega \cdot 16mA = 3.456V$$

Industrial V/I Converter and Protector IC AM462

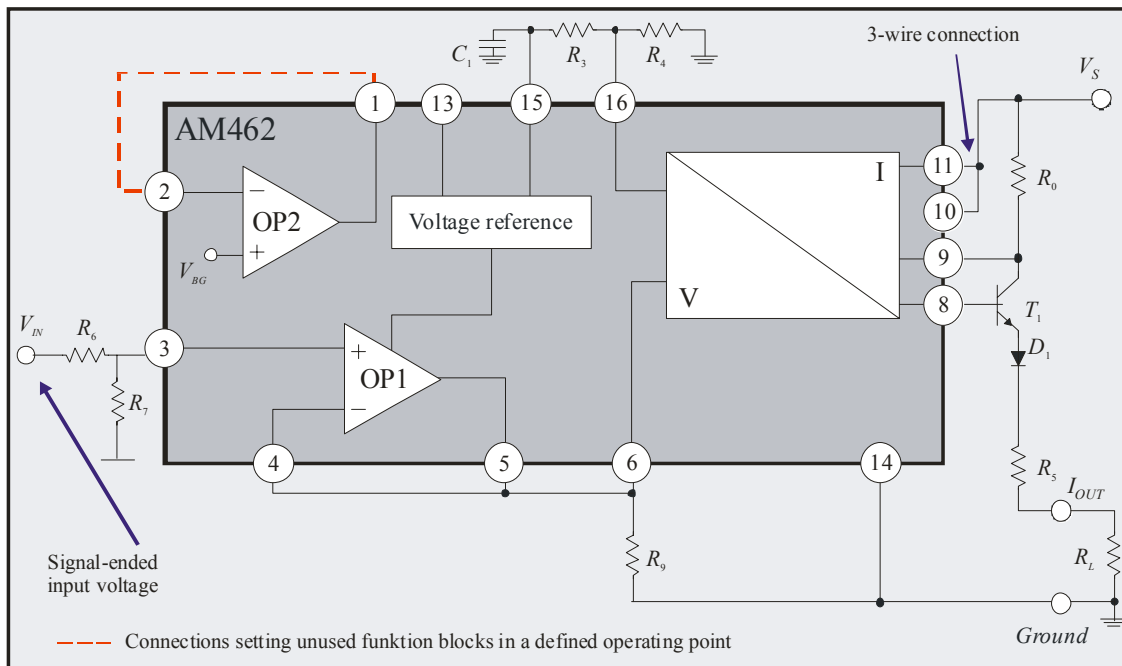

Figure 9: Converting an input signal with an input signal offset (3-wire-application)

Using Equation (13) the following applies:

$$\frac{R_6}{R_7} = \frac{\Delta V_{IN} - \Delta V_{PIN6}}{\Delta V_{PIN6}} = \frac{4V - 3.456V}{3.456V} \approx 0.157 \Rightarrow R_7 = 6.35 \cdot R_6$$

According to Equation (14) the minimum output current generated by the input offset is calculated as:

$$I_{OUT \min} = V_{IN \min} \cdot \frac{R_7}{R_6 + R_7} \cdot \frac{1}{8R_0} = 0.5V \cdot \frac{6.37}{6.37 + 1} \cdot \frac{1}{8 \cdot 27\Omega} \approx 2mA$$

To obtain an output current of $I_{OUT} = 4...20mA$, according to the above a current of $I_{SET} = 2mA$ must then be added. With reference to Equation (5) the ratio of R_3 to R_4 is calculated thus:

$$I_{SET} = 2mA = \frac{V_{REF}}{2R_0} \cdot \frac{R_4}{R_3 + R_4} \Rightarrow \frac{R_3}{R_4} = \frac{V_{REF}}{2R_0 I_{SET}} - 1 = \frac{5V}{2 \cdot 27\Omega \cdot 2mA} - 1 \approx 45.3$$

Observing the given boundary conditions, the following values are obtained for the external components:

$$\begin{aligned} R_0 &= 27\Omega & R_6 &\approx 10k\Omega & R_7 &= 63.7k\Omega & R_3 &= 90.6k\Omega & R_4 &= 2k\Omega \\ R_5 &= 39\Omega & R_L &= 0...600\Omega & C_1 &= 2.2\mu F & R_9 &= 47k\Omega \end{aligned}$$

Industrial V/I Converter and Protector IC AM462

BLOCK DIAGRAM AND PINOUT

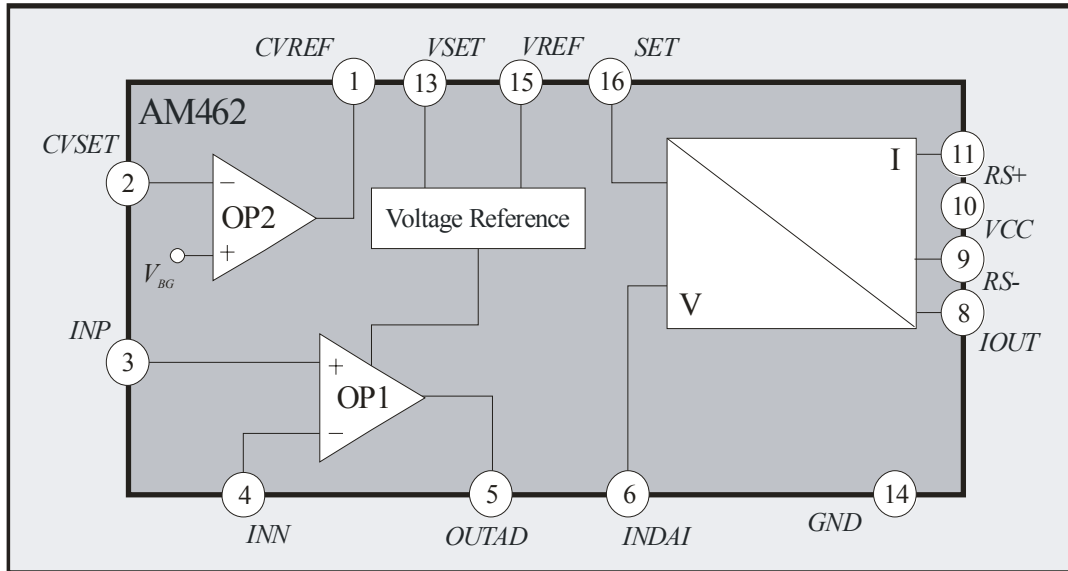

Figure 10: Block diagram of AM462

PIN	NAME	EXPLANATION
1	CVREF	Current/Voltage reference
2	CVSET	Current/Voltage reference set
3	INP	Positive input
4	INN	Negative input
5	OUTAD	System amplification output
6	INDAI	Current output stage input
7	N.C.	Not connected
8	IOUT	Current output
9	RS-	Sensing resistor -
10	VCC	Supply voltage
11	RS+	Sensing resistor +
12	N.C.	Not connected
13	VSET	Reference voltage source set
14	GND	IC ground
15	VREF	Reference voltage source output
16	SET	Output offset current set

Table 1: AM462 Pin out

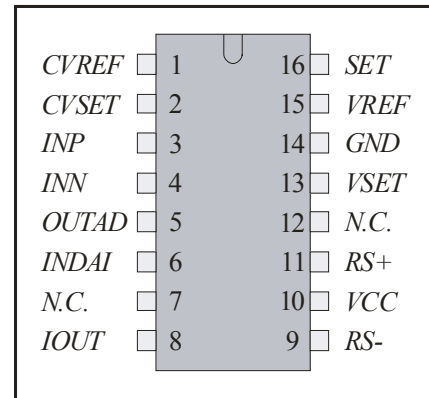

Figure 11: AM462 Pin out

Industrial V/I Converter and Protector IC AM462

EXAMPLE APPLICATIONS

- *Application as a voltage-to-current converter IC*

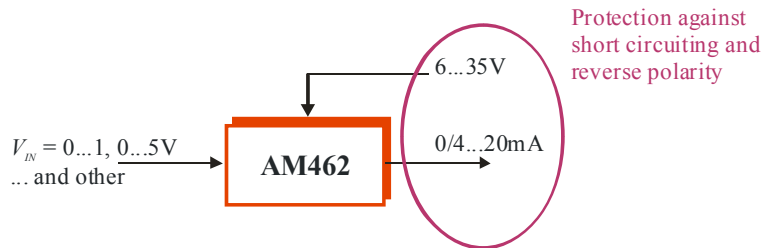

Figure 12: Application as a current converter IC

- *Converting a 0.5...4.5V sensor (voltage) signal*

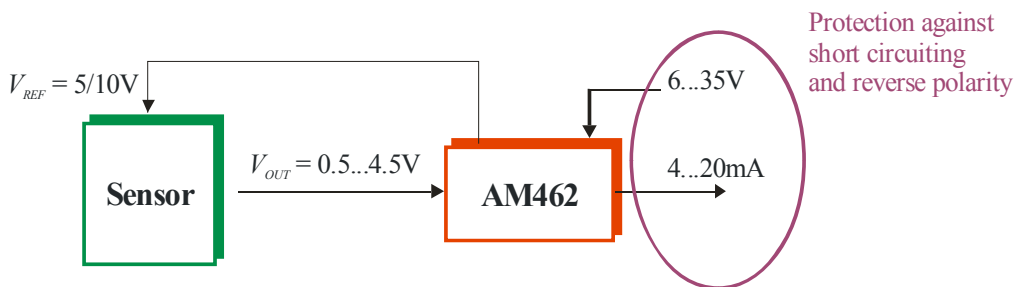

Figure 13: Converting a 0.5...4.5V sensor signal

- *Configuration as a peripheral processor IC [2]*

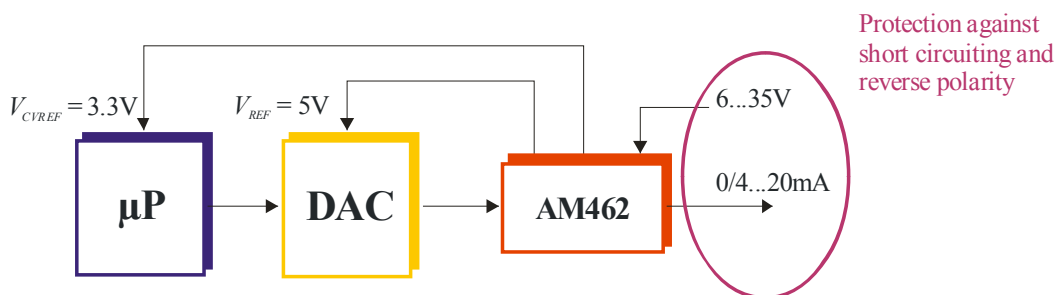

Figure 14: Configuration as a peripheral processor IC and supply unit

Industrial V/I Converter and Protector IC AM462

- *Application as an analog output IC and supply unit for sensors*

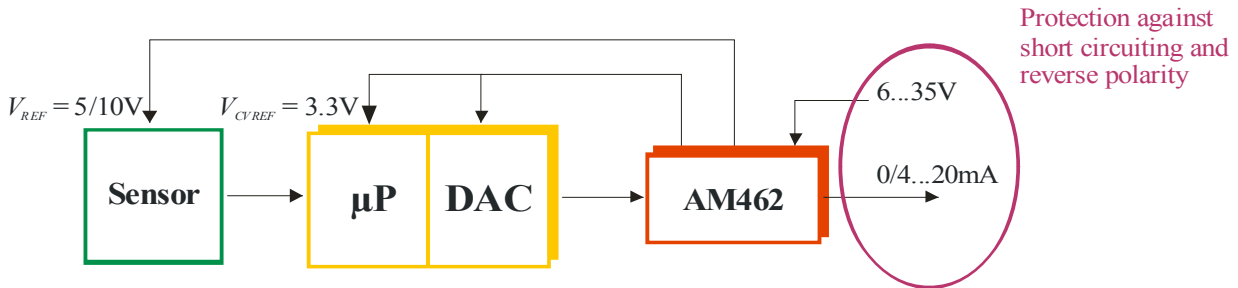

Figure 15: Output IC and supply unit in sensor applications

- *Application as a front-end and back-end IC for microprocessors*

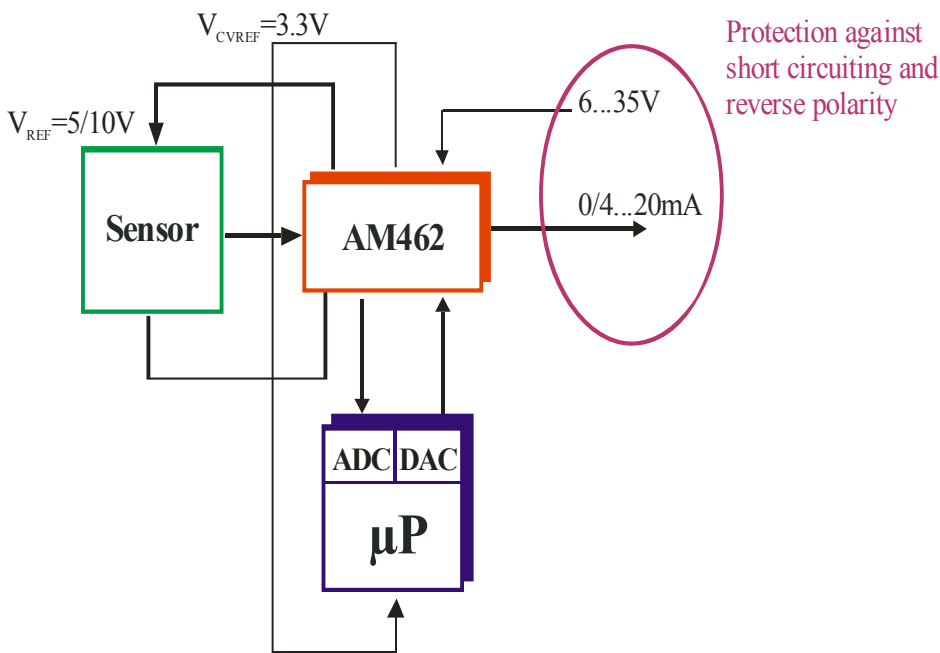

Figure 16: Application as an analog front end and back end for microprocessors
(Frame ASIC concept)

Industrial V/I Converter and Protector IC AM462

DELIVERY

The AM462 V/I converter and protector IC is available as the following packages:

- SSOP16
- SO16(n)
- Dice on 5" blue foil (on request)

PACKAGE DIMENSIONS

Please see our website (data sheets: package.pdf).

FURTHER READING

www.analogmicro.de

- [1] The Frame ASIC concept: See:
- [2] PR1011 - The AM462 can be used as an integrated solution to interface a microprocessor to the industrial 4...20mA network. See: Technical Articles:
PR1012 - Voltage-to-current converter IC for 2-wire current loop applications (4...20mA). See: Technical Articles
AN1014 - Interfacing the μ Processor with the 4...20mA current loop signal (PLC). See: Application

NOTES

Analog Microelectronics reserves the right to make amendments to any dimensions, technical data or other information contained herein without further notice.

The logo for Analog Microelectronics features the text "analog microelectronics" in a bold, red, sans-serif font, with "integrated circuits" in a smaller, black, sans-serif font below it. A red curved line arches over the text, and a black curved line arches under it.

Analog Microelectronics GmbH
An der Fahrt 13, D – 55124 Mainz

Phone: +49 (0)6131/91 073-0
Fax: +49 (0)6131/91 073-30
Internet:
<http://www.analogmicro.de>
Email: info@analogmicro.de

Oktober 2007 – Rev.2.5 -Page 20/20