

PRINCIPLE FUNCTION

Amplification and conversion of voltage signals referenced to ground
 Integrated protection for IC and external components
 Integrated, adjustable current/voltage sources for external components

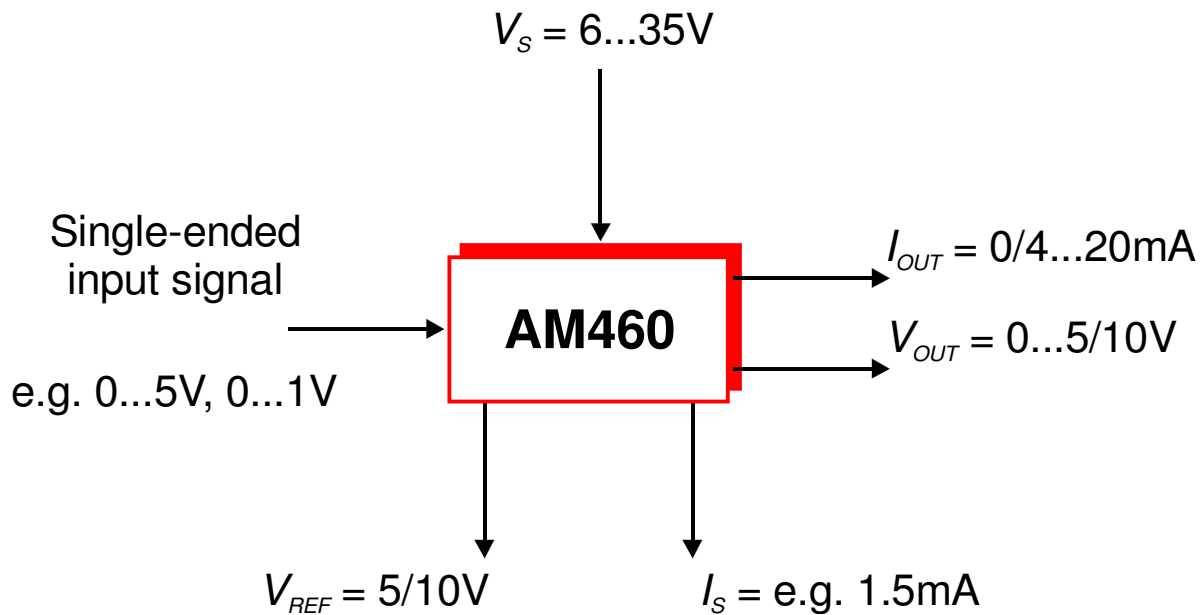

TYPICAL APPLICATIONS

- Peripheral processor IC (see Figure 12 on page 17)
- Industrial protector and output IC for microprocessors (Frame ASIC concept [1])
- Impedance converter
- Adjustable voltage and current source (supply unit)
- Voltage regulator with additional functions

TABLE OF CONTENTS

Features	3
General Description	3
Block Diagram	3
Electrical Specifications	4
Boundary Conditions	6
Detailed Description of Functions	6
Operating AM460	8
General information on 2- and 3-wire applications and the use of the current output	8
Setting the voltage gain using the voltage output	9
Setting the output current range using the current output	9
Selecting the supply voltage	9
Connecting OP2 as a current source	10
Connecting OP2 as a voltage reference	11
Operating AM460: Important Points to Note	12
Applications	12
Typical 3-wire application with an input signal referenced to ground	12
Typical 2-wire application with an input signal referenced to ground	14
Block Diagram and Pinout	16
Examples of Possible Applications	17
Delivery	18
Further Reading	18

TABLE OF FIGURES

Table 1: AM460 pinout	16
Figure 1: Block diagram of AM460	3
Figure 2: Block diagram of AM460 with external components (3-wire circuit for current output)	7
Figure 3: Difference between 2- and 3-wire operation	8
Figure 4: Working range in conjunction with the load resistor	10
Figure 5: Connecting up a constant current source	10
Figure 6: Connecting up a voltage reference	11
Figure 7: Typical application for input signals referenced to ground	13
Figure 8: Typical 2-wire application for input signals referenced to ground	14
Figure 9: Block diagram of AM460	16
Figure 10: Pinout	16
Figure 11: Application for input signals referenced to ground (protected output stage, impedance converter etc.)	17
Figure 12: Complex configuration as a peripheral processor IC	17
Figure 13: Conversion of a 0.5...4.5V sensor signal	17

FEATURES

- Supply voltage: 6...35V
- Wide working temperature range: $-40^{\circ}\text{C} \dots +85^{\circ}\text{C}$
- Adjustable integrated reference voltage source: 4.5 to 10V
- Additional voltage/current source
- Operational amplifier with integrated driver stage
- Adjustable amplification
- Analogue parallel voltage (0...5/10V) and current output (0/4...20mA)
- Protection against reverse polarity and short-circuiting
- Output current limit
- Low-cost device: replaces a number of discrete elements
- 2- and 3-wire operation

GENERAL DESCRIPTION

AM460 is a universal converter and amplifier IC with a number of additional functions. The IC basically consists of an amplifier, whose gain can be set externally, and parallel output stages which can condition signals referenced to ground in industrial voltage and current signals. An additional reference voltage source for the supply of external components is also included in the device. A further operational amplifier can be connected up as a current source, voltage reference or comparator.

One of the main features of the IC is its integrated protective circuitry. The device is protected against reverse polarity, short-circuiting and has a built-in output current limit. Amplifier IC AM460 enables industrial standard voltage (e.g. 0–5/10V) and current loop (e.g. 0/4–20mA) signals to be produced relatively easily.

BLOCK DIAGRAM

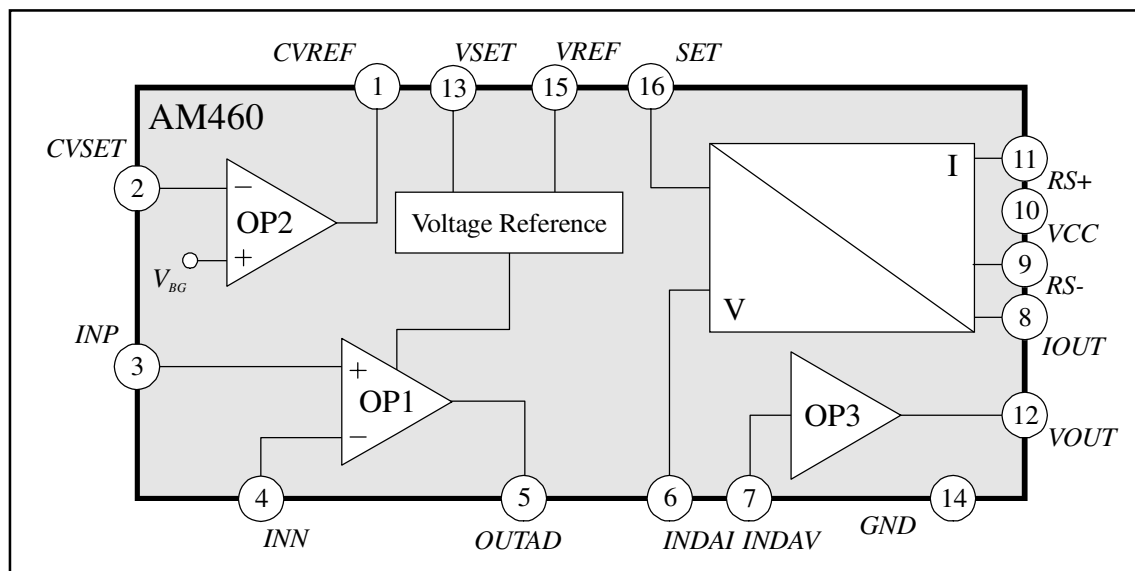

Figure 1: Block diagram of AM460

ELECTRICAL SPECIFICATIONS

$T_{amb} = 25^{\circ}\text{C}$, $V_{CC} = 24\text{V}$, $V_{REF} = 5\text{V}$, $I_{REF} = 1\text{mA}$ (unless otherwise stated), currents flowing into the IC are negative

Parameter	Symbol	Conditions	Min.	Typ.	Max.	Unit
Supply Voltage Range	V_{CC}		6		35	V
Quiescent Current	I_{CC}	$T_{amb} = -40\dots+85^{\circ}\text{C}$, $I_{REF} = 0\text{mA}$			1.5	mA
Temperature Specifications						
Operating	T_{amb}		-40		85	$^{\circ}\text{C}$
Storage	T_{st}		-55		125	$^{\circ}\text{C}$
Junction	T_J				150	$^{\circ}\text{C}$
Thermal Resistance	Θ_{ja}	DIL16 plastic package		70		$^{\circ}\text{C}/\text{W}$
	Θ_{ja}	SO16 narrow plastic package		140		$^{\circ}\text{C}/\text{W}$
Voltage Reference						
Voltage	V_{REF}	V_{SET} not connected	4.75	5.00	5.25	V
	V_{REF10}	$V_{SET} = GND$, $V_{CC} \geq 11\text{V}$	9.5	10.0	10.5	V
Trim Range	V_{REFADJ}		4.5		V_{REF10}	V
Current	I_{REF}^*		0		10.0	mA
V_{REF} vs. Temperature	dV_{REF}/dT	$T_{amb} = -40\dots+85^{\circ}\text{C}$		± 90	± 140	ppm/ $^{\circ}\text{C}$
Line Regulation	dV_{REF}/dV	$V_{CC} = 6\text{V}\dots35\text{V}$		30	80	ppm/V
	dV_{REF}/dV	$V_{CC} = 6\text{V}\dots35\text{V}$, $I_{REF} \approx 5\text{mA}$		60	150	ppm/V
Load Regulation	dV_{REF}/dI			0.05	0.10	%/mA
	dV_{REF}/dI	$I_{REF} \approx 5\text{mA}$		0.06	0.15	%/mA
Load Capacitance	C_L		1.9	2.2	5.0	μF
Current/Voltage Source OP2						
Internal Reference	V_{BG}		1.20	1.27	1.35	V
V_{BG} vs. Temperature	dV_{BG}/dT	$T_{amb} = -40\dots+85^{\circ}\text{C}$		± 60	± 140	ppm/ $^{\circ}\text{C}$
Current Source: $I_{CV} = V_{BG}/R_{SET}$, from Figure 5						
Adjustable Current Range	I_{CV}^*		0		10	mA
Output Voltage	V_{CV}	$V_{CC} < 19\text{V}$	V_{BG}		$V_{CC} - 4$	V
	V_{CV}	$V_{CC} \geq 19\text{V}$	V_{BG}		15	V
Voltage Source: $V_{CV} = V_{BG} \cdot (1 + R_7 / R_6)$, from Figure 6						
Adjustable Voltage Range	V_{CV}	$V_{CC} < 19\text{V}$	0.4		$V_{CC} - 4$	V
	V_{CV}	$V_{CC} \geq 19\text{V}$	0.4		15	V
Output Current	I_{CV}^*	Source			10	mA
	I_{CV}	Sink			-100	μA
Load Capacitance	C_L	Source mode	0	1	10	nF
Operational Amplifier Gain Stage (OP1)						
Adjustable Gain	G_{GAIN}		1			
Input Range	I_R	$V_{CC} < 10\text{V}$	0		$V_{CC} - 5$	V
	I_R	$V_{CC} \geq 10\text{V}$	0		5	V
Power Supply Rejection Ratio	$PSRR$		80	90		dB
Offset Voltage	V_{OS}			± 0.5	± 2	mV
V_{OS} vs. Temperature	dV_{OS}/dT			± 3	± 7	$\mu\text{V}/^{\circ}\text{C}$

Parameter	Symbol	Conditions	Min.	Typ.	Max.	Unit
Operational Amplifier Gain Stage (OP1) (cont.)						
Input Bias Current	I_B			10	25	nA
I_B vs. Temperature	dI_B/dT			7	20	pA/°C
Output Voltage Limit	V_{LIM}			V_{REF}		V
Output Voltage Range	V_{OUTAD}	$V_{CC} < 10V$	0		$V_{CC} - 5$	V
	V_{OUTAD}	$V_{CC} \geq 10V$	0		V_{REF}	V
Load Capacitance	C_L				250	pF
Operational Amplifier Output Stage (OP3)						
Internal Gain	G_{OP}		2.15	2.20	2.25	
Input Range	IR	$V_{CC} < 11V$	0		$V_{CC} - 5$	V
	IR	$V_{CC} \geq 11V$	0		6	V
Power Supply Rejection Ratio	$PSRR$		80	90		dB
Offset Voltage	V_{OS}			± 0.5	± 2	mV
V_{OS} vs. Temperature	dV_{OS}/dT			± 3	± 7	$\mu V/^\circ C$
Input Bias Current	I_B			10	25	nA
I_B vs. Temperature	dI_B/dT			7	20	pA/°C
Output Voltage Range	V_{OUT}	$V_{CC} < 19V$	0		$V_{CC} - 5$	V
	V_{OUT}	$V_{CC} \geq 19V$	0		14	V
Output Current Limitation	I_{LIM}	$V_{OUT} \geq 10V$	5	7	10	mA
Output Current	I_{OUT}		0		I_{LIM}	mA
Load Resistance	R_L		2			k Ω
Load Capacitance	C_L				500	nF
V/I Converter						
Internal Gain	G_{VI}			0.125		
Trim Range		Adjustable by R_0	0.75	1.00	1.25	
Voltage Range at R_0 FS	V_{R0FS}		350		750	mV
Offset Voltage	V_{OS}	$\beta_F \geq 100$		± 2	± 4	mV
V_{OS} vs. Temperature	dV_{OS}/dT	$\beta_F \geq 100$		± 7	± 14	$\mu V/^\circ C$
Input Resistance	R_{IN}		120	160		k Ω
R_{IN} vs. Temperature	dR_{IN}/dT		0.2	0.3		k $\Omega/^\circ C$
Output Offset Current	I_{OUTOS}	3-wire operation		-25	-35	μA
I_{OUTOS} vs. Temperature	dI_{OUTOS}/dT	3-wire operation		16	26	nA/°C
Output Offset Current	I_{OUTOS}	2-wire operation		9.5	14	μA
I_{OUTOS} vs. Temperature	dI_{OUTOS}/dT	2-wire operation		6	8	nA/°C
Output Control Current	I_{OUTC}	2-wire operation, $V_{R0}/100mV$		6	8	μA
I_{OUTC} vs. Temperature	dI_{OUTC}/dT	2-wire operation		-10	-15	nA/°C
Output Voltage Range	V_{OUT}	$V_{OUT} = R_L I_{OUT}, V_{CC} < 18V$	0		$V_{CC} - 6$	V
	V_{OUT}	$V_{OUT} = R_L I_{OUT}, V_{CC} \geq 18V$	0		12	V
Output Current Range FS	I_{OUTFS}	$I_{OUT} = V_{R0}/R_0, 3$ -wire operation		20		mA
Output Resistance	R_{OUT}		0.5	1.0		M Ω
Load Capacitance	C_L		0		500	nF

Parameter	Symbol	Conditions	Min.	Typ.	Max.	Unit
SET Stage						
Internal Gain	G_{SET}			0.5		
Input Voltage	V_{SET}		0		1.15	V
Offset Voltage	V_{OS}			±0.5	±1.5	mV
V_{OS} vs. Temperature	dV_{OS}/dT			±1.6	±5	µV/°C
Input Bias Current	I_B			8	20	nA
I_B vs. Temperature	dI_B/dT			7	18	pA/°C
Protection Functions						
Voltage Limitation at R_0	V_{LIMR0}	$V_{R0} = V_{INDAI} G_{VI}, SET = GND$	580	635	690	mV
	V_{LIMR0}	$V_{INDAI} = 0, V_{R0} = G_{SET} V_{SET}$	580	635	690	mV
Protection against reverse polarity		Ground vs. V_S vs. V_{OUT}			35	V
		Ground vs. V_S vs. I_{OUT}			35	V
Current with reverse polarity		Ground = 35V, $V_S = I_{OUT} = 0$		4.5		mA
System Parameters						
Nonlinearity		Ideal input		0.05	0.15	%FS

* In 2-wire operation a maximum current of $I_{OUTmin} - I_{CC}$ is valid

BOUNDARY CONDITIONS

Parameter	Symbol	Conditions	Min.	Typ.	Max.	Unit
Sense Resistor	R_0	$I_{OUTFS} = 20mA$	17	27	38	Ω
	R_0	$c = 20mA/I_{OUTFS}$	$c \cdot 17$	$c \cdot 27$	$c \cdot 38$	Ω
Stabilisation Resistor	R_5	$I_{OUTFS} = 20mA$	35	40	45	Ω
	R_5	$c = 20mA/I_{OUTFS}$	$c \cdot 35$	$c \cdot 40$	$c \cdot 45$	Ω
Load Resistor	R_L	Only for 3-wire operation	0		600	Ω
Sum Gain Resistors	$R_1 + R_2$		20		200	kΩ
Sum Offset Resistors	$R_3 + R_4$		20		200	kΩ
V_{REF} Capacitor	C_1	Ceramic	1.9	2.2	5.0	µF
Output Capacitor	C_2	Only for 2-wire operation	90	100	250	nF
D_1 Breakdown Voltage	V_{BR}		35	50		V
T_1 Forward Current Gain	β_F	BCX54/55/56, for example	50	150		

DETAILED DESCRIPTION OF FUNCTIONS

AM460 is a modular, universal converter and protector IC which has been specially developed for the conditioning of voltage signals referenced to ground. It has been conceived for both 2- and 3-wire operation¹ in industrial applications (cf. application on page 8). The functions of AM460 are depicted in the block diagram (Figure 2) which also illustrates how few external components are required for the operation of this particular device. Electrical specifications for the external components are given on page 6.

¹The principle of AM460 is such that only the current output can be used in 2-wire operation.

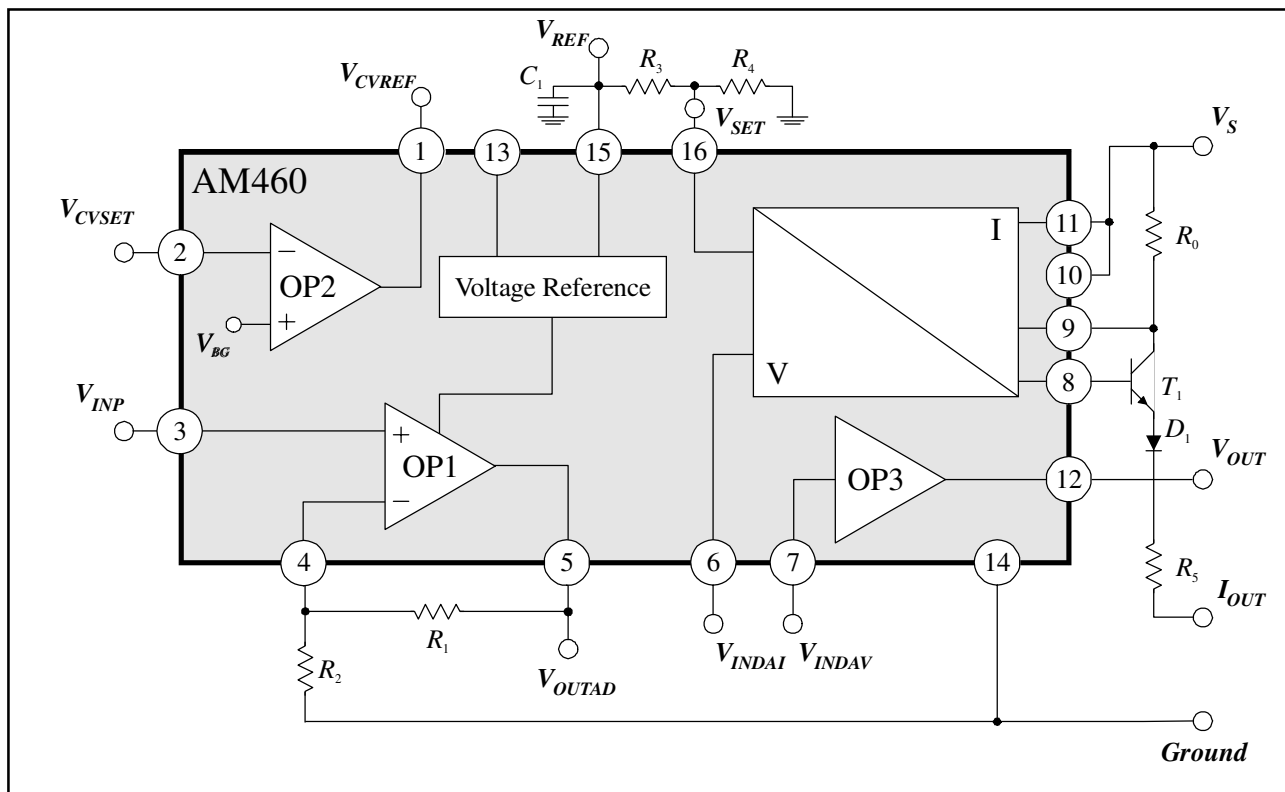

Figure 2: Block diagram of AM460 with external components (3-wire circuit for current output)

AM460 consist of several modular function blocks (operational amplifiers, voltage-to-current converters and references) which depending on external configurations can either be switched together or operated separately (see the basic circuitry in Figure 2):

1. *Operational amplifier stage OP1* enables a positive voltage signal to be amplified. OP1 gain G_{GAIN} can be set via external resistors R_1 and R_2 . Protective circuitry against overvoltage is integrated into the chip, limiting the voltage to the set value of the reference voltage. Output voltage V_{OUTAD} at pin *OUTAD* is calculated as:

$$V_{OUTAD} = V_{INP} \cdot G_{GAIN} \text{ with } G_{GAIN} = 1 + \frac{R_1}{R_2} \quad (1)$$

where V_{INP} is the voltage at OP1 input pin *INP*.

2. Using the current-limited *operational amplifier stage OP3* with its integrated protection against reverse polarity an industrial voltage signal (V_{OUT}) can be realised. The internal amplification of OP3 is set to a fixed value of $G_{OP} = 2.2$. The output is configured as a driver so that OP3 is particularly suitable as an output stage. For OP3 output voltage V_{OUT} at pin *VOUT* of the IC the following applies:

$$V_{OUT} = G_{OP} \cdot V_{INDAV} \quad (2)$$

with V_{INDAV} the voltage at pin *INDAV* (OP3 input).

3. The voltage-to-current converter (V/I converter) provides a voltage-controlled current signal at IC output *IOUT* (pin 8) which activates an external transistor T_1 ; this in turn supplies the actual output current I_{OUT} . To

reduce power dissipation the transistor is an external component and protected against reverse polarity by an additional diode D_1 . Via pin SET an offset current I_{SET} can be set at output I_{OUT} (with the help of the internal voltage reference and an external voltage divider as shown in Figure 2, for example). External resistor R_0 permits the output current to be finely adjusted with parallel operation of current and the voltage output. For the output current provided by T_1 the following ratio applies:

$$I_{OUT} = \frac{V_{INDAI}}{8R_0} + I_{SET} \quad \text{with} \quad I_{SET} = \frac{V_{SET}}{2R_0} \quad (3)$$

with V_{INDAI} the voltage at $INDAI$ and V_{SET} the voltage at pin SET (V/I converter inputs, Figure 2)².

- The AM460 *reference voltage source* enables voltage to be supplied to external components (such as sensors, microprocessors, etc.). The reference voltage value V_{REF} can be set via pin 13 $VSET$. If pin $VSET$ is not connected, $V_{REF} = 5V$; if $VSET$ is switched to ground, $V_{REF} = 10V$. Values between these can be set if two external resistors are used (inserted between pin $VREF$ and pin $VSET$ and between pin $VSET$ and GND).

External (ceramic) capacitor C_1 at pin $VREF$ stabilises the reference voltage. It **must** be connected even if the voltage reference is not in use.

- The additional *operational amplifier stage* OP2 can be used as a current or voltage source to supply external components. OP2's positive input is connected internally to voltage V_{BG} so that the output current or output voltage can be set across a wide range using one or two external resistors.

OPERATING AM460

General information on 2- and 3-wire applications and the use of the current output

In 3-wire operation (cf. Figure 3 right and Figure 7) the ground of the IC (pin GND) is connected up to the external mass of the system *Ground*. The system's supply voltage V_S is connected to pin VCC and pin VCC to pin $RS+$.

In 2-wire operation (cf. Figure 3 left and Figure 7) system supply voltage V_S is connected to pin $RS+$ and pin VCC to $RS-$. The ground of the IC (pin GND) is connected to the node between resistor R_S and load resistor R_L (current output I_{OUT}). IC ground (GND) is **not** the same as system ground (*Ground*)!! The output signal is picked up via load resistor R_L which connects current output I_{OUT} to the system ground.

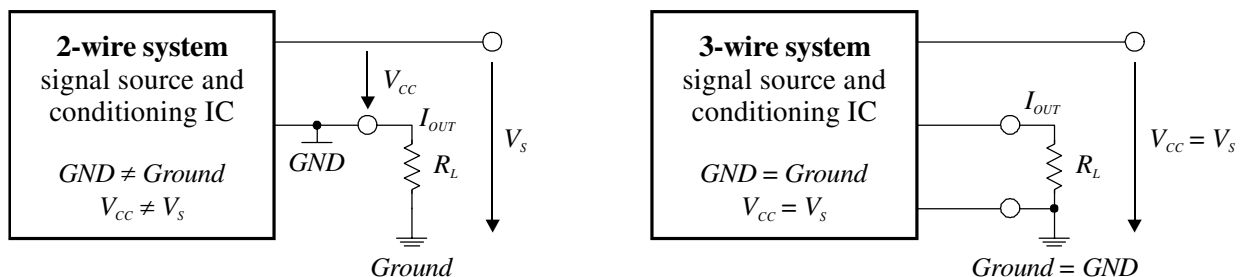

Figure 3: Difference between 2- and 3-wire operation

² The construction of the V/I converter is such that output current I_{OUT} is largely independent of the current amplification β_F of external transistor T_1 . Production-specific variations in the current amplification of the transistors used are compensated for internally by the V/I converter.

In 2-wire operation the IC ground is "virtual" (floating), as with a constant load resistance the supply voltage of the device V_{CC} changes according to the current. As a rule, the following equation applies to 2-wire operation:

$$V_{CC} = V_S - I_{OUT}(V_{IN}) R_L \quad (4)$$

The reason for this is that in 2-wire operation the IC is connected in series to the actual load resistor R_L . This is illustrated in Figure 3.

In 3-wire operation $V_{CC} = V_S$, as the IC ground is connected to the ground of the system.

Setting the voltage gain using the voltage output

Using amplifier stages OP1 and OP3 for signal conditioning the overall gain can be set by selecting suitable external resistors R_1 and R_2 . The transfer function for the output voltage is calculated by multiplying Equations 1 and 2 as follows:

$$V_{OUT} = V_{INP} \cdot G_{GAIN} \cdot G_{OP} \quad (5)$$

with $G_{GAIN} = 1 + R_1/R_2$ and $G_{OP} = 2.2$.

Setting the output current range using the current output

When using amplification stage OP1 together with the V/I converter for signal conditioning the offset of the output current should first be compensated for by suitable selection of resistors R_3 and R_4 . To this end the OP1 input must be connected to ground ($V_{INP} = 0$). With the short circuit at the input and by connecting up V/I converter pin $VSET$ as shown in Figure 2 the values of the output current according to Equation 3 are as follows:

$$I_{OUT}(V_{INDAI} = 0) = I_{SET} = \frac{V_{REF}}{2R_0} \cdot \frac{R_4}{R_3 + R_4} \quad (6)$$

and thus for the ratio of the resistors R_3/R_4 :

$$\frac{R_3}{R_4} = \frac{V_{REF}}{2R_0 I_{SET}} - 1 \quad (7)$$

The output current area is set in conjunction with the selection of external resistors R_1 and R_2 (or fine adjustment with R_0). With Equations 1 and 3 the following is calculated for output current I_{OUT} :

$$I_{OUT} = V_{INP} \frac{G_{GAIN}}{8R_0} + I_{SET} \quad \text{with } G_{GAIN} = 1 + \frac{R_1}{R_2} \quad (8)$$

Selecting the supply voltage

System supply voltage V_S needed to operate AM460 is dependent on the selected mode of operation.

- When using voltage output pin $VOUT$ the minimum V_S needed for operation is determined by the maximum output voltage V_{OUTmax} required by the application. This is expressed as follows:

$$V_S \geq V_{OUTmax} + 5V \quad (9)$$

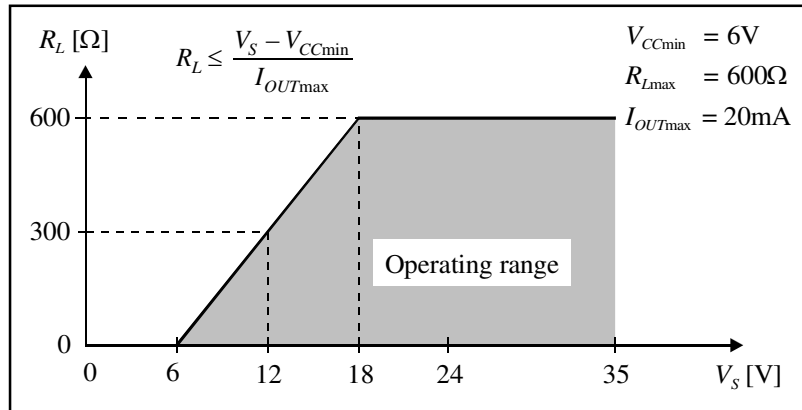

Figure 4: Working range in conjunction with the load resistor

- When using current output pin I_{OUT} (in conjunction with the external transistor) the value of V_S is dependent on that of the relevant load resistor R_L (max. 600Ω) used by the application. The minimum system supply voltage V_S is then:

$$V_S \geq I_{OUT\max} R_L + V_{CC\min} \quad (10)$$

Here, $I_{OUT\max}$ stands for the maximum output current and $V_{CC\min}$ for the minimum IC supply voltage which is dependent on the selected reference voltage:

$$V_{CC\min} \geq V_{REF} + 1V \quad (11)$$

The working range resulting from Equation 10 is described in Figure 4. Example calculations and typical values for the external components can be found in the example applications from page 12 onwards.

Connecting OP2 as a current source

The additional operational amplifier OP2 can easily be connected up as a constant current source. Using the cir-

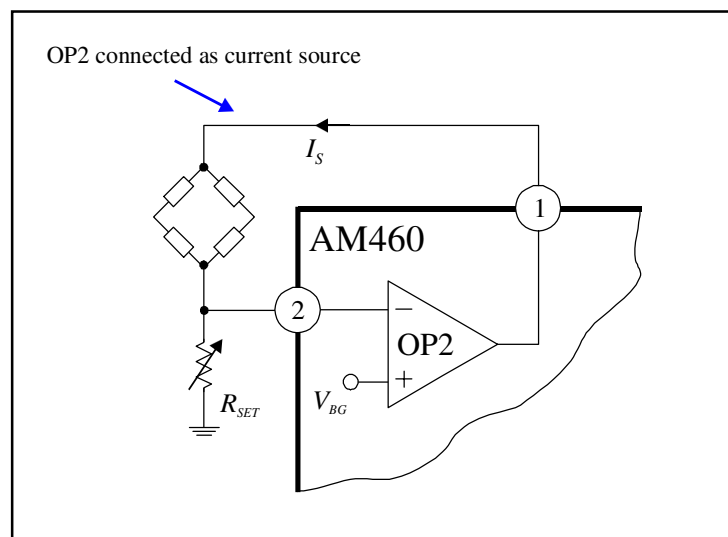

Figure 5: Connecting up a constant current source

cuit in Figure 5 the following applies:

$$I_S = \frac{V_{BG}}{R_{SET}} = \frac{1.27 \text{ V}}{R_{SET}} \quad (12)$$

The bridge symbol represents the component to be supplied with current (e.g. a piezoresistive sensing element or temperature sensor).

Example 1:

A supply current of $I_S = 1\text{mA}$ is to be set. Using Equation 12 the following value is calculated for external resistor R_{SET} , which in turn stipulates the size of the current:

$$R_{SET} = \frac{V_{BG}}{I_S} = \frac{1.27 \text{ V}}{1\text{mA}} = 1.27 \text{ k}\Omega$$

Connecting OP2 as a voltage reference

In addition to the integrated voltage reference OP2 can also be used to supply voltage to external components such as A/D converters and microprocessors, for example. Lower voltages can be generated (e.g. 3.3V) which with the increasing miniaturisation of devices and need for ever lower levels of power dissipation in digital components is today of growing importance.

The additional operational amplifier OP2 can easily be connected up as a voltage reference. Using the circuit in Figure 6 the following applies:

$$V_{CVREF} = V_{BG} \left(1 + \frac{R_6}{R_7} \right) = 1.27 \text{ V} \left(1 + \frac{R_6}{R_7} \right) \quad (13)$$

Example 2:

A voltage of $V_{CVREF} = 3.3\text{V}$ is to be set. Using Equation 13 the following ratio is calculated for external resistors

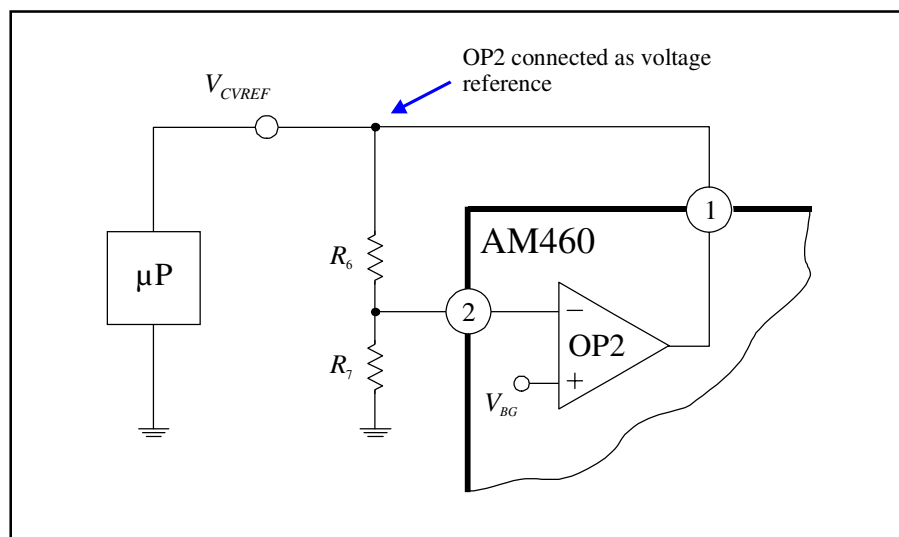

Figure 6: Connecting up a voltage reference

R_6 and R_7 :

$$\frac{R_6}{R_7} = \frac{V_{CVREF}}{V_{BG}} - 1 \approx 2.6 - 1 = 1.6$$

The following example values are produced for the resistors:

$$R_7 = 10\text{k}\Omega \quad R_6 = 16\text{k}\Omega$$

OPERATING AM460: IMPORTANT POINTS TO NOTE

1. When using AM460 it is imperative that external capacitor C_1 (a top-grade ceramic capacitor) is **always** connected (cf. Figure 2). Care must be taken that the value of the capacitor, also within the temperature range, does not exceed the range of values given in the boundary conditions on page 6. In 2-wire operation ceramic capacitor C_2 must also be used (cf. Figure 8)
2. In a 2-wire setup the power consumption of the entire system (AM460 plus all external components, including the configuration resistors) **must not exceed** the sum of I_{OUTmin} (usually 4mA).
3. All AM460 function blocks not required by the application must be connected to a defined (and allowed) potential.
4. With operation of the voltage output the load resistance at pin V_{OUT} must be **at least** 2k Ω .
5. When operating the current output a **maximum** load resistance of 600 Ω is permitted.
6. The values of external resistors R_0, R_1, R_2, R_3, R_4 and R_5 must be selected within the permissible range given in the boundary conditions on page 6.

APPLICATIONS

Typical 3-wire application with an input signal referenced to ground

Figure 7 shows a 3-wire application in which AM460 amplifies and converts a positive voltage signal referenced to ground. The unused blocks (e.g. OP2) have been set to defined operating points. Alternatively, these function groups can also be used here (e.g. to supply external components).

In this particular application, using Equations 1 and 2 output voltage V_{OUT} is calculated as:

$$V_{OUT} = G_V V_{INP} \quad \text{with} \quad G_V = G_{GAIN} \quad G_{OP} = \left(1 + \frac{R_1}{R_2}\right) \cdot 2.2 \quad (14)$$

For output current I_{OUT} the following applies according to Equation 3:

$$I_{OUT} = V_{INP} \cdot \frac{G_I}{8R_0} + I_{SET} \quad \text{with} \quad G_I = G_{GAIN} = 1 + \frac{R_1}{R_2} \quad \text{and} \quad I_{SET} = 0$$

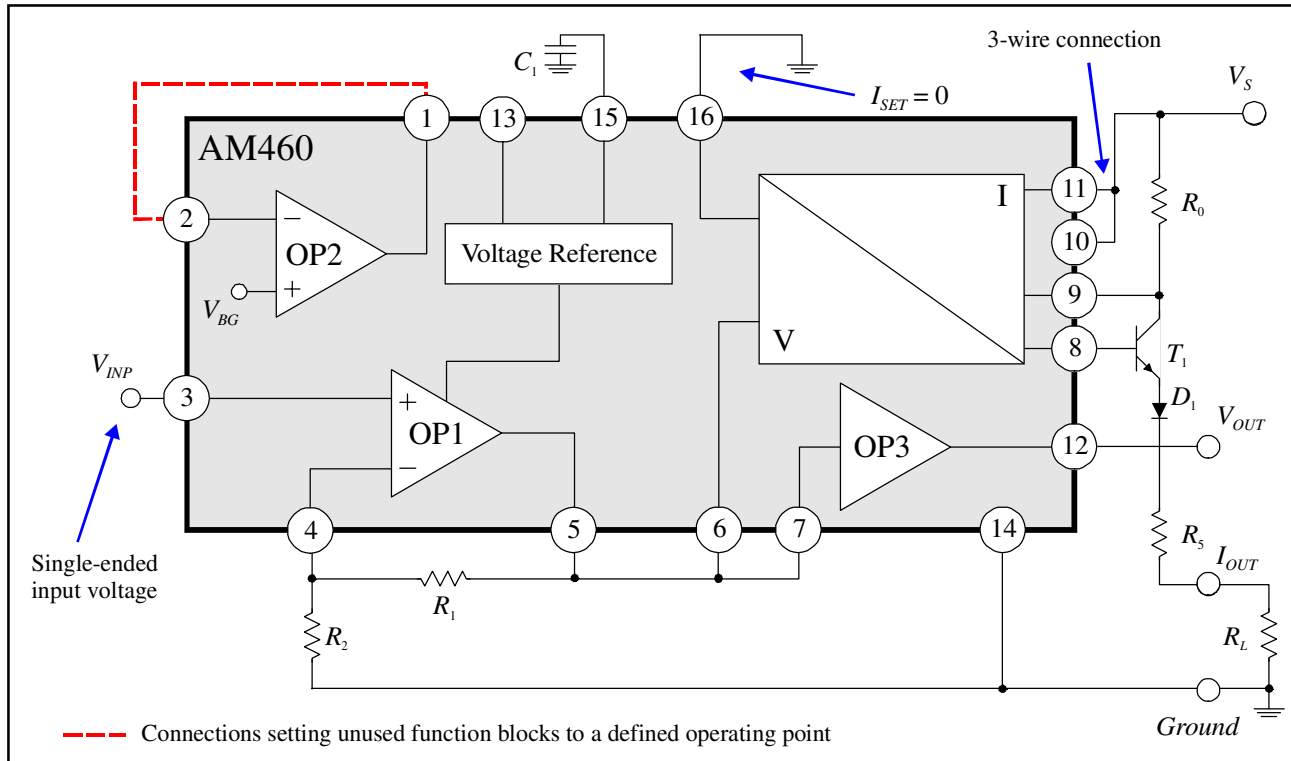

Figure 7: Typical application for input signals referenced to ground

Example 3:

To obtain a signal of $V_{INP} = 0...1V$ at the OP1 input the external components are to be dimensioned in such a way that the output current has a range of $0...20mA$ (i.e. $I_{SET} = 0 \Rightarrow SET = GND$) and the output voltage one of $0...10V$.

Using Equation 14 the output voltage is defined as follows:

$$V_{OUT} = V_{INP} \cdot \left(1 + \frac{R_1}{R_2}\right) \cdot 2.2 \Rightarrow \frac{R_1}{R_2} = \frac{V_{OUT}}{2.2 \cdot V_{INP}} - 1 = \frac{10V}{2.2 \cdot 1V} - 1 \approx 3.55$$

i.e. $G_{GAIN} = 1 + \frac{R_1}{R_2} = 4.55$

The following then applies to the output current:

$$I_{OUT} = V_{INP} \cdot \frac{G_I}{8R_0} + I_{SET} = V_{INP} \cdot \frac{G_{GAIN}}{8R_0} \Rightarrow R_0 = V_{INP} \cdot \frac{G_{GAIN}}{8I_{OUT}} = 1V \cdot \frac{4.55}{8 \cdot 20mA} \approx 28.44\Omega$$

Observing the boundary conditions, the following values are obtained for the external components:

$R_0 \approx 28.44\Omega$	$R_1 \approx 35.5k\Omega$	$R_2 = 10k\Omega$
$R_5 = 39\Omega$	$R_L = 0...600\Omega$	$C_1 = 2.2\mu F$

Typical 2-wire application with an input signal referenced to ground

In 2-wire operation (cf. Figure 8) system supply voltage V_S is connected up to pin $RS+$ and pin VCC to pin $RS-$. The ground of the IC (pin GND) is connected to the node between resistor R_5 and load resistor R_L (current output I_{OUT}). IC ground (GND) is **not** the same as system ground ($Ground$)!! The output signal is picked up via load resistor R_L which connects current output I_{OUT} to the system ground.

For output current I_{OUT} the following applies according to Equation 3:

$$I_{OUT} = V_{INP} \cdot \frac{G_I}{8R_0} + I_{SET} \quad \text{with } G_I = G_{GAIN} = 1 + \frac{R_1}{R_2} \quad \text{and } I_{SET} = \frac{V_{REF}}{2R_0} \cdot \frac{R_4}{R_3 + R_4}$$

Example 4:

To obtain a signal of $V_{INP} = 0 \dots 1V$ at the OP1 input the external components are to be dimensioned in such a way that the output current has a range of $4 \dots 20mA$.

$$I_{OUT} = V_{INP} \cdot \frac{G_I}{8R_0} + I_{SET} = V_{INP} \cdot \frac{G_{GAIN}}{8R_0} + 4mA$$

With $R_0 = 27\Omega$ Equation 7 produces the following:

$$\frac{R_3}{R_4} = \frac{V_{REF}}{2R_0 I_{SET}} - 1 = \frac{5V}{2 \cdot 27\Omega \cdot 4mA} - 1 \approx 22.15$$

and thus the following value for the gain to be set:

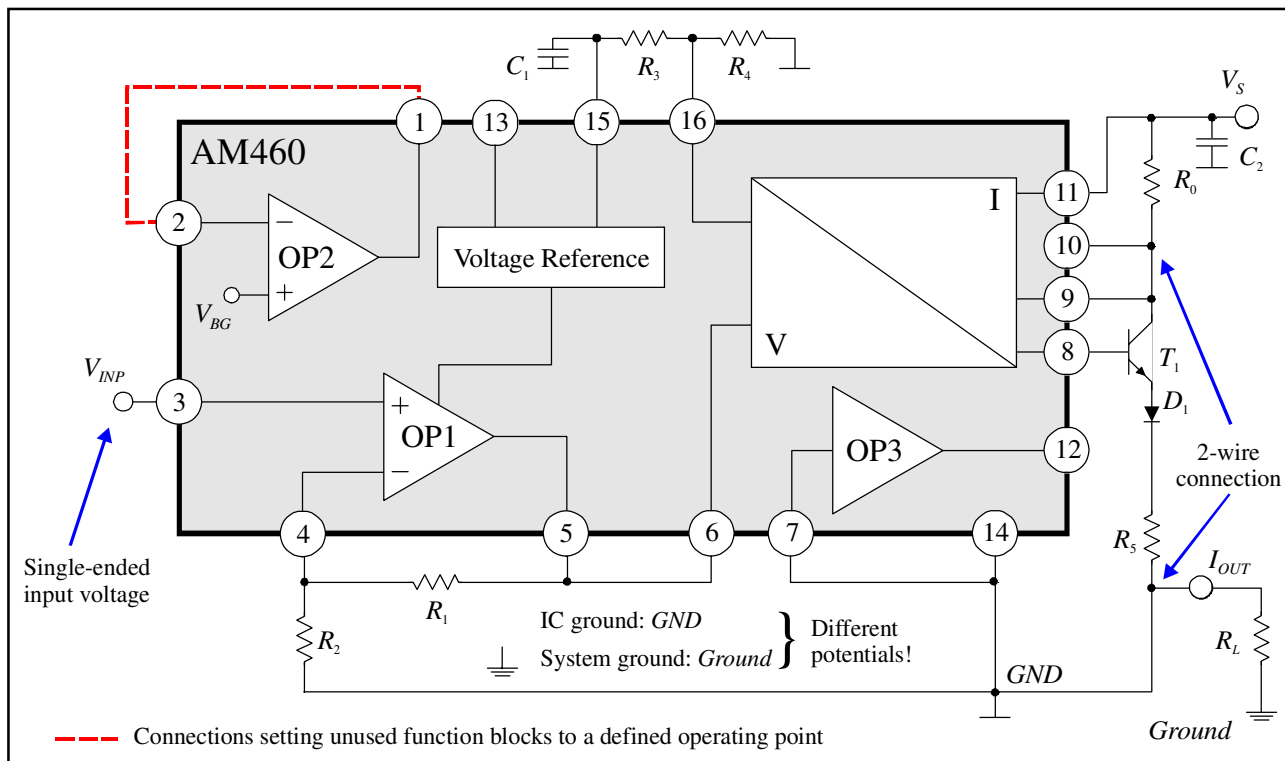

Figure 8: Typical 2-wire application for input signals referenced to ground

$$G_{GAIN} = 8R_0 \frac{I_{OUT\ max} - I_{SET}}{V_{INP}} = 8 \cdot 27\Omega \cdot \frac{16\text{mA}}{1\text{V}} = 3.456 \quad \Rightarrow \quad \frac{R_1}{R_2} = 3.456 - 1 = 2.456$$

Observing the boundary conditions, the following values are obtained for the external components:

$$\begin{array}{lllll} R_1 \approx 24.56\text{k}\Omega & R_2 = 10\text{k}\Omega & R_3 \approx 44.3\text{k}\Omega & R_4 = 2\text{k}\Omega & \\ R_0 = 27\Omega & R_5 = 39\Omega & R_L = 0 \dots 600\Omega & C_1 = 2.2\mu\text{F} & C_2 = 100\text{nF} \end{array}$$

BLOCK DIAGRAM AND PINOUT

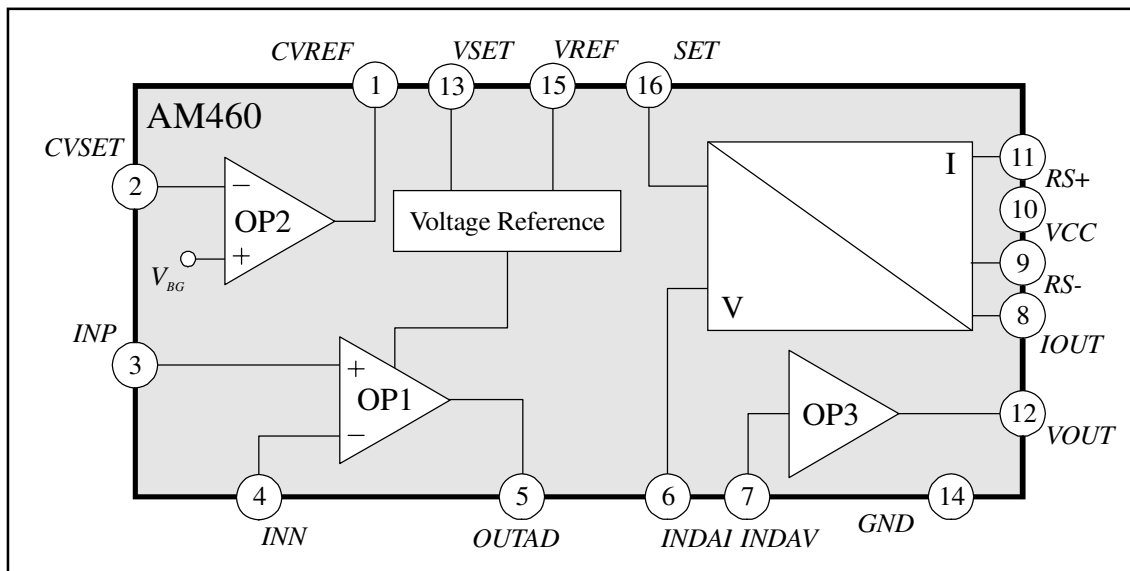

Figure 9: Block diagram of AM460

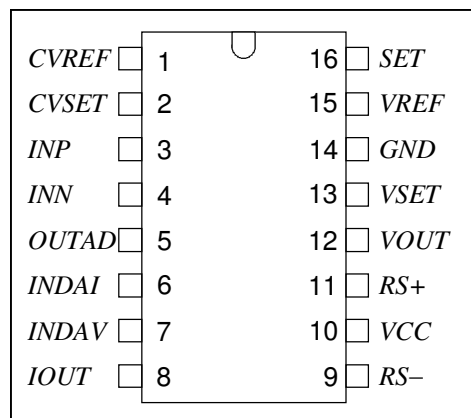

Figure 10: Pinout

PIN	NAME	EXPLANATION
1	CVREF	Current/Voltage reference
2	CVSET	Current/Voltage reference set
3	INP	Positive input
4	INN	Negative input
5	OUTAD	System amplification output
6	INDAI	Current output stage input
7	INDAV	Voltage output stage input
8	IOUT	Current output
9	RS-	Sensing resistor -
10	VCC	Supply voltage
11	RS+	Sensing resistor +
12	VOUT	Voltage output
13	VSET	Reference voltage source set
14	GND	IC ground
15	VREF	Reference voltage source output
16	SET	Output offset current set

Table 1: AM460 pinout

EXAMPLES OF POSSIBLE APPLICATIONS

- Conditioning signals referenced to ground (protected output stage, impedance converter etc.)

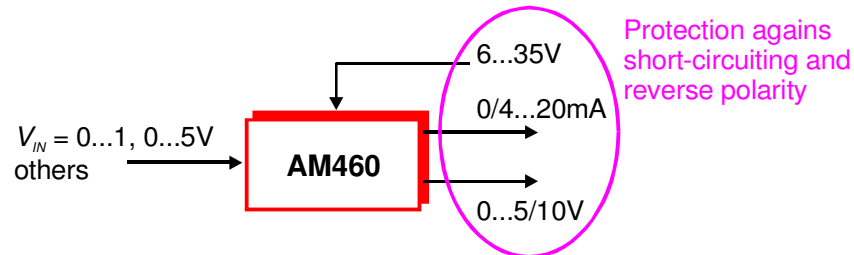

Figure 11: Application for input signals referenced to ground (protected output stage, impedance converter etc.)

- Complex configuration as a peripheral processor IC

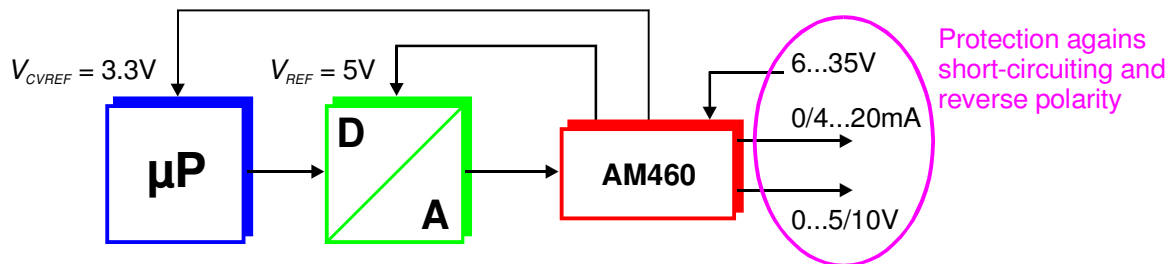

Figure 12: Complex configuration as a peripheral processor IC

- Conversion of a 0.5...4.5V sensor signal

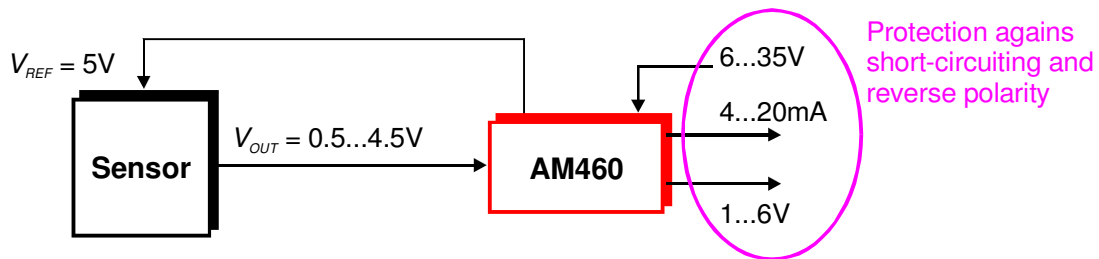

Figure 13: Conversion of a 0.5...4.5V sensor signal

DELIVERY

The AM460 converter and protector IC is available as the following packages:

- DIP16
- SO16(n) (maximum power dissipation $P_D = 300\text{mW}$)
- Dice on 5" blue foil

FURTHER READING

- [1] The Frame ASIC concept: <http://www.Frame-ASIC.de/>
- [2] The Analog Microelectronics GmbH website: <http://www.analogmicro.de/>

NOTES

Analog Microelectronics reserves the right to make amendments to any dimensions, technical data or other information herein without further notice.