

FEATURES

- Wide Supply Voltage Range: 6...35V
- Wide Operating Temperature Range: -40 °C...+85 °C
- Adjustable Voltage Reference: 4.5 to 10V
- Operational Amplifier Input: 0.5...4.5V, 0...5V, other
- Adjustable Offset Current
- Available as Three- (0/4...20mA) or Two-Wire Version (4...20mA)
- Adjustable Output Current Range
- Protection Against Reverse Polarity
- Protected Current Output

APPLICATIONS

- Sensor Interface
- Industrial Process Control
- Programmable Current Source
- Current Source Reference

BLOCK DIAGRAM

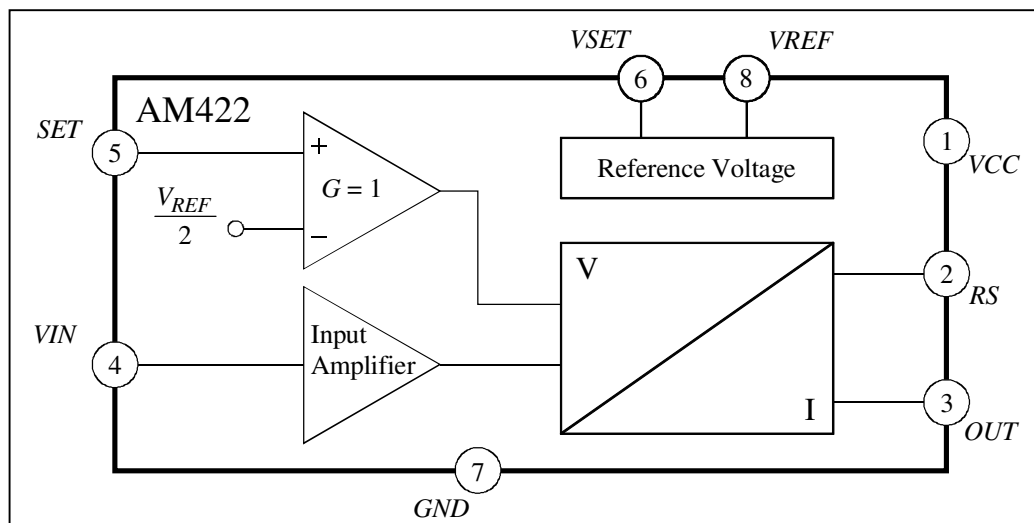

Figure 1

GENERAL DESCRIPTION

The AM422 is a low cost monolithic voltage-to-current converter specially designed for analog signal transmission. The AM422 is available in a 3- or 2-wire version, which allows applications with flexible input voltage ranges to be used for a standard output current. Output current range and current offset level are freely adjustable by external resistors. The IC consists of three basic sections: an operational amplifier input stage for single ended input signals (0.5-4.5V, 0-10V, or other), a programmable 4.5 to 10V reference for transducer excitation, and a current output, freely adjustable in a wide current range (4-20mA, 0-20mA, other). With the broad spectrum of possible input signals the AM422 is a flexible and multipurpose voltage-to-current converter for single ended transducers or voltage transmission.

DELIVERY

- DIL8 packages (samples)
- SOP8 packages
- Dice on 5" blue foil

ELECTRICAL SPECIFICATIONS

$T_{amb} = 25^{\circ}\text{C}$, $V_{CC} = 24\text{V}$, $V_{REF} = 5\text{V}$, $I_{REF} = 1\text{mA}$ (unless otherwise noted)

Parameter	Symbol	Conditions	Min.	Typ.	Max.	Unit
Voltage Range	V_{CC}		6		35	V
Quiescent Current	I_{CC}	$T_{amb} = -40\dots+85^{\circ}\text{C}$, $I_{REF} = 0\text{mA}$			1.5	mA
Temperature Specifications						
Operating	T_{amb}		-40		85	$^{\circ}\text{C}$
Storage	T_{st}		-55		125	$^{\circ}\text{C}$
Junction	T_J				150	$^{\circ}\text{C}$
Thermal Resistance	Θ_{ja}	DIL8 plastic package		110		$^{\circ}\text{C}/\text{W}$
	Θ_{ja}	SO8 plastic package		180		$^{\circ}\text{C}/\text{W}$
Voltage Reference						
Voltage	V_{REF}	$VSET$ not connected	4.75	5.00	5.25	V
	V_{REF}	$VSET = GND$, $V_{CC} \geq 11\text{V}$	9.5	10.0	10.5	V
Trim Range	V_{R10}		4.5		V_{R10}	V
Current	I_{REF}^*		0		10	mA
V_{REF} vs. Temperature	dV_{REF}/dT	$T_{amb} = -40\dots+85^{\circ}\text{C}$		± 90	± 140	ppm/ $^{\circ}\text{C}$
Line Regulation	dV_{REF}/dV	$V_{CC} = 6\text{V}\dots35\text{V}$		30	80	ppm/V
	dV_{REF}/dV	$V_{CC} = 6\text{V}\dots35\text{V}$, $I_{REF} \approx 5\text{mA}$		60	150	ppm/V
Load Regulation	dV_{REF}/dI			0.05	0.10	%/mA
	dV_{REF}/dI	$I_{REF} \approx 5\text{mA}$		0.06	0.15	%/mA
Load Capacitance	C_L		1.9	2.2	5.0	μF
Set Stage						
Internal Gain	G_{IA}			1		
Input Voltage	V_{SET}	$I_{SET} = 4\text{mA}$, $R_0 = 25\Omega$		2.6		V
Offset Voltage	V_{OS}			± 1	± 3	mV
V_{OS} vs. Temperature	dV_{OS}/dT			± 5		$\mu\text{V}/^{\circ}\text{C}$
Input Bias Current	I_B			8	20	nA
I_B vs. Temperature	dI_B/dT			6	15	pA/ $^{\circ}\text{C}$
Input Stage						
Internal Gain	G_{IN}			0.5		
Input Voltage	V_{IN}		0		1.15	V
Offset Voltage	V_{OS}			± 0.5	± 2.5	mV
V_{OS} vs. Temperature	dV_{OS}/dT			± 1.6	± 5	$\mu\text{V}/^{\circ}\text{C}$
Input Bias Current	I_B			8	20	nA
I_B vs. Temperature	dI_B/dT			7	18	pA/ $^{\circ}\text{C}$

Parameter	Symbol	Conditions	Min.	Typ.	Max.	Unit
V/I Converter						
Internal Gain	G_{VI}			1.00		
Trim Range		adjustable by R_0	0.75	1.00	1.25	
Voltage Range at R_0 FS	V_{R0FS}		400	500	580	mV
Offset Voltage	V_{OS}	$\beta_F \geq 100$		± 2	± 6	mV
V_{OS} vs. Temperature	dV_{OS}/dT	$\beta_F \geq 100$		± 7	± 20	$\mu V/^\circ C$
Output Offset Current	I_{OUTOS}	3-wire operation		-35	-50	μA
I_{OUTOS} vs. Temperature	dI_{OUTOS}/dT	3-wire operation		55	80	nA/ $^\circ C$
Output Offset Current	I_{OUTOS}	2-wire operation		14	22	μA
I_{OUTOS} vs. Temperature	dI_{OUTOS}/dT	2-wire operation		22	35	nA/ $^\circ C$
Output Control Current	I_{OUTC}	2-wire operation, $V_{R0}/100mV$		5		μA
I_{OUTC} vs. Temperature	dI_{OUTC}/dT	2-wire operation		-9		nA/ $^\circ C$
Output Voltage Range	V_{OUT}	$V_{OUT} = R_L I_{OUT}$, $V_{CC} < 16V$	0		$V_{CC} - 6$	V
	V_{OUT}	$V_{OUT} = R_L I_{OUT}$, $V_{CC} \geq 16V$	0		10	V
Output Current Range FS	I_{OUTFS}	$I_{OUT} = V_{R0}/R_0$, 3-wire operation		20		mA
Output Resistance	R_{OUT}		0.5	1.0		M Ω
Load Capacitance	C_L		0		500	nF
Protection Functions						
Voltage Limitation at R_0	V_{LIMR0}	$V_{R0} = V_{IN}/2$, $SET = V_{REF}/2$	580	635	690	mV
	V_{LIMR0}	$V_{IN} = 0$, $V_{R0} = V_{SET}/2 - V_{REF}/2$	580	640	700	mV
Temperature Limitation	T_{LIMIT}		110	130	150	$^\circ C$
Protection against reverse polarity		Ground vs. V_S vs. I_{OUT}			35	V
Current in case of reverse polarity		Ground = 35V, $V_S = I_{OUT} = 0$		3.8		mA
System Parameters						
Nonlinearity		ideal input		0.05	0.15	%FS

* In 2-wire operation a maximum current of $I_{OUTmin} - I_{CC}$ is valid
 Currents flowing into the IC are negative

BOUNDARY CONDITIONS

Parameter	Symbol	Conditions	Min.	Typ.	Max.	Unit
Sense Resistor	R_0	$I_{OUTFS} = 20mA$	20	25	29	Ω
	R_0	$c = 20mA/I_{OUTFS}$	$c \cdot 20$	$c \cdot 25$	$c \cdot 29$	Ω
Stabilisation Resistor	R_5	$I_{OUTFS} = 20mA$	35	40	45	Ω
	R_5	$c = 20mA/I_{OUTFS}$	$c \cdot 35$	$c \cdot 40$	$c \cdot 45$	Ω
Load Resistance	R_L	limitation only for 3-wire operation	0		500	Ω
Sum Offset Resistors	$R_3 + R_4$		20		200	k Ω
V_{REF} Capacitance	C_1		1.9	2.2	5.0	μF
Output Capacitance	C_2	only for 2-wire operation	90	100	250	nF
D_1 Breakdown Voltage	V_{BR}		35	50		V
T_1 Forward Current Gain	β_F		50	150		

FUNCTIONAL DIAGRAMS

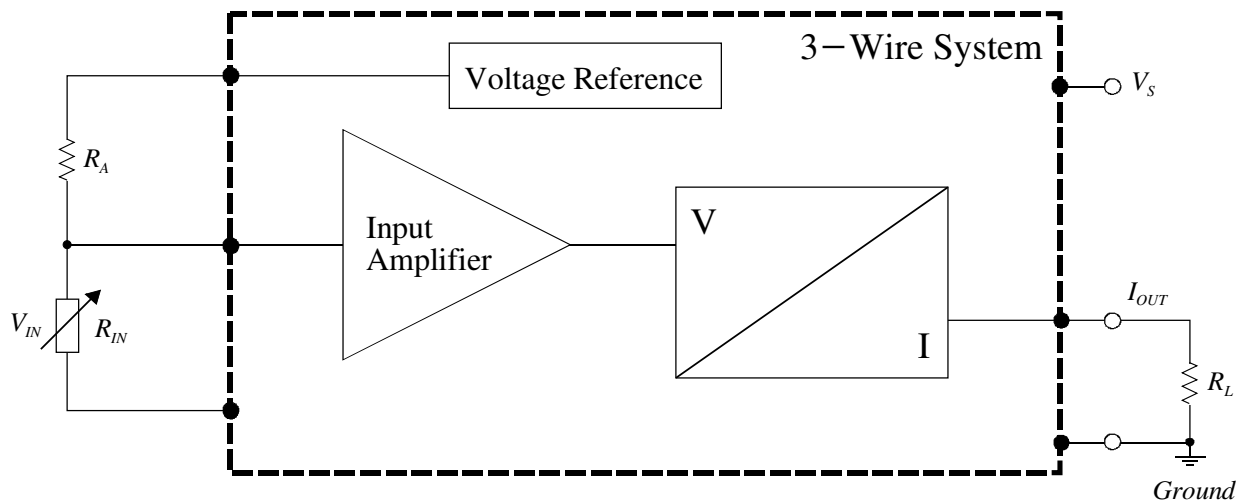

Figure 2

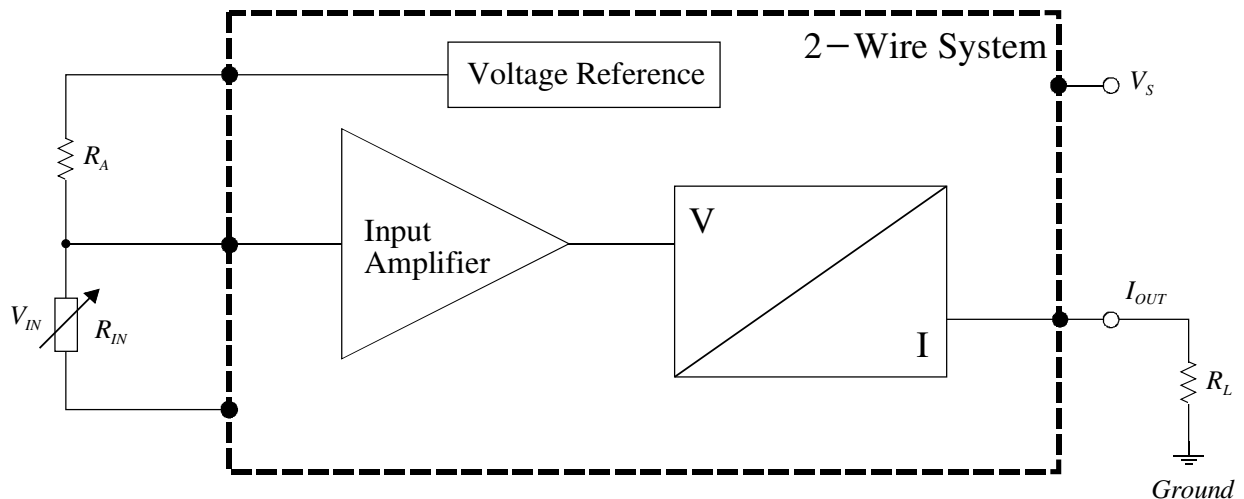

Figure 3

FUNCTIONAL DESCRIPTION

The IC AM422 is an integrated voltage-to-current converter for a broad spectrum of possible single ended input signals. With variations of a few external components the output current can be adjusted over a wide range. In addition to the resistors $R_0 - R_5$ and the capacitor C_1 (C_2), the circuitry needs only an output transistor T_1 and a diode D_1 . The external transistor decreases the power dissipation of the IC and the diode is protecting the transistor against reverse polarity. Typical values for the external components are listed in the *Application Notes*.

In principle the AM422 can be used as a two-wire or as a three-wire voltage-to-current interface. The schematic of the entire system for the three-wire output is demonstrated on Figure 2. The external reference point *Ground* has to be identical to the ground pin 7 (*GND*) and the IC supply voltage becomes $V_{CC} = V_S$. Opposed to this, the ground pin 7 in the two-wire mode (Figure 3) (*GND*)

has to be connected between the resistors R_5 and R_L . In this case the IC supply voltage V_{CC} depends on the voltage V_S and the load resistor R_L and can be calculated:

$$V_{CC} = V_S - I_{OUT} \cdot R_L \quad (1)$$

Basically the IC AM422 is composed of 3 functional sections as they shown in Figure 1:

1. An *operational amplifier input* which allows the adjustment of the output current range with the two external resistors R_1 and R_2 . With the variation of the resistors the input voltage range and the output current range can be set.
2. A *voltage controlled current output*, with a wide current range is adjustable with external resistors R_{SET} , R_3 and R_4 . The resistors fix the output offset current, which depends on the reference voltage and corresponds to a minimal output current. The output current I_{OUT} is supplied by the external transistor T_1 , driven by the output of the IC pin 3 (*OUT*).
3. A *programmable voltage reference* ($V_{SET} = N.C.$ or $V_{SET} = GND$) can be used as an excitation for constant voltage sensors or as supply for other external devices.

The output current is based on two partial currents: an adjustable offset current and a current relying on the input signal V_{IN} . The transfer function of the AM422 is then

$$I_{OUT}(V_{SET}, V_{IN}) = I_{SET}(V_{SET}) + I_{IN}(V_{IN}) \quad (2)$$

For the adjustment of the AM422 two cases have to be differentiated. For input voltage ranges without an offset voltage (0...5V, 0...10V) the adjustment of the output current range is as follows: The minimum output current has to be set with an input voltage $V_{IN} = 0V$. The output offset current becomes

$$I_{SET}(V_{IN} = 0) = \frac{1}{R_0} \cdot \left(V_{SET} - \frac{V_{REF}}{2} \right) = \frac{V_{REF}}{R_0} \cdot \frac{(R_4 + R_{SET}) - R_3}{2(R_3 + R_4 + R_{SET})} \quad (3)$$

With $R_3 = R_4$ and simplifications the set resistor R_{SET} is

$$R_{SET} \approx \frac{4 R_0 R_4 I_{SET}}{V_{REF}} \quad (4)$$

The output current range has to be set with the transfer function of the IC and can be calculated by

$$\Delta I_{OUT} = I_{OUTmax} - I_{SET} = \frac{V_{INmax}}{2 R_0} \left(\frac{R_2}{R_1 + R_2} \right) \quad (5)$$

The relationship of R_1/R_2 becomes

$$\frac{R_1}{R_2} = \frac{V_{INmax}}{2 R_0 (I_{OUTmax} - I_{SET})} - 1 \quad (6)$$

The adjustment of the IC using an input offset voltage (for example 0.5...4.5V) can be described as follows. For a desired change of the output current of ΔI_{OUT}

$$\Delta I_{OUT} = \frac{\Delta V_{PIN4}}{2 R_0} \quad \Rightarrow \quad \Delta V_{PIN4} = 2 R_0 \Delta I_{OUT} \quad (7)$$

the input voltage V_{IN} has to change to

$$\Delta V_{PIN4} = \Delta V_{IN} \left(\frac{R_2}{R_1 + R_2} \right) \quad (8)$$

With the value of the relationship of the resistors R_1 and R_2

$$\frac{R_1}{R_2} = \frac{\Delta V_{IN} - \Delta V_{PIN4}}{\Delta V_{PIN4}} \quad (9)$$

the additional offset current can be calculated as

$$I_{SET} = I_{OUTmin} - I_{INmin} = I_{OUTmin} - \frac{V_{INmin}}{2R_0} \left(\frac{R_2}{R_1 + R_2} \right) \quad (10)$$

The value of the set resistor can then be found using equation 4

In respect to the load resistor R_L , the value of the supply voltage V_S has to be considered with care. The following relation is generally valid (see equation 1):

$$V_S \geq I_{OUTmax} R_L + V_{CCmin} \quad (11)$$

The resulting operating range is indicated in Figure 4. Sample calculations and typical values for the external components are listed in the *Application Notes* (beginning page 8).

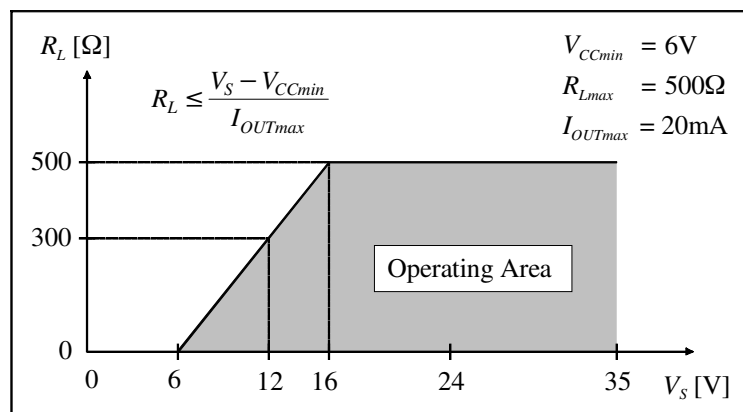

Figure 4

PINOUT

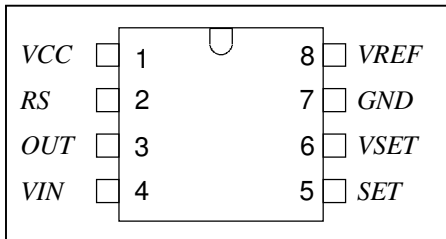

Figure 5

PIN	NAME	DESIGNATION
1	VCC	Supply Voltage
2	RS	Sense Resistor
3	OUT	Output
4	VIN	Voltage Input
5	SET	Set Voltage
6	VSET	Reference Voltage Select
7	GND	IC Ground
8	VREF	Reference Voltage Output

DELIVERY

The AM422 is available in 2– (AM422–2) or 3–wire version (AM422–1). The different versions are pin compatible. The AM422 is available as:

- 8 pin DIL packages (samples)
- SO 8 packages
- Dice on 5“ blue foil

PACKAGE DIMENSIONS SOP8

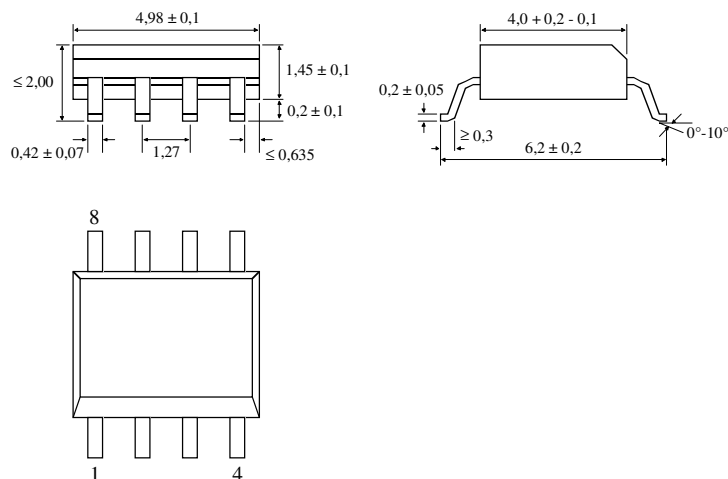

Figure 6

TYPICAL THREE-WIRE APPLICATION (0 – 5/10V)

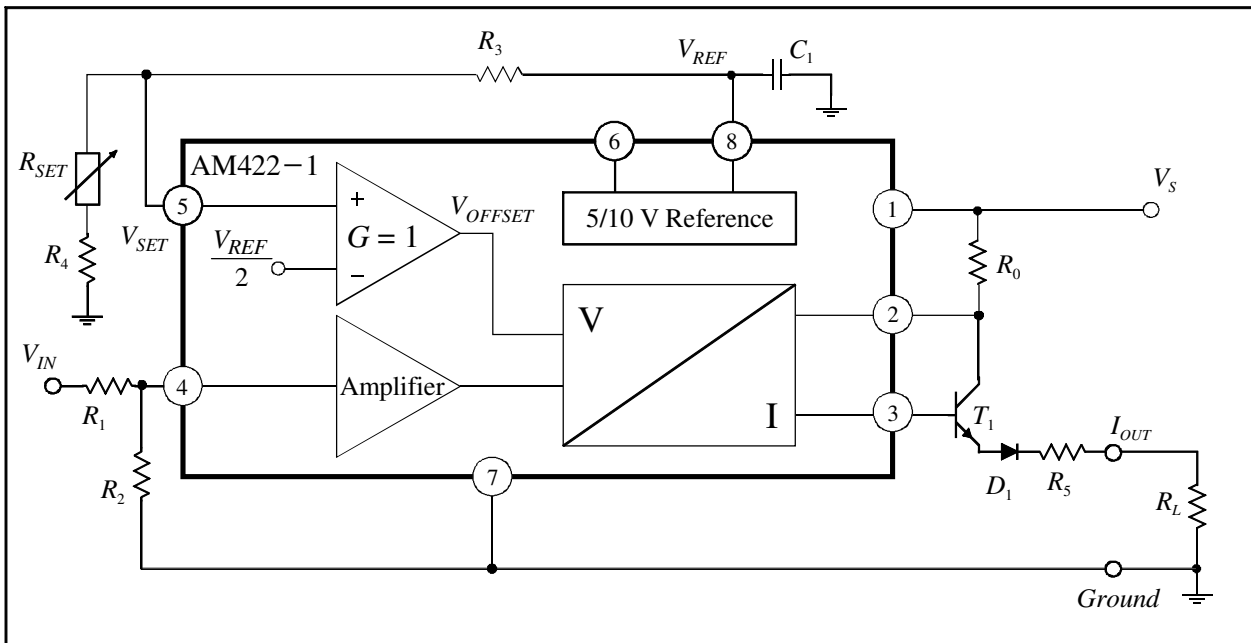

Figure 7

Used in a three-wire circuit (AM422-1) ground pin 7 (GND) is connected to Ground (Figure 7). The relationship of R_1/R_2 , using equation 2, becomes

$$\frac{R_1}{R_2} = \frac{V_{INmax}}{2 R_0 (I_{OUTmax} - I_{SET})} - 1$$

The current I_{SET} is used to set the output current offset and can be calculated by using equation 3

$$I_{SET} (V_{IN} = 0) = \frac{V_{REF}}{R_0} \cdot \frac{(R_4 + R_{SET}) - R_3}{2(R_3 + R_4 + R_{SET})}$$

With $R_3 = R_4$ the set resistor R_{SET} becomes (equation 4)

$$R_{SET} \approx \frac{4 R_0 R_4 I_{SET}}{V_{REF}}$$

Example 1: Output current range 4...20mA

In this case the values of the external devices ($V_{IN} = 0..5V$, $V_{REF} = 5V$) are as follows

$$R_0 = 25\Omega \quad R_3 = R_4 = 33k\Omega \quad R_{SET} \approx 2.64k\Omega \quad R_5 = 40\Omega$$

$$R_1/R_2 \approx 5.25 \quad R_L = 0..500\Omega \quad C_1 = 2.2\mu F$$

Example 2: Output current range 0...20mA

In this case the values of the external devices ($V_{IN} = 0..10V$, $V_{REF} = 5V$) are as follows

$$R_0 = 25\Omega \quad R_3 = R_4 = 33k\Omega \quad R_{SET} = 0\Omega \quad R_5 = 40\Omega$$

$$R_1/R_2 \approx 9 \quad R_L = 0..500\Omega \quad C_1 = 2.2\mu F$$

TYPICAL THREE-WIRE APPLICATION (0.5 – 4.5V)

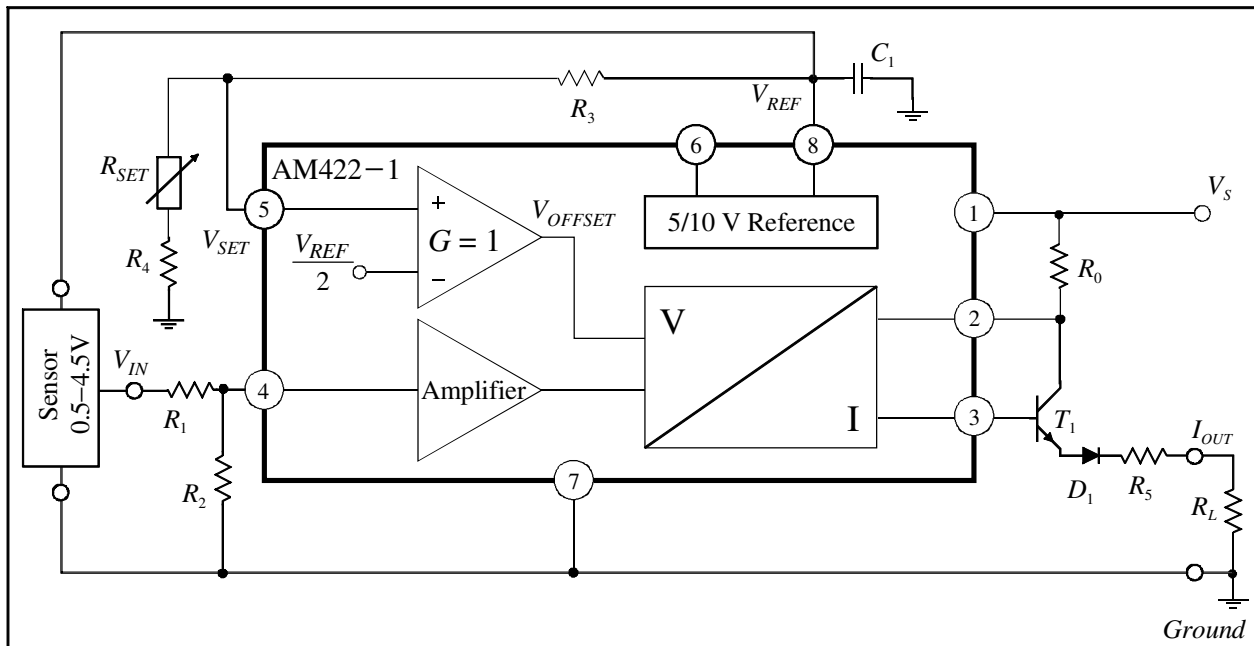

Figure 8

Example 3: Output current range $I_{OUT} = 4...20\text{mA}$, input voltage range $V_{IN} = 0.5...4.5\text{V}$

The transfer function of the output current I_{OUT} is (equation 2)

$$I_{OUT} = I_{SET} + I_{IN} = I_{SET} + \frac{V_{IN}}{2 R_0} \left(\frac{R_2}{R_1 + R_2} \right)$$

For the 0.5 to 4.5V application (Figure 8) a change of the input voltage from $\Delta V_{IN} = 4\text{V}$ should be displayed over a change of the output current $\Delta I_{OUT} = 16\text{mA}$.

With the voltage change at pin 4 ($\Delta V_{PIN4} = 800\text{mV}$, equation 7) the relationship of R_1/R_2 , using equation 8, becomes then

$$\frac{\Delta V_{PIN4}}{\Delta V_{IN}} = \frac{R_2}{R_1 + R_2} = \frac{800\text{mV}}{4\text{V}} \quad \Rightarrow \quad \frac{R_1}{R_2} = \frac{\Delta V_{IN} - \Delta V_{PIN4}}{\Delta V_{PIN4}} = 4$$

With that relation an offset current I_{SET} from

$$I_{SET} = I_{OUTmin} - I_{INmin} = I_{OUTmin} - 2\text{mA} = 2\text{mA}$$

has to be adjusted (equation 10). With $R_3 = R_4$ the set resistor R_{SET} can be calculated (equation 4)

$$R_{SET} \approx \frac{4 R_0 R_4 I_{SET}}{V_{REF}}$$

The values of the external devices than can be calculated as follows ($V_{REF} = 5\text{V}$)

$$R_0 = 25\Omega$$

$$R_3 = R_4 = 33\text{k}\Omega$$

$$R_{SET} \approx 1.32\text{k}\Omega$$

$$R_5 = 40\Omega$$

$$R_1/R_2 \approx 4$$

$$R_1 \approx 68\text{k}\Omega$$

$$R_2 \approx 18\text{k}\Omega$$

$$R_L = 0...500\Omega$$

$$C_1 = 2.2\mu\text{F}$$

TYPICAL TWO-WIRE APPLICATION (0 – 1V)

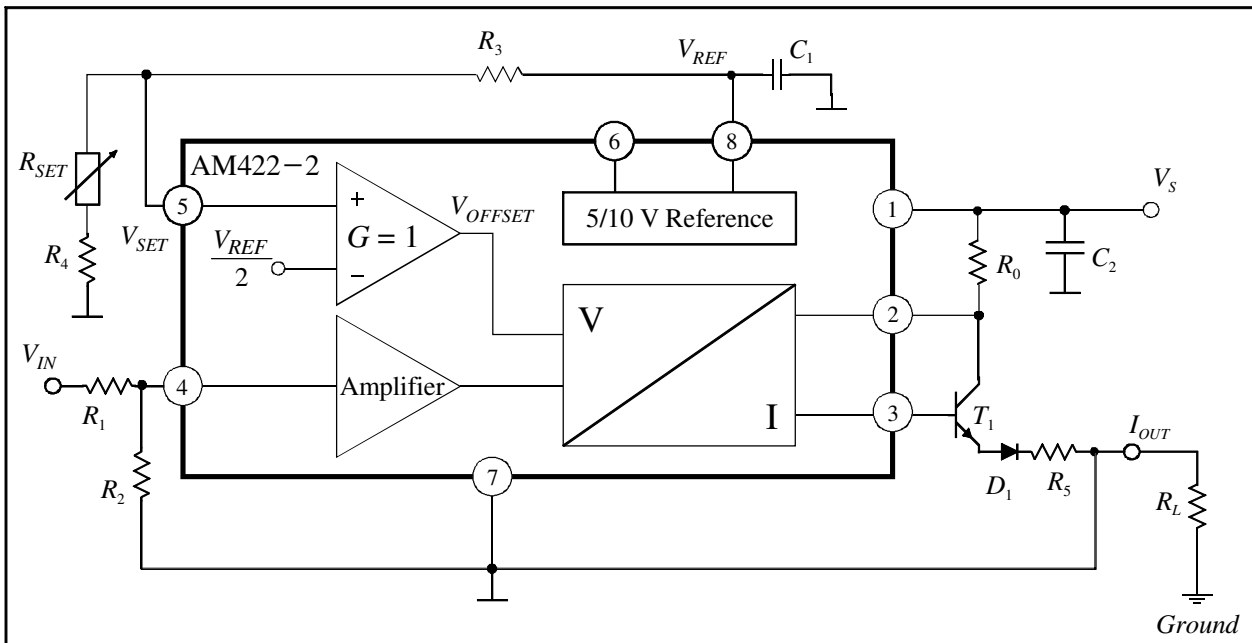

Figure 9

Used in a two-wire circuit (AM422-2) ground pin 7 (GND, \perp) is connected between R_5 and the load resistor (Figure 9). The relationship R_1/R_2 , using equation 2, becomes

$$\frac{R_1}{R_2} = \frac{V_{INmax}}{2 R_0 (I_{OUTmax} - I_{SET})} - 1$$

The current I_{SET} is used to set the output current offset and can be calculated by using equation 3

$$I_{SET}(V_{IN} = 0) = \frac{V_{REF}}{R_0} \cdot \frac{(R_4 + R_{SET}) - R_3}{2(R_3 + R_4 + R_{SET})}$$

With $R_3 = R_4$ the set resistor R_{SET} becomes (equation 4)

$$R_{SET} \approx \frac{4 R_0 R_4 I_{SET}}{V_{REF}}$$

Example 4: Output current range 4...20mA

In this case the values of the external devices ($V_{IN} = 0...1V$) are as follows

$$\begin{array}{llll} R_0 = 25\Omega & R_3 = R_4 = 33k\Omega & R_{SET} \approx 2.64k\Omega & R_5 = 40\Omega \\ R_1/R_2 \approx 0.25 & R_L = 0...500\Omega & C_1 = 2.2\mu F & C_2 = 100nF \end{array}$$

The information provided herein is believed to be reliable; however, Analog Microelectronics assumes no responsibility for inaccuracies or omissions. Analog Microelectronics assumes no responsibility for the use of this information, and all use of such information shall be entirely at the user's own risk. Prices and specifications are subject to change without notice. No patent rights or licences to any of the circuits described herein are implied or granted to any third party. Analog Microelectronics does not authorise or warrant any Analog Microelectronics product use in life support devices and/or systems.