

## FEATURES

- Wide Supply Voltage Range: 6...35V
- Wide Operating Temperature Range:  $-40^{\circ}\text{C}...+85^{\circ}\text{C}$
- Adjustable Reference Voltage Source: 4.5 to 10V
- Wide Common Mode Range Instrumentation Amplifier
- Adjustable Gain and Offset
- Two-Wire Output: 4...20mA
- Three-Wire Output: 0/4...20mA
- Adjustable Output Current Range
- Protection Against Reverse Polarity
- Current Shutdown with Overvoltage
- Shutdown with Excessive Temperature

## APPLICATIONS

- Industrial Process Control
- Sensor Signal Converter (e.g. pressure)
- Programmable Current Source

## GENERAL DESCRIPTION

AM402 is a monolithically integrated current converter which has been specially developed for the processing of differential bridge signals. AM402 is suitable for two- and three-wire applications and has four function blocks. A high-precision instrumentation amplifier (IA) serves as an input stage. A reference voltage source, which can be adjusted to values of between 4.5 and 10V, excites external components and a voltage-controlled current output stage converts the voltage signal. It is thus possible to generate output currents which correspond to the normal industrial standards (0/4–20mA,  $12 \pm 8\text{mA}$ ).

## DELIVERY

- DIL16 packages (samples)
- SO16(n) packages
- Dice on 5" blue foil

## BLOCK DIAGRAM

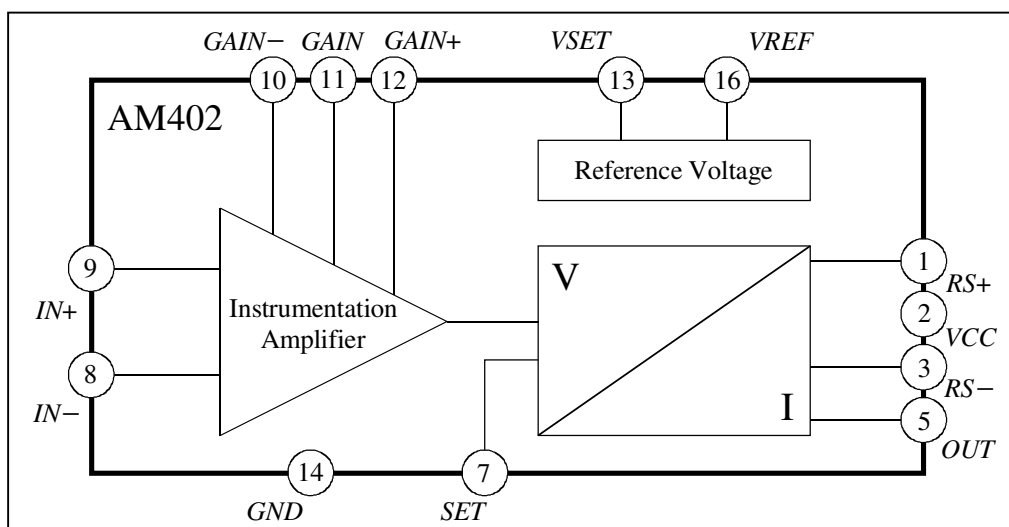

Figure 1

## ELECTRICAL SPECIFICATIONS

$T_{amb} = 25^{\circ}\text{C}$ ,  $V_{CC} = 24\text{V}$ ,  $V_{REF} = 5\text{V}$ ,  $I_{REF} = 1\text{mA}$  (unless otherwise noted)

Parameter	Symbol	Conditions	Min.	Typ.	Max.	Unit
Voltage Range	$V_{CC}$		6		35	V
Quiescent Current	$I_{CC}$	$T_{amb} = -40\dots+85^{\circ}\text{C}$ , $I_{REF} = 0\text{mA}$			1.5	mA
<b>Temperature Specifications</b>						
Operating	$T_{amb}$		-40		85	$^{\circ}\text{C}$
Storage	$T_{st}$		-55		125	$^{\circ}\text{C}$
Junction	$T_J$				150	$^{\circ}\text{C}$
Thermal Resistance	$\Theta_{ja}$	DIL16 plastic package		70		$^{\circ}\text{C}/\text{W}$
	$\Theta_{ja}$	SO16 narrow plastic package		140		$^{\circ}\text{C}/\text{W}$
<b>Voltage Reference</b>						
Voltage	$V_{REF}$	$V_{SET}$ not connected	4.75	5.00	5.25	V
	$V_{REF}$	$V_{SET} = GND$ , $V_{CC} \geq 11\text{V}$	9.5	10.0	10.5	V
Trim Range	$V_{R10}$		4.5		$V_{R10}$	V
Current	$I_{REF}^*$		0		10	mA
$V_{REF}$ vs. Temperature	$dV_{REF}/dT$	$T_{amb} = -40\dots+85^{\circ}\text{C}$		$\pm 90$	$\pm 140$	ppm/ $^{\circ}\text{C}$
Line Regulation	$dV_{REF}/dV$	$V_{CC} = 6\text{V}\dots35\text{V}$		30	80	ppm/V
	$dV_{REF}/dV$	$V_{CC} = 6\text{V}\dots35\text{V}$ , $I_{REF} \approx 5\text{mA}$		60	150	ppm/V
Load Regulation	$dV_{REF}/dI$			0.05	0.10	%/mA
	$dV_{REF}/dI$	$I_{REF} \approx 5\text{mA}$		0.06	0.15	%/mA
Load Capacitance	$C_L$		1.9	2.2	5.0	$\mu\text{F}$
<b>SET Stage</b>						
Internal Gain	$G_{SET}$		0	0.5		
Input Voltage	$V_{SET}$		0		1.15	V
Offset Voltage	$V_{OS}$			$\pm 0.5$	$\pm 2.5$	mV
$V_{OS}$ vs. Temperature	$dV_{OS}/dT$			$\pm 1.6$	$\pm 5$	$\mu\text{V}/^{\circ}\text{C}$
Input Bias Current	$I_B$			8	20	nA
$I_B$ vs. Temperature	$dI_B/dT$			7	18	pA/ $^{\circ}\text{C}$
<b>Instrumentation Amplifier</b>						
Adjustable Gain	$G_{IA}$		1	5		
Differential Input Voltage Range	$V_{IN}$	$SET = GND$	0		$580/G_{IA}$	mV
Common Mode Input Range	$CMIR$	$V_{CC} < 9\text{V}$	1.5		$V_{CC} - 3$	V
	$CMIR$	$V_{CC} \geq 9\text{V}$	1.5		6.0	V
Common Mode Rejection Ratio	$CMRR$		80	90		dB
Power Supply Rejection Ratio	$PSRR$		80	90		dB
Offset Voltage	$V_{OS}$			$\pm 1$	$\pm 3$	mV
$V_{OS}$ vs. Temperature	$dV_{OS}/dT$			$\pm 5$		$\mu\text{V}/^{\circ}\text{C}$
Input Bias Current	$I_B$			8	20	nA
$I_B$ vs. Temperature	$dI_B/dT$			6	15	pA/ $^{\circ}\text{C}$
Input Offset Current	$I_{OS}$			0.2		nA
$I_{OS}$ vs. Temperature	$dI_{OS}/dT$			0.8		pA/ $^{\circ}\text{C}$
Output Voltage Range FS	$V_{OUTFS}$	$V_{OUTFS} = V_{GAIN+} - V_{GAIN-}$	400	500	580	mV
Load Capacitance	$C_L$				250	pF

Parameter	Symbol	Conditions	Min.	Typ.	Max.	Unit
<b>V/I Converter</b>						
Internal Gain	$G_{VI}$			1.00		
Trim Range		adjustable by $R_0$	0.75	1.00	1.25	
Voltage Range at $R_0$ FS	$V_{R0FS}$		400	500	580	mV
Offset Voltage	$V_{OS}$	$\beta_F \geq 100$		$\pm 2$	$\pm 6$	mV
$V_{OS}$ vs. Temperature	$dV_{OS}/dT$	$\beta_F \geq 100$		$\pm 7$	$\pm 20$	$\mu V/^\circ C$
Output Offset Current	$I_{OUTOS}$	3-wire operation		-35	-50	$\mu A$
$I_{OUTOS}$ vs. Temperature	$dI_{OUTOS}/dT$	3-wire operation		55	80	nA/ $^\circ C$
Output Offset Current	$I_{OUTOS}$	2-wire operation		14	22	$\mu A$
$I_{OUTOS}$ vs. Temperature	$dI_{OUTOS}/dT$	2-wire operation		22	35	nA/ $^\circ C$
Output Control Current	$I_{OUTC}$	2-wire operation, $V_{R0}/100mV$		5		$\mu A$
$I_{OUTC}$ vs. Temperature	$dI_{OUTC}/dT$	2-wire operation		-9		nA/ $^\circ C$
Output Voltage Range	$V_{OUT}$	$V_{OUT} = R_L I_{OUT}$ , $V_{CC} < 16V$	0		$V_{CC} - 6$	V
	$V_{OUT}$	$V_{OUT} = R_L I_{OUT}$ , $V_{CC} \geq 16V$	0		10	V
Output Current Range FS	$I_{OUTFS}$	$I_{OUT} = V_{R0}/R_0$ , 3-wire operation		20		mA
Output Resistance	$R_{OUT}$		0.5	1.0		M $\Omega$
Load Capacitance	$C_L$		0		500	nF
<b>Protection Functions</b>						
Voltage Limitation at $R_0$	$V_{LIMR0}$	$V_{R0} = V_{IN} G_{IA}$ , $SET = GND$	580	640	700	mV
	$V_{LIMR0}$	$V_{IN} = 0$ , $V_{R0} = V_{SET}/2$	580	635	690	mV
Temperature Limitation	$T_{LIMIT}$		110	130	150	$^\circ C$
Protection against reverse polarity		Ground vs. $V_S$ vs. $I_{OUT}$			35	V
Current in case of reverse polarity		Ground = 35V, $V_S = I_{OUT} = 0$		3.8		mA
<b>System Parameters</b>						
Nonlinearity		ideal input		0.05	0.15	%FS

\* In 2-wire operation a maximum current of  $I_{OUTmin} - I_{CC}$  is valid  
 Currents flowing into the IC are negative

## BOUNDARY CONDITIONS

Parameter	Symbol	Conditions	Min.	Typ.	Max.	Unit
Sense Resistor	$R_0$	$I_{OUTFS} = 20mA$	20	25	29	$\Omega$
	$R_0$	$c = 20mA/I_{OUTFS}$	$c \cdot 20$	$c \cdot 25$	$c \cdot 29$	$\Omega$
Stabilisation Resistor	$R_5$	$I_{OUTFS} = 20mA$	35	40	45	$\Omega$
	$R_5$	$c = 20mA/I_{OUTFS}$	$c \cdot 35$	$c \cdot 40$	$c \cdot 45$	$\Omega$
Load Resistance	$R_L$	limitation only for 3-wire operation	0		500	$\Omega$
Sum Gain Resistors	$R_1 + R_2$		25		50	k $\Omega$
Sum Offset Resistors	$R_3 + R_4$		20		200	k $\Omega$
$V_{REF}$ Capacitance	$C_1$		1.9	2.2	5.0	$\mu F$
Output Capacitance	$C_2$	only for 2-wire operation	90	100	250	nF
$D_1$ Breakdown Voltage	$V_{BR}$		35	50		V
$T_1$ Forward Current Gain	$\beta_F$		50	150		

## FUNCTIONAL DIAGRAMS

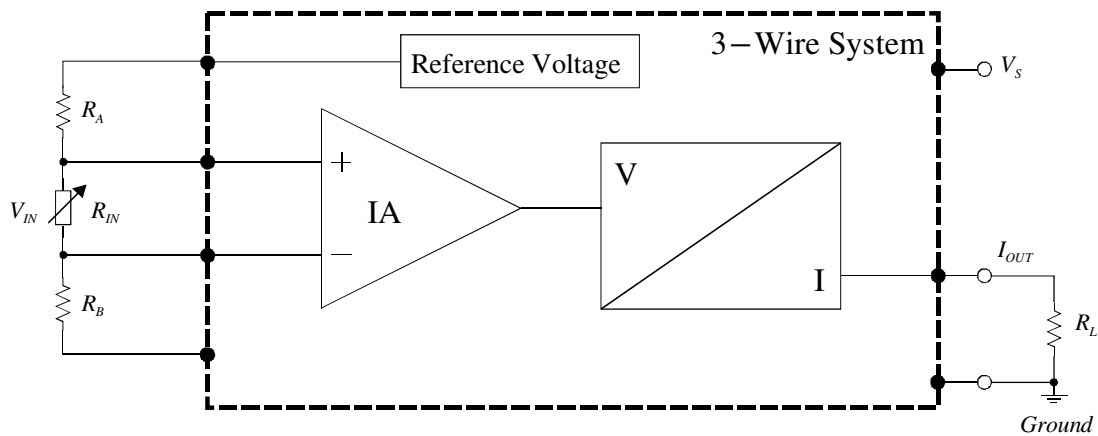

Figure 2

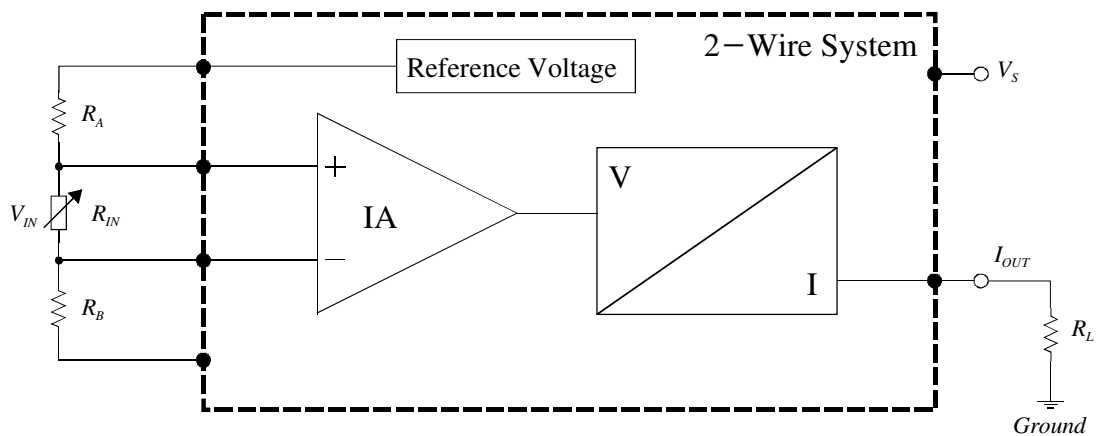

Figure 3

## FUNCTIONAL DESCRIPTION

AM402 is a monolithically integrated current converter which has been specially developed for the processing of differential bridge signals. By varying a few external components, the output current can be set to various values within a wide range. Only an external output transistor  $T_1$  and a diode  $D_1$  are needed (See Figure 7 and Figure 8) in addition to the resistors  $R_0 - R_5$  and the capacitor  $C_1$  ( $C_2$ ). The external transistor decreases the power dissipation of the IC and the diode protects the transistor against reverse polarity. The maximum power dissipation of the components must be taken into consideration when selecting the transistor and diode. Typical values for the external components are given in the following *Description of Applications*.

AM402 can principally be used in the implementation of two- and three-wire systems for industrial applications. A schematic diagram illustrates a three-wire system in Figure 2. Here, the differential input voltage ( $V_{IN}$ ) is shown as a variable resistor. The external reference point *Ground* is identical to the ground of the IC (*GND*) and the supply voltage of the IC matches that of the system:  $V_{CC} = V_S$ . In two-wire configurations, however (Figure 3), the ground of the IC (*GND*) is connected between resistors  $R_5$  and  $R_L$ . In this instance, the supply voltage of the IC ( $V_{CC}$ ) is dependent on the supply voltage of the system ( $V_S$ ) and the value of the load resistor ( $R_L$ ). It can be calculated using the equation:

$$V_{CC} = V_S - I_{OUT} \cdot R_L$$

AM402 is basically made up of three function blocks (see Figure 1):

1. The amplification of the high-precision *instrumentation amplifier* as the input stage is adjustable and thus makes applications for a number of input signals and sensors possible. Gain  $G_{IA}$  is set via the two external resistors  $R_1$  and  $R_2$ . When selecting the resistors, the sum of  $R_1 + R_2$  given in the *Boundary Conditions* must be heeded. When configuring the instrumentation amplifier, the user should ensure that the input signal has the correct polarity.
2. At the *voltage-controlled current output* an offset current can be set at the output with the help of the internal voltage reference across external resistors  $R_3$  and  $R_4$  (see the *Description of Applications*, beginning on page 7). Output current  $I_{OUT}$  is provided by external transistor  $T_1$  which is driven by the output ( $I_{OUT}$ ) of the IC. One particular feature of AM402 is that the output current is switched-off if overvoltage occurs on the input side of the device. Another safety feature included in AM402 is the integrated power-down function with excessive temperature. With this, the output current is switched off if the IC gets too warm.
3. The *adjustable reference voltage source* supplies sensors or other external components with voltage of 5 or 10V ( $V_{SET} = N.C.$  or  $V_{SET} = GND$ ). Additionally, any voltage value between 4.5 and 10V can be set via an external voltage divider. Please note, that Capacitor  $C_1$  (ceramic) must also be connected even when the voltage reference is not used.

### Initial Operation of AM402

To compensate the offset of the output current for the first time, the input must be short-circuited ( $V_{IN} = 0$ ). In doing so, it should be ensured that the input pins of the instrumentation amplifier have the voltage potentials given in the *Electrical Specifications* (input voltage range). The short circuit at the input produces an output current  $I_{OUT} = I_{SET}$  with

$$I_{SET} (V_{IN} = 0) = \frac{V_{REF}}{2R_0} \cdot \frac{R_4}{R_3 + R_4}$$

The adjustment of the output current range depends on the choice of external resistors  $R_1$  and  $R_2$ . The maximum output current is defined by the general transfer function of the IC. The following equation is given for the output current  $I_{OUT}$ :

$$I_{OUT} = V_{IN} \frac{G_{IA}}{R_0} + I_{SET}$$

The gain factor of the instrumentation amplifier  $G_{IA} = 1 + R_1/R_2$  is determined by the input voltage  $V_{IN}$  and the maximum output current  $I_{OUTmax}$ .

The minimum supply voltage is dependent on the value of the reference voltage. The following applies:

$$V_{CC} \geq V_{REF} + 1V.$$

The choice of supply voltage  $V_S$  also depends on the load resistor  $R_L$  used by the application. The following inequation determines the minimum supply voltage:

$$V_S \geq I_{OUTmax} R_L + V_{CCmin}.$$

The resulting operating range is given in Figure 4. Example calculations and typical values for the external components can be found in the example application shown in the *Applications* from page 7 onwards.

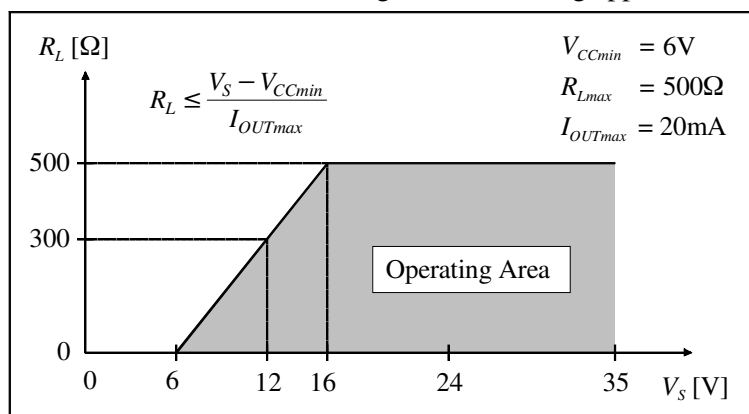

Figure 4

## PINOUT

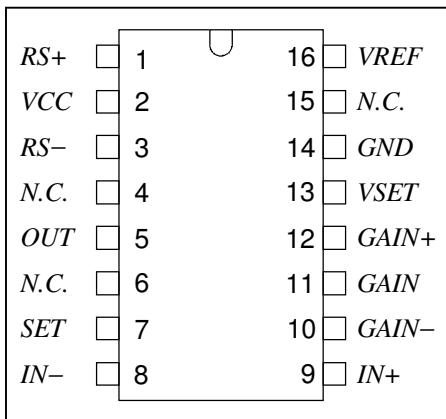

Figure 5

PIN	NAME	DESIGNATION
1	RS+	Sense Resistor +
2	VCC	Supply Voltage
3	RS-	Sense Resistor -
4	N.C.	Not Connected
5	OUT	Output
6	N.C.	Not Connected
7	SET	Set Output Current
8	IN-	Input Negative
9	IN+	Input Positive
10	GAIN-	Gain Adjustment
11	GAIN	Gain Adjustment
12	GAIN+	Gain Adjustment
13	VSET	Reference Voltage Select
14	GND	IC Ground
15	N.C.	Not Connected
16	VREF	Reference Voltage Output

## DELIVERY

The AM402 is available in version:

- 16 pin DIL packages (samples)
- SO 16 (n) packages (maximum power dissipation  $P_D = 300\text{mW}$ )
- Dice on 5" blue foil

## PACKAGE DIMENSIONS SO16 (n)

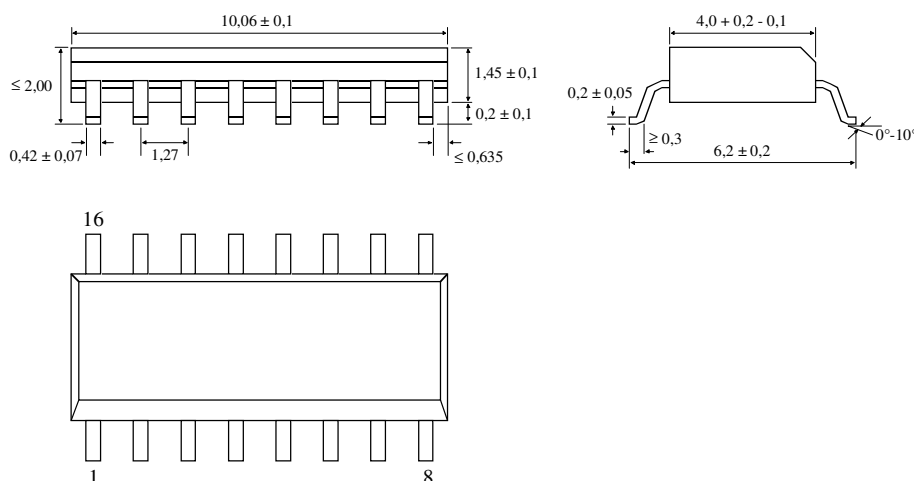

Figure 6

## TYPICAL THREE-WIRE APPLICATION (0/4–20mA)

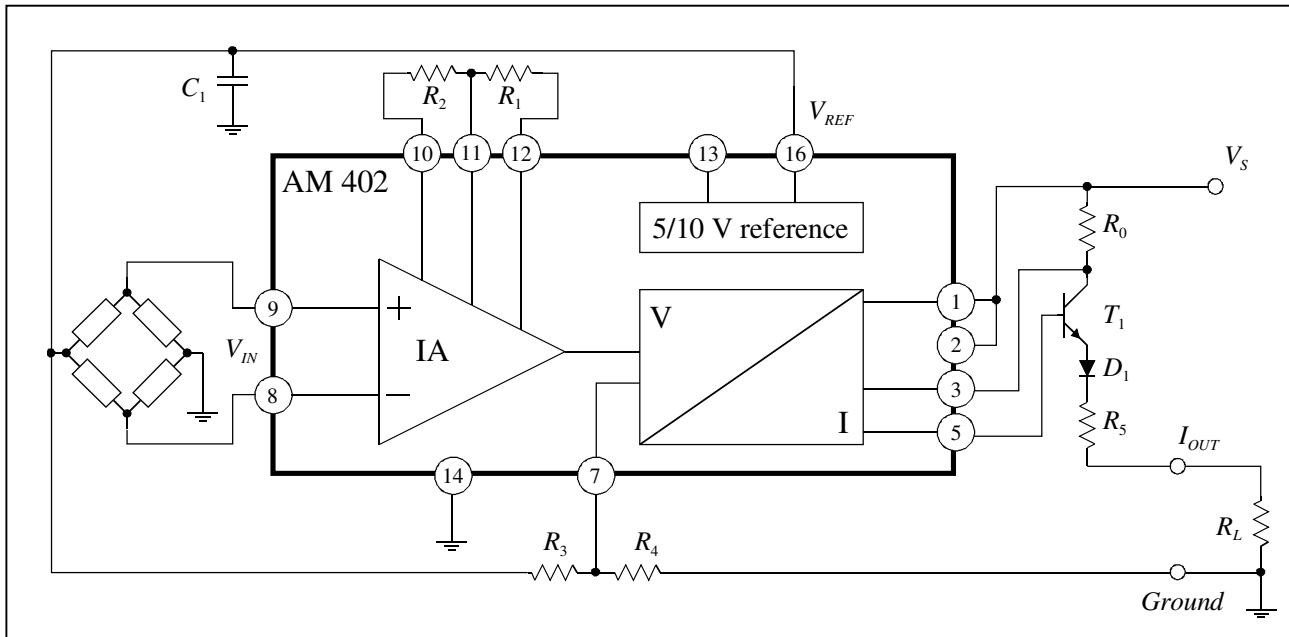

Figure 7

Used in a three-wire circuit, pin 2 ( $V_{CC}$ ) is connected to pin 1 ( $RS+$ ) and ground pin 14 ( $GND$ ) is connected to  $Ground$  (Figure 7). The Gain  $G_{IA}$  is adjusted by external resistors  $R_1$  and  $R_2$  and can be calculated by

$$G_{IA} = 1 + R_1/R_2 \Rightarrow R_1/R_2 = G_{IA} - 1$$

Hence, the transfer-function of the output current  $I_{OUT}$  becomes

$$I_{OUT} = V_{IN} G_{IA} / R_0 + I_{SET}$$

with the current  $I_{SET}$  adjusted by external resistors  $R_3$  and  $R_4$ .

$$I_{SET} = \frac{V_{REF}}{2 R_0} \cdot \frac{R_4}{R_3 + R_4} \Rightarrow \frac{R_3}{R_4} = \frac{V_{REF}}{2 R_0 I_{SET}} - 1$$

The supply voltage must be chosen with respect to the load resistor  $R_L$  described by the following equation

$$V_S \geq I_{OUTmax} R_L + 6V$$

### Example 1: Output current range 4...20mA

The values of the external devices ( $V_{IN} = 0...50mV$ ,  $V_{REF} = 5V$ ,  $G_{IA} = 8$ ) are as follows

$$\begin{array}{llll} R_0 = 25\Omega & R_1 = 33k\Omega & R_2 = 4.7k\Omega & R_3 = 100k\Omega \\ R_4 = 0...5k\Omega & R_5 = 40\Omega & R_L = 0...500\Omega & C_1 = 2.2\mu F \end{array}$$

### Example 2: Output current range 0...20mA

The values of the external devices ( $V_{IN} = 0...250mV$ ,  $V_{REF} = 5V$ ,  $G_{IA} = 2$ ) are as follows

$$\begin{array}{llll} R_0 = 25\Omega & R_1 = 22k\Omega & R_2 = 22k\Omega & R_5 = 40\Omega \\ R_3, R_4 \text{ not used (SET = GND)} & & R_L = 0...500\Omega & C_1 = 2.2\mu F \end{array}$$

## TYPICAL TWO-WIRE APPLICATION (4–20mA)

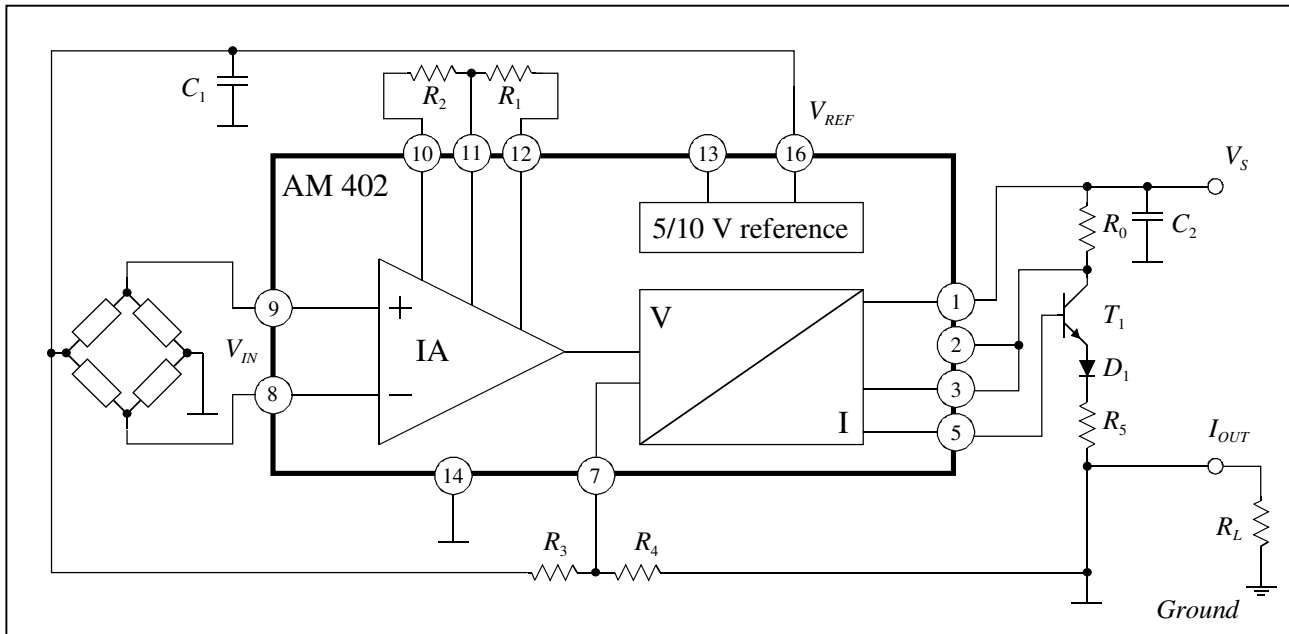

**Figure 8**

Used in a two-wire circuit, pin 2 ( $V_{CC}$ ) is connected to pin 3 ( $RS-$ ) and ground pin 14 ( $GND, \perp$ ) is connected to  $R_L$  (Figure 8). The Gain  $G_{IA}$  is adjusted by external resistors  $R_1$  and  $R_2$  and can be calculated by

$$G_{IA} = 1 + R_1/R_2 \Rightarrow R_1/R_2 = G_{IA} - 1$$

Hence, the transfer-function of the output current  $I_{OUT}$  becomes

$$I_{OUT} = V_{IN} G_{IA} / R_0 + I_{SET}$$

with the current  $I_{SET}$  adjusted by external resistors  $R_3$  and  $R_4$ .

$$I_{SET} = \frac{V_{REF}}{2 R_0} \cdot \frac{R_4}{R_3 + R_4} \Rightarrow \frac{R_3}{R_4} = \frac{V_{REF}}{2 R_0 I_{SET}} - 1$$

The supply voltage must be chosen with respect to the load resistor  $R_L$  described by the following equation

$$V_S \geq I_{OUTmax} R_L + 6V$$

### Example 3: Output current range 4...20mA

The values of the external devices ( $V_{IN} = 0..200mV$ ,  $V_{REF} = 5V$ ,  $G_{IA} = 2$ ) are as follows

$R_0 = 25\Omega$	$R_1 = 22k\Omega$	$R_2 = 22k\Omega$	$R_3 = 100k\Omega$	$R_4 = 0..5k\Omega$
$R_5 = 40\Omega$	$R_L = 0..500\Omega$	$C_1 = 2.2\mu F$	$C_2 = 100nF$	

The information provided herein is believed to be reliable; however, Analog Microelectronics assumes no responsibility for inaccuracies or omissions. Analog Microelectronics assumes no responsibility for the use of this information, and all use of such information shall be entirely at the user's own risk. Prices and specifications are subject to change without notice. No patent rights or licences to any of the circuits described herein are implied or granted to any third party. Analog Microelectronics does not authorise or warrant any Analog Microelectronics product use in life support devices and/or systems.