

UNIVERSAL AMPLIFIER IC

AM400

PRINCIPLE FUNCTION

Amplification and conversion of differential input voltages or those referenced to ground to industrial standard current (0/4...20mA) or voltage signals (e.g. 0...5/10V, 0.5...4.5V)

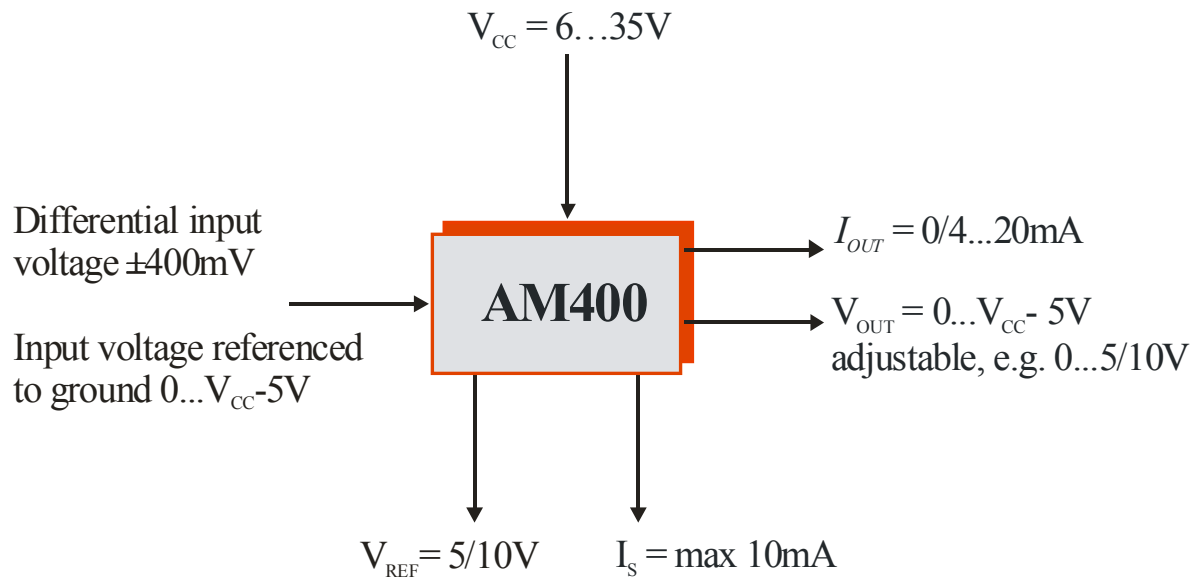

TYPICAL APPLICATIONS

- Transducer for sensor applications
- Analog industrial output stage for microprocessor applications
- Modular signal conditioning with digital correction (Frame ASIC [1])
- Protected output stage power network
- Impedance converter

UNIVERSAL AMPLIFIER IC

AM400

CONTENTS

FEATURES	3
GENERAL DESCRIPTION	3
BLOCK DIAGRAM	3
ELECTRICAL SPECIFICATIONS	4
BOUNDARY CONDITIONS	7
DETAILED DESCRIPTION OF FUNCTIONS	7
OPERATING AM400	10
General information on 2- and 3-wire applications	10
Setting the voltage gain using the voltage output	11
Setting the output current range and compensating for the offset using the current output	11
Selecting the supply voltage	11
POINTS TO NOTE: INITIAL OPERATION OF AM400	12
APPLICATIONS	13
1) Typical 3-wire application with a differential input signal	13
2) Typical 3-wire application with an input signal referenced to ground	14
3) Typical 2-wire application with a differential input signal	15
4) Application for the 16-pole version of AM400 (3-wire application)	17
BLOCK DIAGRAM, 20-POLE PINOUT AND DICE	18
BLOCK DIAGRAM AND 16-POLE PINOUT	19
EXAMPLE APPLICATIONS	20
DELIVERY	21
PACKAGE DIMENSIONS	21
FURTHER READING	21

UNIVERSAL AMPLIFIER IC

AM400

FEATURES

- Instrumentation amplifier with a wide input voltage range
- Adjustable gain and offset
- Parallel analog voltage (e.g. 0...5/10V) and current (e.g. 0/4...20mA) output
- Two and three-wire operation
- Protection against reverse polarity and short-circuiting
- Output current limitation
- Integrated current source
- Adjustable integrated reference voltage source: 4.5 to 10V
- Supply voltage: 6...35V
- Wide operating temperature range: -40°C...+85°C
- Individually accessible function modules
- RoHS compliant
- Two package variants: SOP and SSOP

GENERAL DESCRIPTION

AM400 is a monolithically integrated measuring amplifier with a parallel current and voltage output which has been specifically developed for the processing of differential input signals. AM400 consists of various functional modules. It contains both an instrumentation amplifier input and an input for signals referenced to ground. One particular feature of the device is the current and voltage outputs which can be used simultaneously. The output ranges can be selected using external resistors, enabling AM400 to be configured for the analog 0/4...20mA and 0...5/10V industrial power network, for example. Integrated voltage and current sources covering a wide range of values can be used to power external components.

AM400 has been designed for ideal use with external processors (such as a microprocessor, for example, for signal correction [1]).

BLOCK DIAGRAM

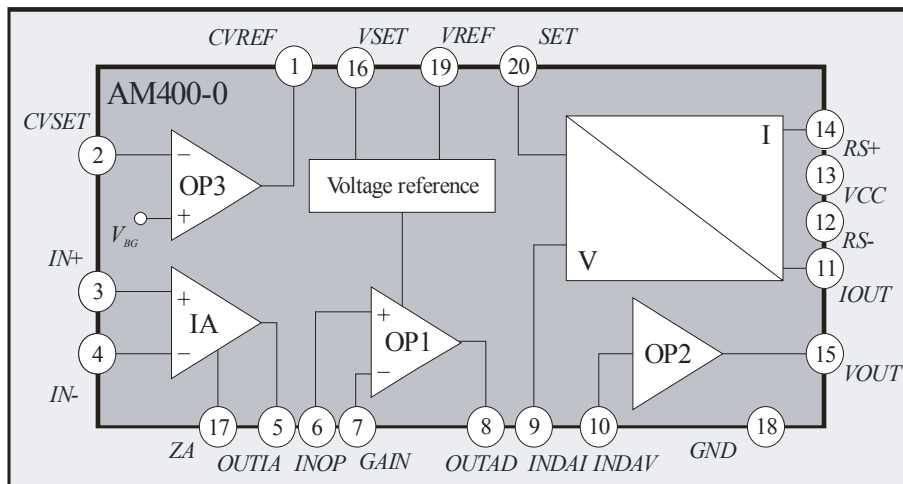

Figure 1: Block diagram of AM400 in the 20-pole version

UNIVERSAL AMPLIFIER IC

AM400

ELECTRICAL SPECIFICATIONS

$T_{amb} = 25^{\circ}\text{C}$, $V_{CC} = 24\text{V}$, $V_{REF} = 5\text{V}$, $I_{REF} = 1\text{mA}$ (unless otherwise stated); currents flowing into the IC are negative.

Parameter	Symbol	Conditions	Min.	Typ.	Max.	Unit
Supply Voltage Range	V_{CC}		6		35	V
Quiescent Current	I_{CC}	$T_{amb} = -40\dots+85^{\circ}\text{C}$, $I_{REF} = 0\text{mA}$			1.5	mA
Temperature Specifications						
Operating	T_{amb}		-40		85	$^{\circ}\text{C}$
Storage	T_{st}		-55		125	$^{\circ}\text{C}$
Junction	T_J				150	$^{\circ}\text{C}$
Voltage Reference						
Voltage	V_{REF}	V_{SET} not connected	4.75	5.00	5.25	V
	V_{REF}^{**}	$V_{SET} = GND$, $V_{CC} \geq 11\text{V}$	9.5	10.0	10.5	V
Trim Range	V_{R10}^{**}		4.5		V_{R10}	V
Current	I_{REF}^*		0		10.0	mA
V_{REF} vs. Temperature	dV_{REF}/dT	$T_{amb} = -40\dots+85^{\circ}\text{C}$		± 90	± 140	ppm/ $^{\circ}\text{C}$
Line Regulation	dV_{REF}/dV	$V_{CC} = 6\text{V}\dots35\text{V}$		30	80	ppm/V
	dV_{REF}/dV	$V_{CC} = 6\text{V}\dots35\text{V}$, $I_{REF} \approx 5\text{mA}$		60	150	ppm/V
Load Regulation	dV_{REF}/dI			0.05	0.10	%/mA
	dV_{REF}/dI	$I_{REF} \approx 5\text{mA}$		0.06	0.15	%/mA
Load Capacitance	C_L		1.9	2.2	5.0	μF
Current/Voltage Source OP3						
Internal Reference	V_{BG}		1.20	1.27	1.35	V
V_{BG} vs. Temperature	dV_{BG}/dT	$T_{amb} = -40\dots+85^{\circ}\text{C}$		± 60	± 140	ppm/ $^{\circ}\text{C}$
Current Source: $I_{CV} = V_{BG}/R_{EXT}$						
Adjustable Current Range	I_{CV}^*		0		10	mA
Output Voltage	V_{CV}	$V_{CC} < 19\text{V}$	V_{BG}		$V_{CC} - 4$	V
	V_{CV}	$V_{CC} \geq 19\text{V}$	V_{BG}		15	V
Voltage Source: $V_{CV} = V_{BG}(R_{EXT1} + R_{EXT2}) / R_{EXT2}$						
Adjustable Voltage Range	V_{CV}	$V_{CC} < 19\text{V}$	0.4		$V_{CC} - 4$	V
	V_{CV}	$V_{CC} \geq 19\text{V}$	0.4		15	V
Output Current	I_{CV}^*	Source			10	mA
	I_{CV}	Sink			-100	μA
Load Capacitance	C_L	Source mode	0	1	10	nF
Instrumentation Amplifier						
Internal Gain	G_{IA}		4.9	5	5.1	
Differential Input Voltage Range	V_{IN}		0		± 400	mV
Common Mode Input Range	$CMIR$	$V_{CC} < 9\text{V}$, $I_{CV} < 2\text{mA}$	1.5		$V_{CC} - 3$	V
	$CMIR$	$V_{CC} \geq 9\text{V}$, $I_{CV} < 2\text{mA}$	1.5		6.0	V
Common Mode Rejection Ratio	$CMRR$		80	90		dB
Power Supply Rejection Ratio	$PSRR$		80	90		dB
Offset Voltage	V_{OS}			± 1.5	± 6	mV

UNIVERSAL AMPLIFIER IC

AM400

Parameter	Symbol	Conditions	Min.	Typ.	Max.	Unit
Instrumentation Amplifier (cont.)						
V_{OS} vs. Temperature	dV_{OS}/dT			±5		μV/°C
Input Bias Current	I_B			-100	-250	nA
I_B vs. Temperature	dI_B/dT			-0.4	-0.9	nA/°C
Output Voltage Range	V_{OUTIA}	$V_{CC} < 9V, R_{LIA} \leq 10k\Omega$	0***		$V_{CC} - 4$	V
	V_{OUTIA}	$V_{CC} \geq 9V, R_{LIA} \leq 10k\Omega$	0***		5	V
Minimum Output Voltage	$V_{OUTIAmin}$	Without external load resistance R_{LIA}		4.5	16	mV
Load Capacitance	C_L^{**}				250	pF
Zero Adjust Stage						
Internal Gain	G_{ZA}		0,94	1	1,06	
Input Voltage	V_{ZA}	$V_{ZA} \leq V_{OUTIA} - G_{IA} V_{IN}$	0		V_{OUTIA}	V
Offset Voltage	V_{OS}			±0.5	±2.0	mV
V_{OS} vs. Temperature	dV_{OS}/dT			±1.6	±5	μV/°C
Input Bias Current	I_B			47	120	nA
I_B vs. Temperature	dI_B/dT			18	30	pA/°C
Operational Amplifier Gain Stage (OP1)						
Adjustable Gain	G_{GAIN}		1			
Input Range	IR	$V_{CC} < 10V$	0		$V_{CC} - 5$	V
	IR	$V_{CC} \geq 10V$	0		5	V
Power Supply Rejection Ratio	$PSRR$		80	90		dB
Offset Voltage	V_{OS}			±0.5	±2	mV
V_{OS} vs. Temperature	dV_{OS}/dT			±3	±7	μV/°C
Input Bias Current	I_B			10	25	nA
I_B vs. Temperature	dI_B/dT			7	20	pA/°C
Output Voltage Limitation	V_{LIM}			V_{REF}		V
Output Voltage Range	V_{OUTAD}	$V_{CC} < 10V$	0		$V_{CC} - 5$	V
	V_{OUTAD}	$V_{CC} \geq 10V$	0		V_{REF}	V
Load Capacitance	C_L				250	pF
Operational Amplifier Output Stage (OP2)						
Internal Gain	G_{OP}		2.15	2.20	2.25	
Input Range	IR	$V_{CC} < 11V$	0		$V_{CC} - 5$	V
	IR	$V_{CC} \geq 11V$	0		6	V
Power Supply Rejection Ratio	$PSRR$		80	90		dB
Offset Voltage	V_{OS}			±0.5	±2	mV
V_{OS} vs. Temperature	dV_{OS}/dT			±3	±7	μV/°C
Input Bias Current	I_B			10	25	nA
I_B vs. Temperature	dI_B/dT			7	20	pA/°C
Output Voltage Range	V_{OUT}	$V_{CC} < 19V$	0		$V_{CC} - 5$	V
	V_{OUT}	$V_{CC} \geq 19V$	0		14	V
Output Current Limitation	I_{LIM}	$V_{OUT} \geq 10V$	5	7	10	mA
Output Current	I_{OUT}		0		I_{LIM}	mA
Load Resistance	R_L		2			kΩ
Load Capacitance	C_L				500	nF

UNIVERSAL AMPLIFIER IC

AM400

Parameter	Symbol	Conditions	Min.	Typ.	Max.	Unit
V/I Converter						
Internal Gain	G_{VI}		0,120	0.125	0,130	
Trim Range		Adjustable by R_0	0.75	1.00	1.25	
Voltage Range at R_0 FS	V_{R0FS}		350		750	mV
Offset Voltage	V_{OS}	$\beta_F \geq 100$		± 2	± 4	mV
V_{OS} vs. Temperature	dV_{OS}/dT	$\beta_F \geq 100$		± 7	± 14	$\mu V/^\circ C$
Input Resistance	R_{IN}		120	160		k Ω
R_{IN} vs. Temperature	dR_{IN}/dT		0.2	0.3		k $\Omega/^\circ C$
Output Offset Current	I_{OUTOS}	3-wire operation		-25	-35	μA
I_{OUTOS} vs. Temperature	dI_{OUTOS}/dT	3-wire operation		16	26	nA/ $^\circ C$
Output Offset Current	I_{OUTOS}	2-wire operation		9.5	14	μA
I_{OUTOS} vs. Temperature	dI_{OUTOS}/dT	2-wire operation		6	8	nA/ $^\circ C$
Output Control Current	I_{OUTC}	2-wire operation, $V_{R0}/100mV$		6	8	μA
I_{OUTC} vs. Temperature	dI_{OUTC}/dT	2-wire operation		-10	-15	nA/ $^\circ C$
Output Voltage Range	V_{OUT}	$V_{OUT} = R_L I_{OUT}, V_{CC} < 18V$	0		$V_{CC} - 6$	V
	V_{OUT}	$V_{OUT} = R_L I_{OUT}, V_{CC} \geq 18V$	0		12	V
Output Current Range FS	I_{OUTFS}	$I_{OUT} = V_{R0}/R_0$, 3-wire operation		20		mA
Output Resistance	R_{OUT}		0.5	1.0		M Ω
Load Capacitance	C_L		0		500	nF
SET Stage						
Internal Gain	G_{SET}			0.5		
Input Voltage	V_{SET}		0		1.15	V
Offset Voltage	V_{OS}			± 0.5	± 1.5	mV
V_{OS} vs. Temperature	dV_{OS}/dT			± 1.6	± 5	$\mu V/^\circ C$
Input Bias Current	I_B			8	20	nA
I_B vs. Temperature	dI_B/dT			7	18	pA/ $^\circ C$
Protection Functions						
Voltage Limitation at R_0	V_{LIMR0}	$V_{R0} = V_{IN} G_I, SET = GND$ Only if OP2 and V/I-Converter are connected		$V_{REF}/8$		mV
Protection against reverse polarity	V_{LIMR0}	$V_{IN} = 0, V_{R0} = V_{SET}/2$ Ground vs. V_S vs. V_{OUT} Ground vs. V_S vs. I_{OUT}	580	635	690	mV
Current in case of reverse polarity		Ground = 35V, $V_S = I_{OUT} = 0$		4.5		mA
System Parameters						
Nonlinearity		Ideal input		0.05	0.15	%FS

* In 2-wire operation a maximum current of $I_{OUTmin} - I_{CC}$ is valid

** Only available in die form or in an SSOP 20 version

*** Depending on external load resistance at output IA ($R_{LIA} \leq 10k\Omega \Rightarrow V_{OUTIA} < 3mV$); internal load resistance is $\approx 100k\Omega$

UNIVERSAL AMPLIFIER IC

AM400

BOUNDARY CONDITIONS

Parameter	Symbol	Conditions	Min.	Typ.	Max.	Unit
Sense Resistor	R_0	$I_{OUTFS} = 20\text{mA}$	17	27	38	Ω
	R_0	$c = 20\text{mA}/I_{OUTFS}$	$c \cdot 17$	$c \cdot 27$	$c \cdot 38$	Ω
Stabilization Resistor	R_5	$I_{OUTFS} = 20\text{mA}$	35	40	45	Ω
	R_5	$c = 20\text{mA}/I_{OUTFS}$	$c \cdot 35$	$c \cdot 40$	$c \cdot 45$	Ω
Load Resistance	R_L	Limitation only for 3-wire operation	0		600	Ω
Sum Gain Resistors	$R_1 + R_2$		20		200	k Ω
Sum Offset Resistors	$R_3 + R_4$		20		200	k Ω
V_{REF} Capacitance	C_1	Min. value for $T_{amb} 85^\circ\text{C}$	1.9	2.2	5.0	μF
Output Capacitance	C_2	Only for 2-wire operation	90	100	250	nF
D_1 Breakdown Voltage	V_{BR}		35	50		V
T_1 Forward Current Gain	β_F	BCX54/55/56, for example	50	150		

DETAILED DESCRIPTION OF FUNCTIONS

AM462 is a modular, monolithically integrated universal amplifier which has been specifically developed for the conditioning of differential voltage signals and those referenced to ground. It is designed for both 2- and 3-wire operation¹ in industrial applications (cf. applications on pages 14 until 19). AM462's various functions are depicted in the block diagram (Figure 1) which also illustrates how few external components are required for the operation of this particular device.

AM400 consists of a number of modular functional blocks which through external gating can either operate together or separately (see Figure 2).

1. The *instrumentation amplifier* (IA) with an internal gain of $G_{IA} = 5$ acts as an input stage for differential voltage signals. Its special construction permits a high common mode rejection ratio (CMRR). The amplifier reference potential is set externally using the AM400 pin ZA . Output voltage V_{OUTIA} at pin $OUTIA$ is calculated for $V_{ZA} > 0$ as:

$$V_{OUTIA} = G_{IA} V_{IN} + V_{ZA} \quad \text{with } V_{OUTIA} > 0 \quad (1)$$

where V_{IN} is the differential voltage between inputs pin $IN+$ and pin $IN-$ of the IA and V_{ZA} is the voltage at pin ZA .

2. The ensuing *operational amplifier stage* (OP1) permits the IA output signal to be amplified further. OP1's gain of G_{GAIN} can be set using external resistors R_1 and R_2 . Protection against overvoltage has been integrated into the device; this protective circuitry limits the voltage to the set reference voltage value (cf. paragraph 5 in this section).

¹ The principle of design is such that only the current output can be used in 2-wire operation.

UNIVERSAL AMPLIFIER IC

AM400

Output voltage V_{OUTAD} at pin $OUTAD$ is calculated as:

$$V_{OUTAD} = V_{INOP} \cdot G_{GAIN} \text{ with } G_{GAIN} = \left(\frac{R_1}{R_2} + 1 \right) \quad (2)$$

where V_{INOP} is the voltage at the OP1 input pin $INOP$. Alternatively, the OP1 input pin $INOP$ can also be used as an input for signals referenced to ground (see Application 2, Figure 6).

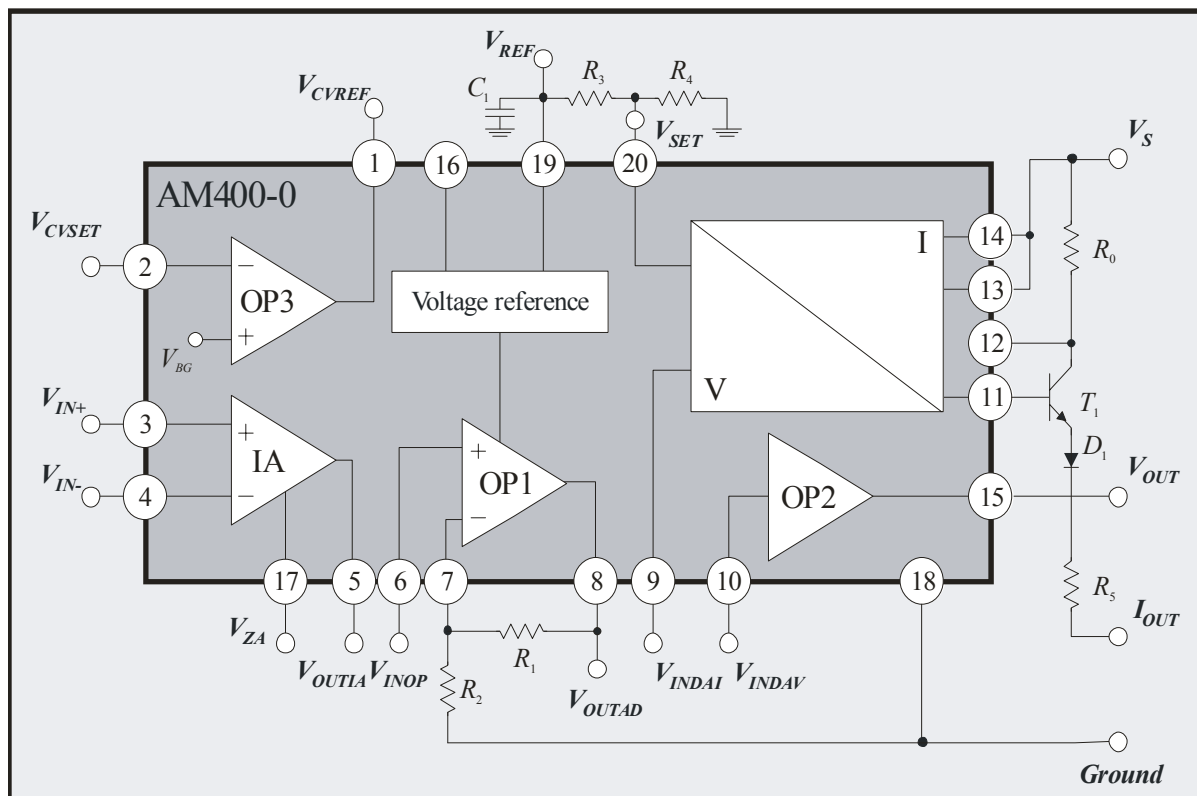

Figure 2: Block diagram of AM400 showing external components (3-wire circuit with a current output)

- The IC's voltage output V_{OUT} is realized via the current-limited *operational amplifier stage* (OP2) which has integrated protection against reverse polarity. The internal gain of OP2 is set to a fixed value of $G_{OP} = 2.2$. The output is engineered as a driver stage. The following applies to OP2's output voltage V_{OUT} at the IC pin V_{OUT} :

$$V_{OUT} = G_{OP} \cdot V_{INDAV} \quad (3)$$

where V_{INDAV} is the voltage at pin $INDAV$ (OP2 input).

UNIVERSAL AMPLIFIER IC

AM400

4. The voltage-to-current converter (V/I converter) provides a voltage-controlled current signal at IC output I_{OUT} which activates an external transistor T_1 ; this reduces the power dissipation of the IC and supplies the output current I_{OUT} . The external transistor is protected against reverse polarity by an additional diode D_1 . Via pin SET an offset current I_{SET} can be set at output I_{OUT} (with the help of the internal voltage reference and an external voltage divider as shown in Figure 5, for example). External resistor R_0 permits the output current to be finely adjusted with parallel operation of current and the voltage output. For the output current I_{OUT} boosted by T_1 the following ratio applies:

$$I_{OUT} = \frac{V_{INDAI}}{8R_0} + I_{SET} \quad \text{with} \quad I_{SET} = \frac{V_{SET}}{2R_0} \quad (4)$$

with V_{INDAI} the voltage at pin $INDAI$ and V_{SET} the voltage at pin SET (V/I converter inputs, see Figure1)².

5. The AM400 *reference voltage source* enables voltage to be supplied to external components (such as sensors, microprocessors, etc.). The reference voltage value V_{REF} can be set via pin $VSET$. If pin $VSET$ is not connected, $V_{REF} = 5V$; if $VSET$ is switched to ground, $V_{REF} = 10V$. Values between the above can be set if two external resistors are used (inserted between pin $VREF$ and pin $VSET$ and between pin $VSET$ and GND).

External capacitor C_1 stabilizes the reference voltage. It **must** be connected even if the voltage reference is not in use. It also must not exceed the minimum value.

6. The additional *operational amplifier* (OP3) can be used as a current or voltage source for the supply of external components. OP3's positive input is connected internally to voltage V_{BG} so that the output current or voltage can be set across a wide range using one or two external resistors.

² The construction of the V/I converter is such that output current I_{OUT} is largely independent of the current amplification β_F of external transistor T_1 . Production-specific variations in the current amplification of the transistors used are compensated for internally by the V/I converter.

UNIVERSAL AMPLIFIER IC

AM400

OPERATING AM400

General information on 2- and 3-wire applications

In 3-wire operation (cf. Figure 5, for example) the ground of the IC (pin *GND*) is connected up to the external mass of the system *Ground*. The system's supply voltage V_S is connected to pin *VCC* and pin *VCC* to pin *RS+*.

In 2-wire operation (cf. Figure 7) system supply voltage V_S is connected to pin *RS+* and pin *VCC* to *RS-*. The ground of the IC (pin *GND*) is connected to the node between resistor R_S and load resistor R_L (current output I_{OUT}). IC ground (*GND*) is **not** the same as system ground (*Ground*)!! The output signal is picked up via load resistor R_L which connects current output I_{OUT} to the system ground.

In 2-wire operation the IC ground is "virtual" (floating), as with a constant load resistance the supply voltage of the device V_{CC} changes according to the current. As a rule, the following equation applies to 2-wire operation:

$$V_{CC} = V_S - I_{OUT}(V_{IN}) R_L \quad (5)$$

The reason for this is that in 2-wire operation the IC is connected in series to the actual load resistor R_L . This is illustrated in Figure 3.

In 3-wire operation Equation 5 no longer applies as the IC ground is connected to the ground of the system. For 3-wire operation the supply voltage can be expressed thus:

$$V_{CC} = V_S \quad (6)$$

In a 2-wire setup the power consumption of the overall system (AM400 and all external components including the adjusting resistors) may not exceed I_{OUTmin} (usually 4mA).

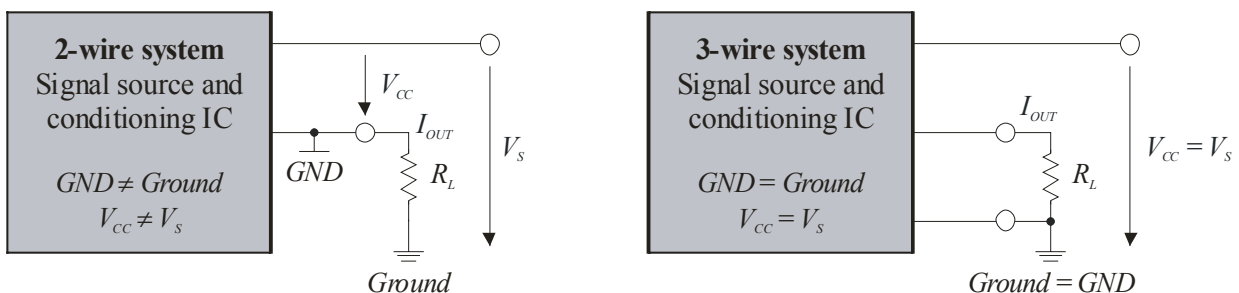

Figure 3: The difference between 2- and 3-wire operation

UNIVERSAL AMPLIFIER IC

AM400

Setting the voltage gain using the voltage output

When using the IA and amplifier stages OP1 and OP2 for further signal conditioning the overall gain can be set using the suitably selected external resistors R_1 and R_2 . The transfer function for the output voltage is calculated by multiplying Equations 1, 2 and 3 to:

$$V_{OUT} = (G_{IA}V_{IN} + V_{ZA}) \cdot G_{GAIN} \cdot G_{OP} \quad (7)$$

with $G_{IA} = 5$, $G_{GAIN} = (R_1/R_2) + 1$ and $G_{OP} = 2.2$ and the externally set voltage V_{ZA} at pin ZA.

Setting the output current range and compensating for the offset using the current output

When using the IA together with amplifier stage OP1 and the V/I converter for further signal conditioning the offset of the output current should first be compensated for. To this end the two IA inputs must be short-circuited ($V_{IN} = 0$) and connected up to a permitted potential (cf. CMIR in the electrical specifications on page 5). With the short circuit at the input the values of the output current according to Equation 4 and an external voltage divider (e.g. Figure 5) are as follows:

$$I_{OUT}(V_{IN} = 0) = I_{SET} \quad \text{with} \quad I_{SET} = \frac{V_{REF}}{2R_0} \cdot \frac{R_4}{R_3 + R_4} \quad (8)$$

The output current range is set in conjunction with the selected external resistors R_1 and R_2 (or fine adjustment with R_0). Using Equations 2, 4 and 8 the following is calculated for output current I_{OUT} :

$$I_{OUT} = V_{IN} \frac{G_I}{8R_0} + I_{SET} \quad \text{with} \quad G_I = G_{IA} \cdot G_{GAIN} \quad \text{and} \quad V_{ZA} = 0 \quad (9)$$

Selecting the supply voltage

System supply voltage V_S needed to operate AM400 is dependent on the selected mode of operation.

- When using voltage output pin V_{OUT} the minimum supply voltage V_S necessary for the operation of the device depends on the maximum output voltage V_{OUTmax} required by the application. The following applies:

$$V_S \geq V_{OUTmax} + 5V \quad (10)$$

- When using current output pin I_{OUT} (in conjunction with the external transistor) the value of V_S is dependent on that of the relevant load resistor R_L (max. 600 Ω) used by the application. The minimum system supply voltage V_S is then:

$$V_S \geq I_{OUTmax} R_L + V_{CCmin} \quad (11)$$

UNIVERSAL AMPLIFIER IC

AM400

Here, I_{OUTmax} stands for the maximum output current and V_{CCmin} for the minimum IC supply voltage which is dependent on the selected reference voltage:

$$V_{CCmin} \geq V_{REF} + 1V \quad (12)$$

The working range resulting from Equation 11 is described in Figure 4. Example calculations and typical values for the external components can be found in the example applications.

POINTS TO NOTE: INITIAL OPERATION OF AM400

1. When operating AM400 it is imperative that external capacitance C_1 (a high-grade ceramic capacitor) is **always** connected (cf. Figure 2). Care must be taken that the value of the capacitance does not lie beyond its given range, even across the range of temperature (see Boundary Conditions on page 7). In 2-wire operation ceramic capacitor C_2 must also be used.

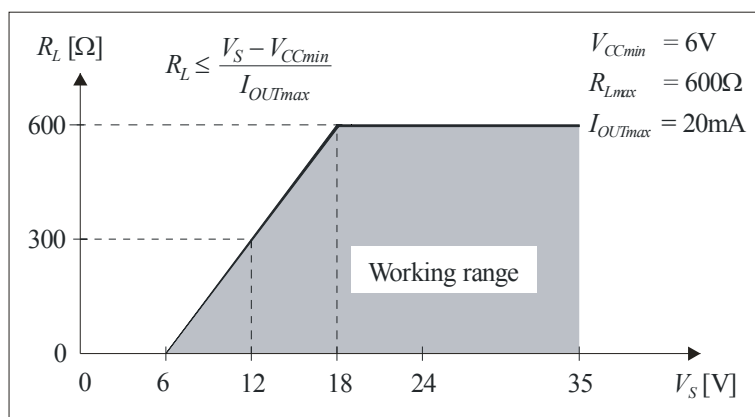

Figure 4: Working range in conjunction with the load resistor

2. All of the AM400 function blocks not used by the application (e.g. OP3) must be connected up to a defined (and permitted) potential.
3. The voltages at the IA inputs (pins $IN+$ and $IN-$) must **always** lie within input voltage range $CMIR$, even if the IA is not used.
4. When the voltage output is in operation the load resistance at pin $VOUT$ must be **at least** $2k\Omega$.
5. A load resistance of 600Ω **maximum** is permitted with operation of the current output.
6. The values of external resistors R_0 , R_1 , R_2 , R_3 , R_4 and R_5 must be selected within the permissible range given in the boundary conditions on page 7.

UNIVERSAL AMPLIFIER IC AM400

APPLICATIONS

1) Typical 3-wire application with a differential input signal

In 3-wire operation (cf. Figure 5, for example) the IC ground (pin *GND*) is connected up to the external ground of the system (*Ground*). The system's supply voltage V_S is connected to pin *VCC* and pin *VCC* to pin *RS+*.

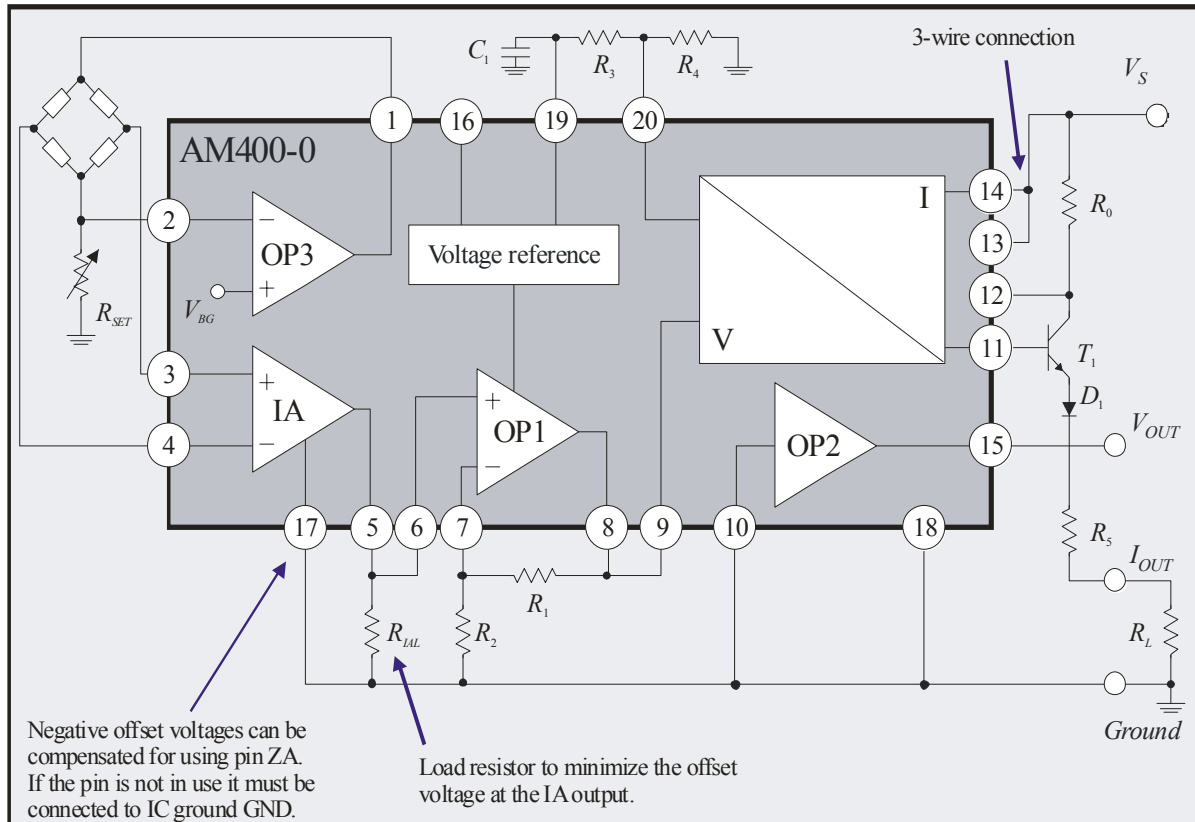

Figure 5: Typical 3-wire application for differential input

Figure 5 shows a 3-wire application in which the differential output signal of a current-powered measuring bridge is amplified and converted. Operational amplifier OP3 supplies the measuring bridge with current. Bridge supply current I_S can be set using resistor R_{SET} :

$$I_S = \frac{V_{BG}}{R_{SET}} = \frac{1.27 \text{ V}}{R_{SET}} \quad (13)$$

For the above application it is assumed that no negative input voltages are present. Pin *ZA* is first connected to the IC's ground *GND*. According to Equation 3 the following then applies to output voltage V_{OUT} :

$$V_{OUT} = G_V V_{IN} \text{ with } G_V = G_{IA} G_{GAIN} G_{OP} = 5 \left(1 + \frac{R_1}{R_2} \right) 2.2 \quad (14)$$

UNIVERSAL AMPLIFIER IC AM400

According to Equation 4 the following is then relevant to output current I_{OUT} :

$$I_{OUT} = V_{IN} \frac{G_I}{8R_0} + I_{SET} \quad \text{with } V_{ZA} = 0 \quad (15)$$

with $G_I = G_{IA} \cdot G_{GAIN} = 5 \left(1 + \frac{R_1}{R_2} \right)$ and $I_{SET} = \frac{V_{REF}}{2R_0} \cdot \frac{R_4}{R_3 + R_4}$.

Example 1: $V_{IN} = 0...100\text{mV}$ (differential), $I_{OUT} = 4...20\text{mA}$ and $V_{OUT} = 0...10\text{V}$

For a measuring bridge with a signal of $V_{IN} = 0...100\text{mV}$ at the IA input the external components are to be dimensioned in such a way that the output current has a range of 4...20mA and the output voltage one of 0...10V.

R_1 and R_2 are dimensioned in accordance with Equation 14, R_0 according to Equation 4 and R_3 and R_4 according to Equation 8. Observing the boundary conditions for the external components the following values are then obtained:

$R_0 \approx 35.5\Omega$	$R_1 \approx 80.9\text{k}\Omega$	$R_2 = 10\text{k}\Omega$	$R_3 = 83\text{k}\Omega$	$R_4 = 5\text{k}\Omega$
$R_5 = 39\Omega$	$R_L = 0...600\Omega$	$R_{IAL} \leq 10\text{k}\Omega$	$C_1 = 2.2\mu\text{F}$	

2) Typical 3-wire application with an input signal referenced to ground

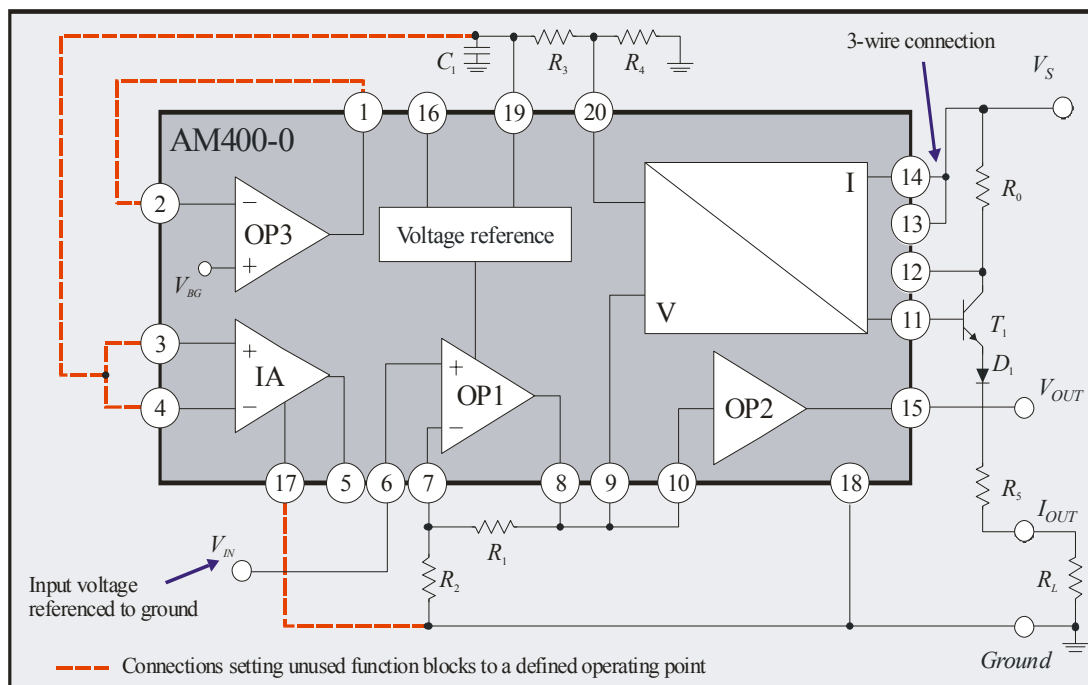

Figure 6: Typical application for input signals referenced to ground

UNIVERSAL AMPLIFIER IC

AM400

Figure 6 shows a 3-wire application in which AM400 amplifies and converts a voltage signal referenced to ground. The blocks unused by the application (IA and OP3) are set to a defined operating point. Alternatively, these function blocks can also be used for the supply of external components, for example.

In the above application output voltage V_{OUT} is calculated using Equations 2 and 3 as:

$$V_{OUT} = G_V V_{IN} \quad \text{with} \quad G_V = G_{GAIN} \quad G_{OP} = \left(1 + \frac{R_1}{R_2}\right) 2.2$$

According to Equation 4 the following applies to output current I_{OUT} :

$$I_{OUT} = V_{IN} \frac{G_I}{8R_0} + I_{SET}$$

$$\text{with } G_I = G_{GAIN} = \left(1 + \frac{R_1}{R_2}\right) \quad \text{and} \quad I_{SET} = \frac{V_{REF}}{2R_0} \cdot \frac{R_4}{R_3 + R_4}$$

Example 2: $V_{IN} = 0 \dots 1\text{V}$ (referenced to ground), $I_{OUT} = 4 \dots 20\text{mA}$ and $V_{OUT} = 0 \dots 10\text{V}$

For a signal of $V_{IN} = 0 \dots 1\text{V}$ at the OP1 input the external components are to be dimensioned in such a way that the output current has a range of $4 \dots 20\text{mA}$ and the output voltage one of $0 \dots 10\text{V}$.

Observing the boundary conditions the following values are obtained for the external components:

$$\begin{array}{lllll} R_0 \approx 35.5\Omega & R_1 \approx 35.5\text{k}\Omega & R_2 = 10\text{k}\Omega & R_3 = 83\text{k}\Omega & R_4 = 5\text{k}\Omega \\ R_5 = 39\Omega & R_L = 0 \dots 600\Omega & C_1 = 2.2\mu\text{F} & & \end{array}$$

3) Typical 2-wire application with a differential input signal

In 2-wire operation (cf. Figure 7) system supply voltage V_S is connected up to pin $RS+$ and pin VCC to pin $RS-$. The ground of the IC (pin GND) is connected to the node between resistor R_5 and load resistor R_L (current output I_{OUT}). IC ground (GND) is **not** the same as system ground ($Ground$)!! The output signal is picked up via load resistor R_L which connects current output I_{OUT} to the system ground.

Figure 7 shows a typical 2-wire application in which the differential output signal of a current-powered measuring bridge is amplified by the IA and OP1 and converted by the V/I converter. Operational amplifier OP3 supplies the measuring bridge with current. Bridge supply current I_S can be set using resistor R_{SET} according to Equation 13.

According to Equation 4 the following applies to the output current of the 2-wire application:

$$I_{OUT} = V_{IN} \frac{G_I}{8R_0} + I_{SET} \quad \text{with} \quad V_{ZA} = 0 \quad (ZA \text{ connected to } GND)$$

UNIVERSAL AMPLIFIER IC AM400

where $G_I = G_{IA}$ $G_{GAIN} = 5 \left(1 + \frac{R_1}{R_2} \right)$ and $I_{SET} = \frac{V_{REF}}{2R_0} \cdot \frac{R_4}{R_3 + R_4}$

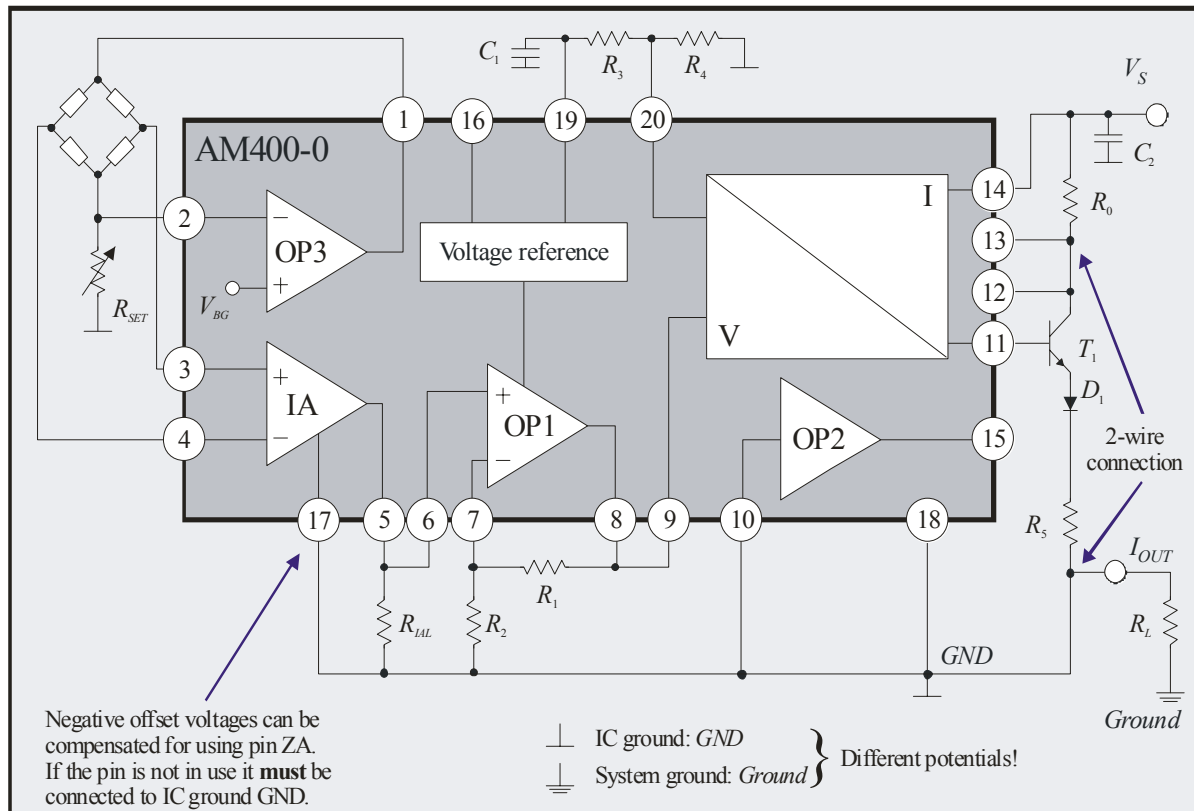

Figure 7: Typical 2-wire application for differential input signals

Example 3: $V_{IN} = 0..100\text{mV}$ (differential) and $I_{OUT} = 4..20\text{mA}$

For a measuring bridge with a signal of $V_{IN} = 0..100\text{mV}$ at the IA input the external components of the AM400 circuitry are to be dimensioned in such a way that the output current has a range of 4...20mA.

As only the current output is to be used, the gain and output current range can be dimensioned using resistors R_1 to R_4 . Up to a certain point the value of resistor R_0 is freely selectable and can be set to 27Ω . Observing the boundary conditions for the external components the following values are then obtained:

$R_0 = 27\Omega$	$R_1 \approx 59.12\text{k}\Omega$	$R_2 = 10\text{k}\Omega$	$R_3 = 82\text{k}\Omega$	$R_4 = 5\text{k}\Omega$
$R_5 = 39\Omega$	$R_L = 0..600\Omega$	$R_{IAL} \leq 10\text{k}\Omega$	$C_1 = 2.2\mu\text{F}$	$C_2 = 100\text{nF}$

In this specific application particular attention must be paid to the current consumption which at a temperature of 85°C may not exceed 4mA.

UNIVERSAL AMPLIFIER IC

AM400

4) Application for the 16-pole version of AM400 (3-wire application)

Figure 8 gives a 3-wire application which uses the 16-pole version of AM400 (Figure 11). The dimensions of this specific application are no different from those of the 3-wire setup illustrated in Figure 5; no detailed description shall thus be given here. One difference, however, lies in the fact that the minimum voltage at the IA output cannot be reduced by connecting up external load resistor R_{LIA} . Particularly with small differential input signs and the large G_{OP} gain these entail a “correct” value of 0V cannot be obtained at IC output V_{OUT} (cf. the comments on V_{OUTIA} in the electrical specifications). For this reason the 20-pole version of AM400 is preferable for small signals.

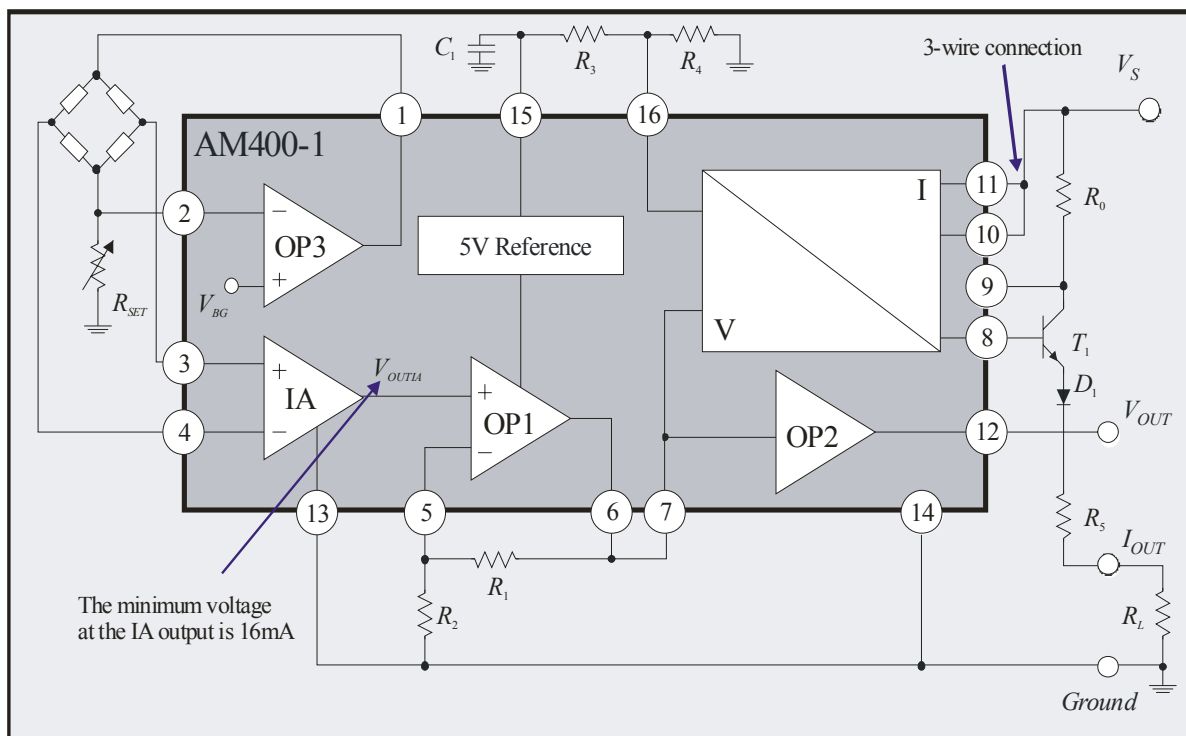

Figure 8: Typical application for the 16-pole version of AM400 (3-wire)

UNIVERSAL AMPLIFIER IC AM400

BLOCK DIAGRAM, 20-POLE PINOUT AND DICE

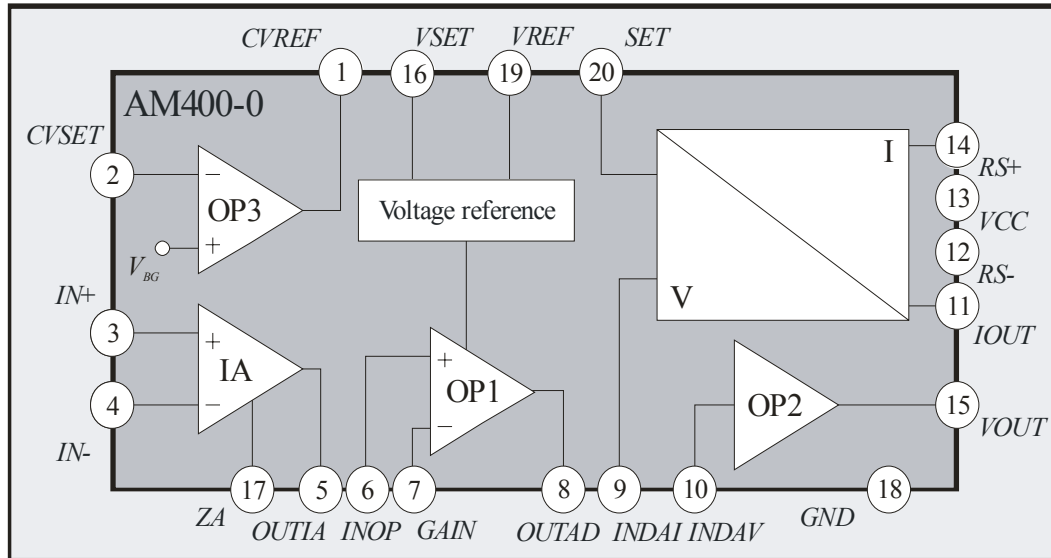

Figure 9: Block diagram of AM400 in the 20-pole version

PIN	NAME	EXPLANATION
1	CVREF	Current/Voltage reference
2	CVSET	Current/Voltage reference set
3	IN+	Positive input IA
4	IN-	Negative input IA
5	OUTIA	Output IA
6	INOP	Positive amplification OP input
7	GAIN	Gain set
8	OUTAD	System gain output
9	INDAI	Current output stage input
10	INDAV	Voltage output stage input
11	IOUT	Current output
12	RS-	Sensor resistor -
13	VCC	Supply voltage
14	RS+	Sensor resistor +
15	VOUT	Voltage output
16	VSET	Set reference voltage source
17	ZA	Zero adjustment (offset)
18	GND	IC ground
19	VREF	Reference voltage source output
20	SET	Output offset current set

Table 1: Pinout of the 20-pole version of AM400

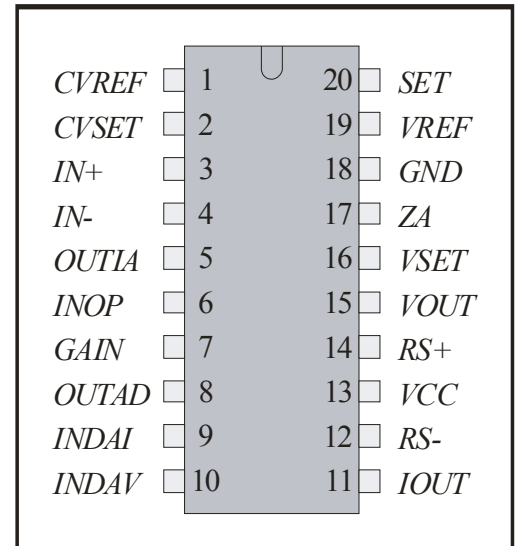

Figure 10: Pinout of the 20-pole version of AM400

UNIVERSAL AMPLIFIER IC AM400

BLOCK DIAGRAM AND 16-POLE PINOUT

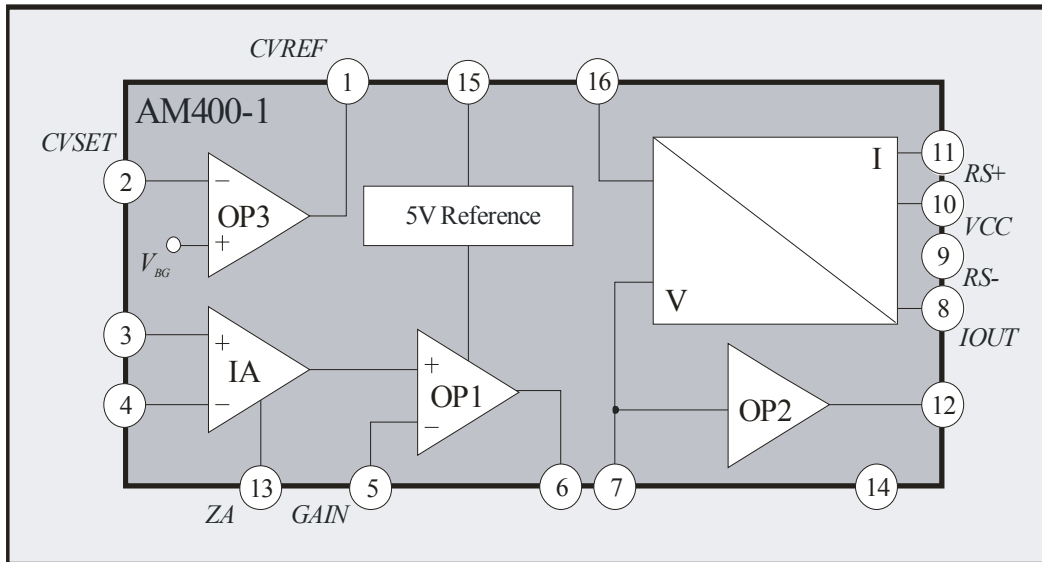

Figure 11: Block diagram of AM400 in the 16-pole version

PIN	NAME	EXPLANATION
1	<i>CVREF</i>	Current/Voltage reference
2	<i>CVSET</i>	Current/Voltage reference set
3	<i>IN+</i>	Positive input IA
4	<i>IN-</i>	Negative input IA
5	<i>GAIN</i>	Gain set
6	<i>OUTAD</i>	System gain output
7	<i>INDA</i>	Output stage input
8	<i>IOUT</i>	Current output
9	<i>RS-</i>	Sensor resistor -
10	<i>VCC</i>	Supply voltage
11	<i>RS+</i>	Sensor resistor +
12	<i>VOUT</i>	Voltage output
13	<i>ZA</i>	Zero adjustment (offset)
14	<i>GND</i>	IC ground
15	<i>VREF</i>	Reference voltage source output
16	<i>SET</i>	Output offset current set

Table 2: Pinout of the 16-pole version of AM400

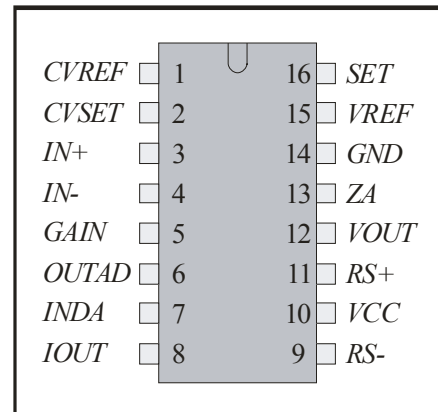

Figure 12: Pinout of the 16-pole version of AM400

UNIVERSAL AMPLIFIER IC AM400

EXAMPLE APPLICATIONS

- Signal conditioning for ceramic and piezoresistive pressure sensing elements with an optional external processor for error compensation

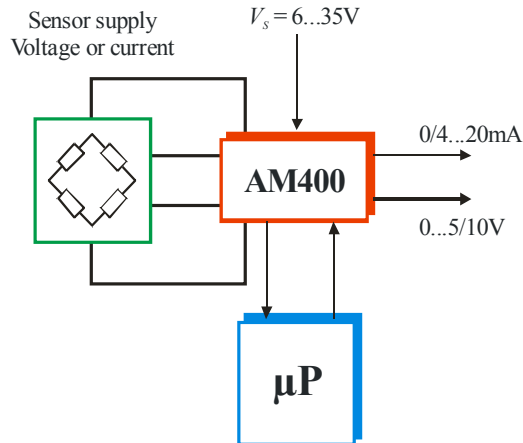

Figure 13: Application for ceramic and piezoresistive pressure sensors and an external microcontroller

- Application as a converter IC

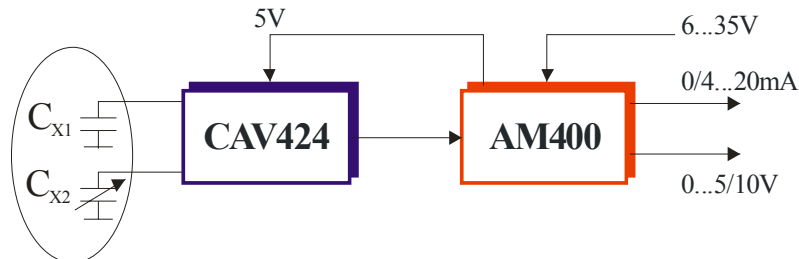

Figure 14: Application as a converter IC together with CAV424 for the measurement of capacitive V424 signals

- Conditioning of signals referenced to ground (protected output stage, impedance converter, etc.)

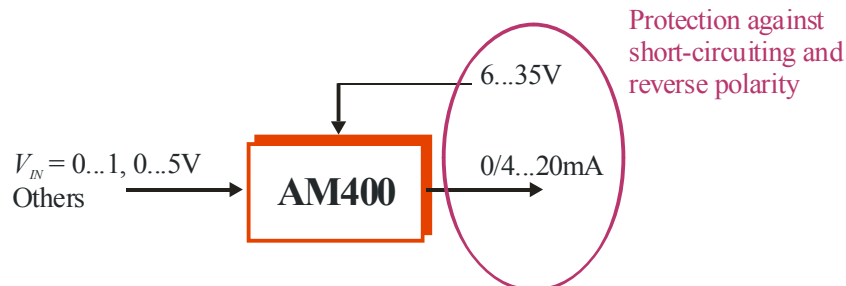

Figure 15: Application for input signals referenced to ground (protected output stage, impedance converter, etc.)

UNIVERSAL AMPLIFIER IC

AM400

DELIVERY

The AM400 sensor transmitter is available as the following packages:

- SSOP20
- SO16(n)
- Dice on 5" blue foil (on request)

PACKAGE DIMENSIONS

Please see our website (data sheets: package.pdf).

FURTHER READING

- [1] The Frame ASIC concept: <http://www.Frame-ASIC.de/>
- [2] The Analog Microelectronics GmbH website: <http://www.analogmicro.de/>

Analog Microelectronics reserves the right to make amendments to any dimensions, technical data or other information contained herein without further notice.

analog microelectronics

Analog Microelectronics GmbH
An der Fahrt 13, D – 55124 Mainz
Internet: <http://www.analogmicro.de>

Phone: +49 (0)6131/91 073 – 0
Fax: +49 (0)6131/91 073 – 30
Email: info@analogmicro.de

October 2005
21/21
Rev.: 4.2