

GOIT1050

10" color TFT, 1024 x 768, Compact Operator Interface Terminal with Drop in Replacement for Siemens SIMATIC Line



Introduction

The AIS 10" compact web-based and ARM-based HMI solutions are one of the most versatile operator interface choices for visualization applications. The AIS operator terminals are ideal for applications that require monitoring, controlling and displaying information in dynamic ways, where operators must quickly understand machine status and make better decisions. These graphic operator interface terminals are ideally designed for use in process and discrete manufacturing, industrial automation and process control applications.

Specifications

Display	
Display	10"
Active/Area	203 x 152
Native (Optimal) Resolution	1024 x 768
Colors	65,536
Brightness (Typical)	Yes
Touch screen Type	Resistive analog
Display position	Both horizontal & vertical
Language Fonts	Unicode including Simplified and Traditional Chinese, Japanese & Korean
System Hardware	
Processor, CPU speed	ARM Cortex-A8, 667Mhz
Flash Memory (ROM)	128 MB
SDRAM (RAM)	256 MB
Operation System	WinCE 6.0
SD card slot	Yes

Features and Benefits

- Flexible, reliable, and ruggedized for open platform HMI
- Web and Windows CE-based with integrated CPU, RAM, storage, USB, RS232, RS422/485 and Ethernet ports
- Compact web-based thin clients for faster, better and lower-cost HMI applications
- Ruggedized levels of NEMA 12, 4X, 4, IP52, IP54, IP66 ratings
- Technical support for drivers, hardware, troubleshooting procedures and general system issues
- Customer service and sales support for product selection, order management, and warranty status







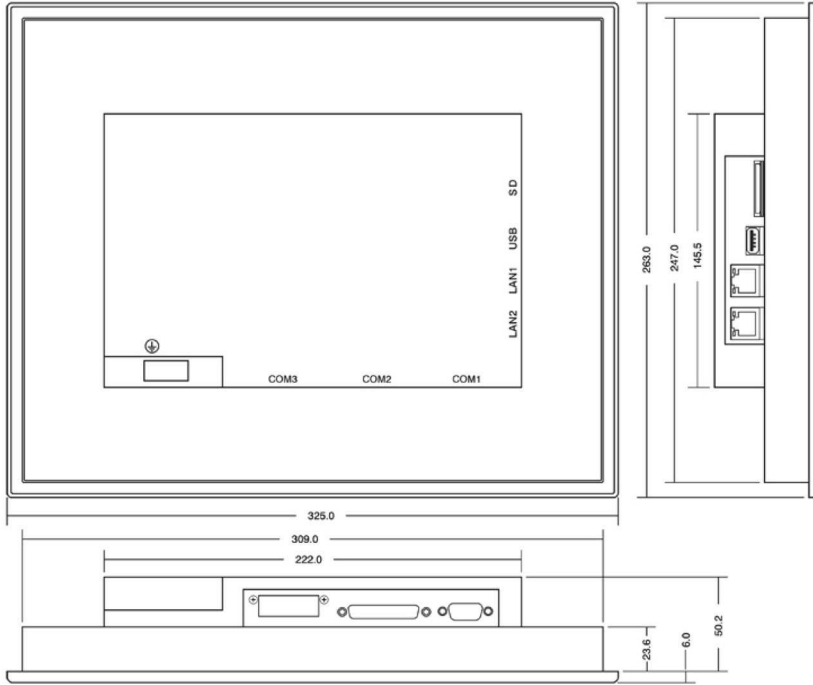

Interfaces	
RS232C, DB9 Male	1
RS232C/ RS422/ RS485, DB25 Female	1
Ethernet 10/100 Mbps, RJ45	2
USB Host	1
General	
Power Supply	11-36VDC,90-250VAC
Consumption (w/o sound output)	15 W
Power on LED indicator	Yes
Outer dimensions (W x H x D mm)	325 x 263 x 56
Communication Interface	
MPI/PROFIBUS DP, PROFINET	Option
DeviceNet, EtherNet/IP	Option
CANopen, EtherCAT	Option
BACnet/IP	Option
Approvals	
Approvals	UL 508 and CSA C22.2 No.142, FCC Part 15, Subpart B, Class A

Order Information

GOIT1050: 10" Compact Operator Interface Terminal with Drop in Replacement for Siemens SIMATIC Line, 1024 x 768

Unit: mm



-  — DB9 Male
-  — DB25 Female
-  — Network Option
-  — LAN1 Ethernet
-  — LAN2 Ethernet
-  — SD Slot
-  — USB
-  — Power Supply