

THE INFORMATION CONTAINED HEREIN IS CONSIDERED "PROPRIETARY" TO BEL FUSE INC. AND SHALL NOT BE COPIED, REPRODUCED OR DISCLOSED WITHOUT THE WRITTEN APPROVAL OF BEL FUSE INC.

PRELIMINARY



ELECTRICAL CHARACTERISTICS @ 25°C

URNS RATIO

TX 1CT : 1
 RX 1CT : 1

□CL @ 100kHz/100mVRMS

8mA DC BIAS (0°C - 70°C) 350μH MIN.

INS. LOSS

1MHz TO 100MHz -1.0 dB MAX

RET. LOSS (MIN)

1MHz-30MHz -18 dB
 30MHz-60MHz $-18+20\text{LOG}(F/30\text{MHz})$ dB
 60MHz-80MHz -12 dB

CROSS TALK (TX - RX)

100KHZ-100 MHz -35 dB MIN

CM TO CM REJ

100KHZ-100 MHz -30 dB MIN

CM TO DM REJ

100KHZ-100 MHz -35 dB MIN

HIPOT (Isolation Voltage):

1500 Vrms

100% OF PRODUCTION TESTED

TO COMPLY WITH IEEE 802.3 ISOLATION REQUIREMENTS.

SCHEMATIC

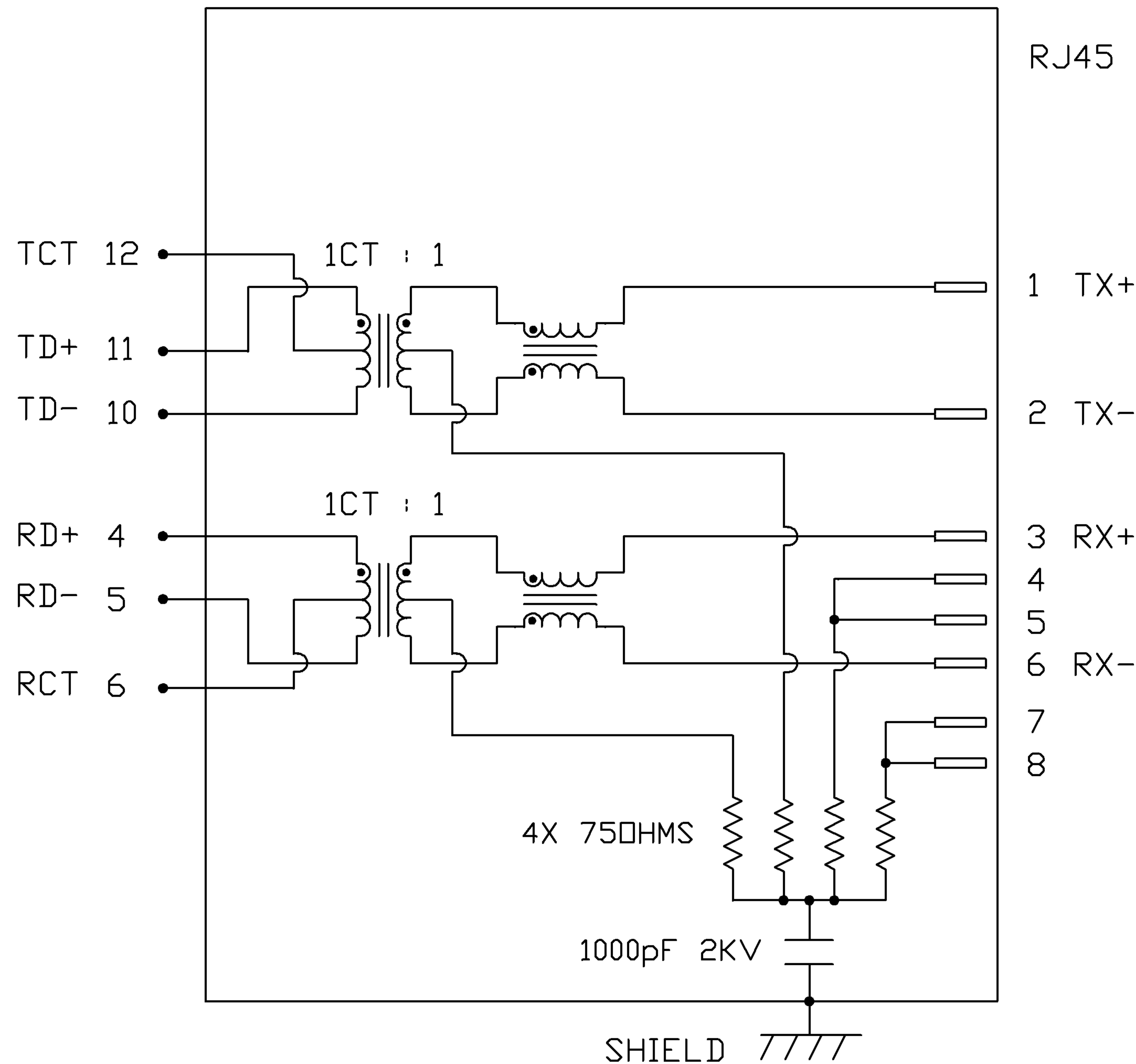

| | | | | | | | | |
|---------------|----------|---------------------|------------------------|--|--------------|------------------------------|-------------|---------------------------------------|
| ORIGINATED BY | DATE | TITLE | PART NO. / DRAWING NO. | STANDARD DIM. | | [] METRIC DIM. AS REFERENCE | | COMPONENTS FOR A CONNECTED PLANET |
| CHOW WANCHUNG | 04-23-08 | | | 10/100 MagJack® (Ultra Low Profile) | L837-1X1C-06 | TOL. IN INCH | | |
| DRAWN BY | DATE | FILE NAME | .X | | | / | SCALE : N/A | |
| WEIDE LEE | 04-23-08 | L837-1X1C-06_PA.DWG | .XX | .XXX | | | PAGE : 2 | |

THE INFORMATION CONTAINED HEREIN IS CONSIDERED "PROPRIETARY" TO BEL FUSE INC. AND SHALL NOT BE COPIED, REPRODUCED OR DISCLOSED WITHOUT THE WRITTEN APPROVAL OF BEL FUSE INC.

MECHANICAL SPECIFICATION

RoHS
2002/95/EC

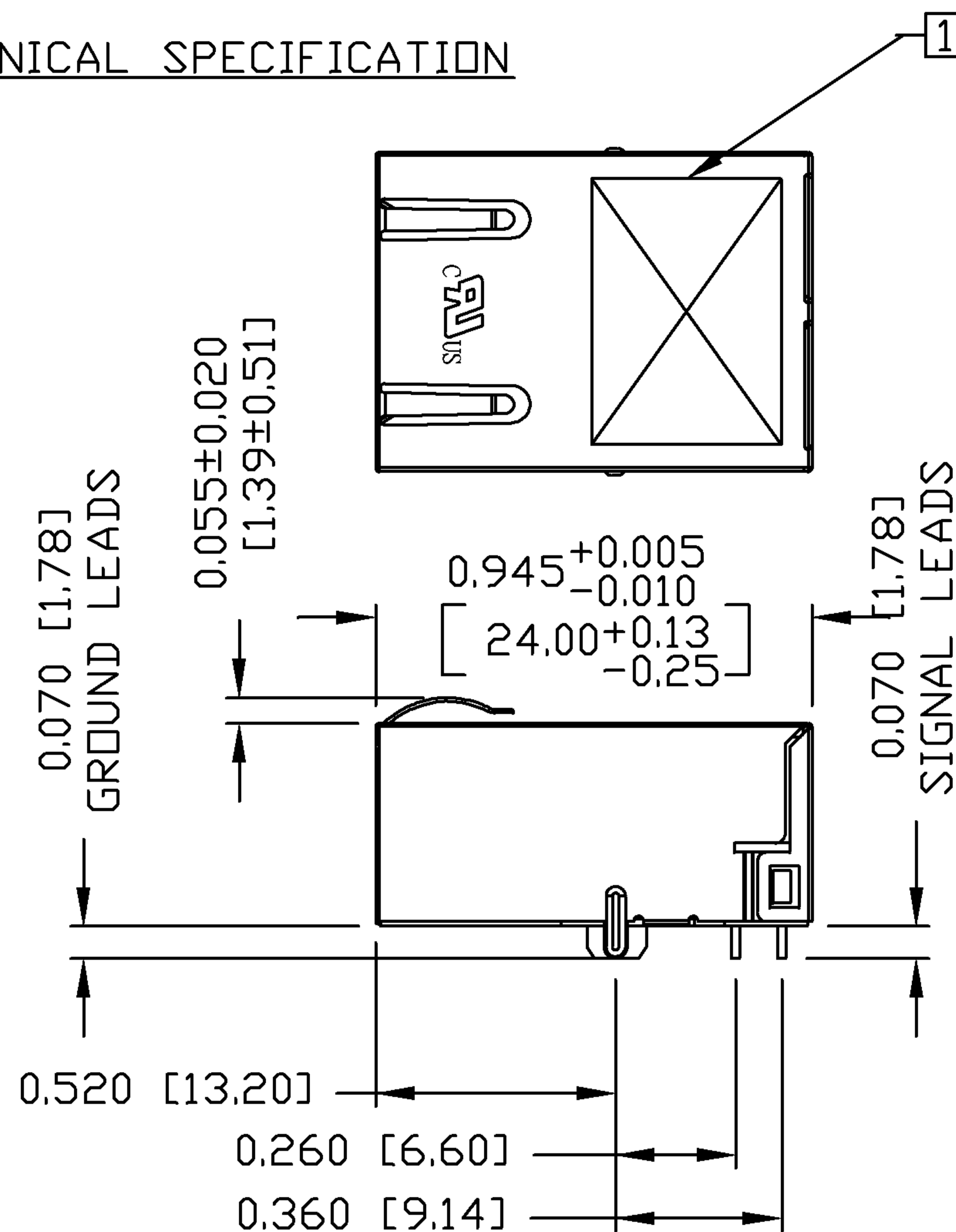
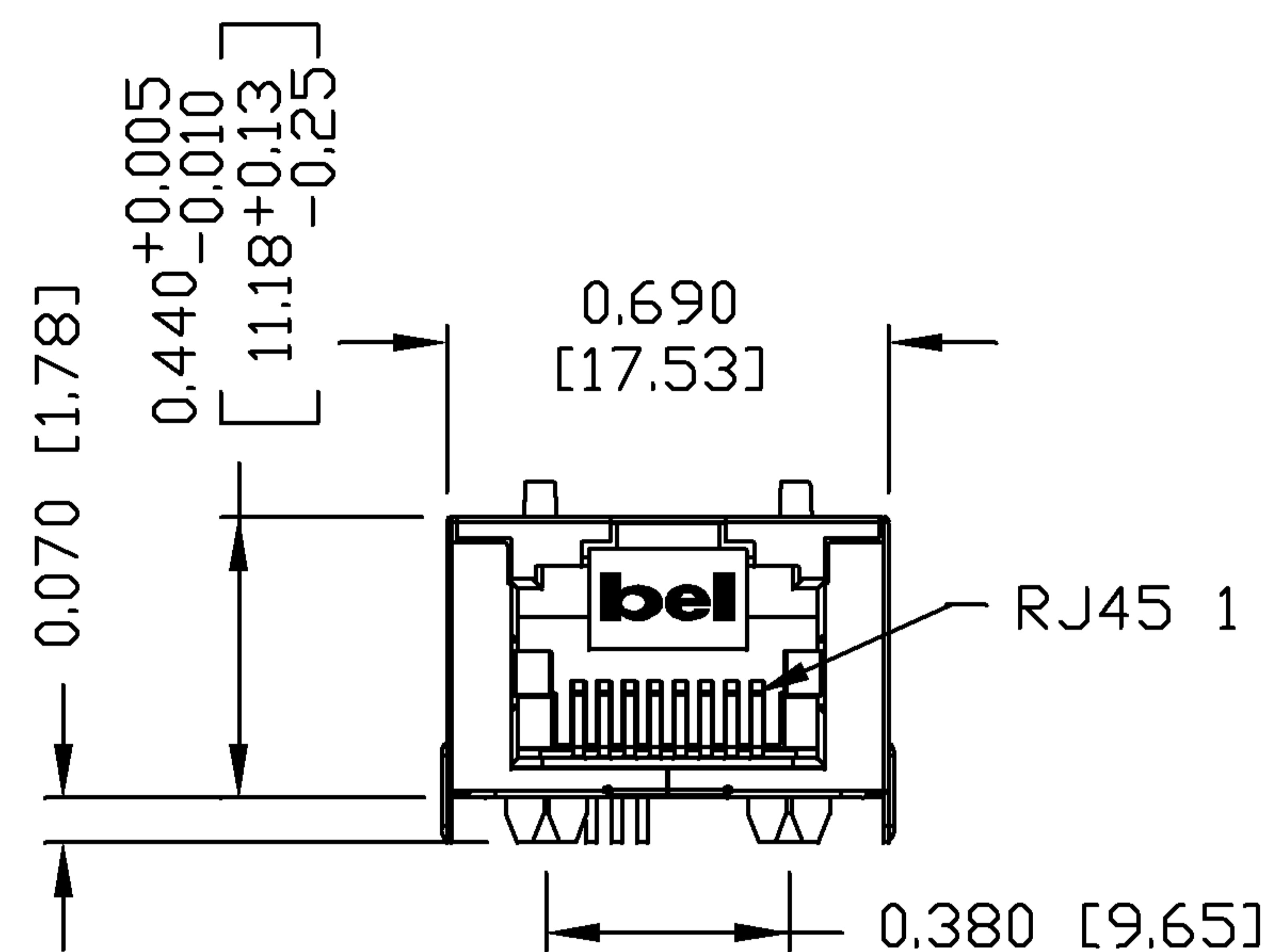

PRELIMINARY

RECOMMENDED PCB FOOTPRINT
COMPONENT SIDE VIEW

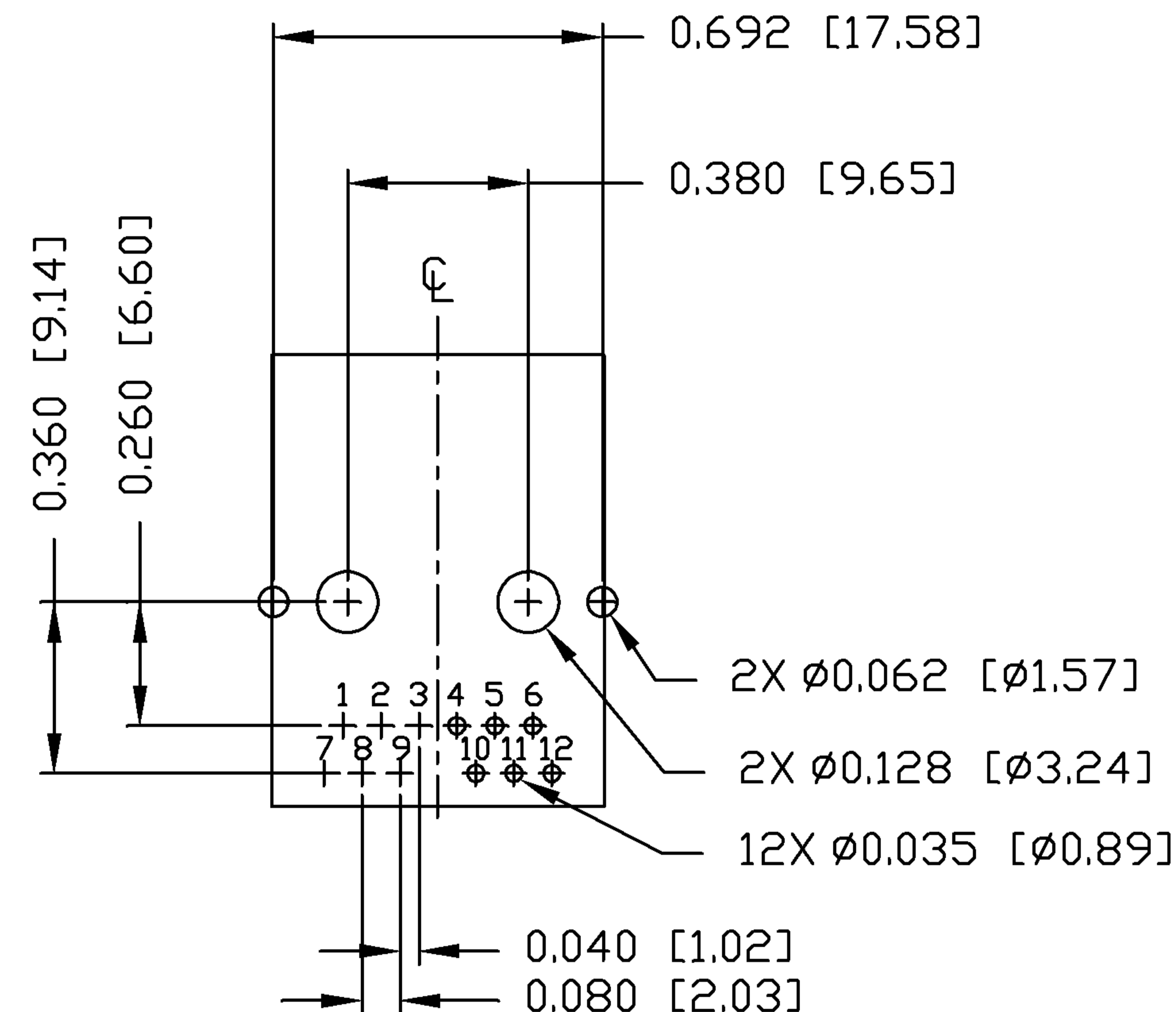

NOTES:

- PLASTIC HOUSING: THERMOPLASTIC PA, FLAMMABILITY RATING UL 94V-0
- CONTACTS: 30 MICRO-INCH HARD GOLD PLATING
- OUTPUT PINS: TIN-COATED COPPER WIRE, DIA 0.018 INCH.
- METAL SHIELD: NICKEL PLATED ON COPPER ALLOY.
- (ALL GROUND LEADS ARE SOLDER DIPPED)

RoHS COMPLIANT, PER EU DIRECTIVE 2002/95/EC.

[1] MARK PART WITH MFG. LOGO, MFG. NAME, PART NUMBER (L837-1X1C-06), AND DATE CODE.
JACK CAVITY CONFORMS TO FCC RULES AND REGULATIONS.

US UL RECOGNIZED - FILE #E196366 AND E169987.

| | | | | | | | |
|-----------------------------|------------------|---|--|-------------------------------|------------------------------|-----------|---|
| ORIGINATED BY ANTON LIAO | DATE 04-23-08 | TITLE 10/100 MagJack® (Ultra Low Profile) | PART NO. / DRAWING NO. L837-1X1C-06 | STANDARD DIM. TOL. IN INCH | [] METRIC DIM. AS REFERENCE | | COMPONENTS FOR A CONNECTED PLANET |
| DRAWN BY CHEN TING | DATE 04-23-08 | | FILE NAME L837-1X1C-06_PA.DWG | .X | UNIT : INCH [mm] | REV. : PA | |
| | | | | .XX | SCALE : N/A | SIZE : A4 | |
| | | | .XXX | ±0.010 | PAGE : 3 | | |

THE INFORMATION CONTAINED HEREIN IS CONSIDERED "PROPRIETARY" TO BEL FUSE INC. AND SHALL NOT BE COPIED, REPRODUCED OR DISCLOSED WITHOUT THE WRITTEN APPROVAL OF BEL FUSE INC.

SUGGESTED PANEL OPENING

PRELIMINARY

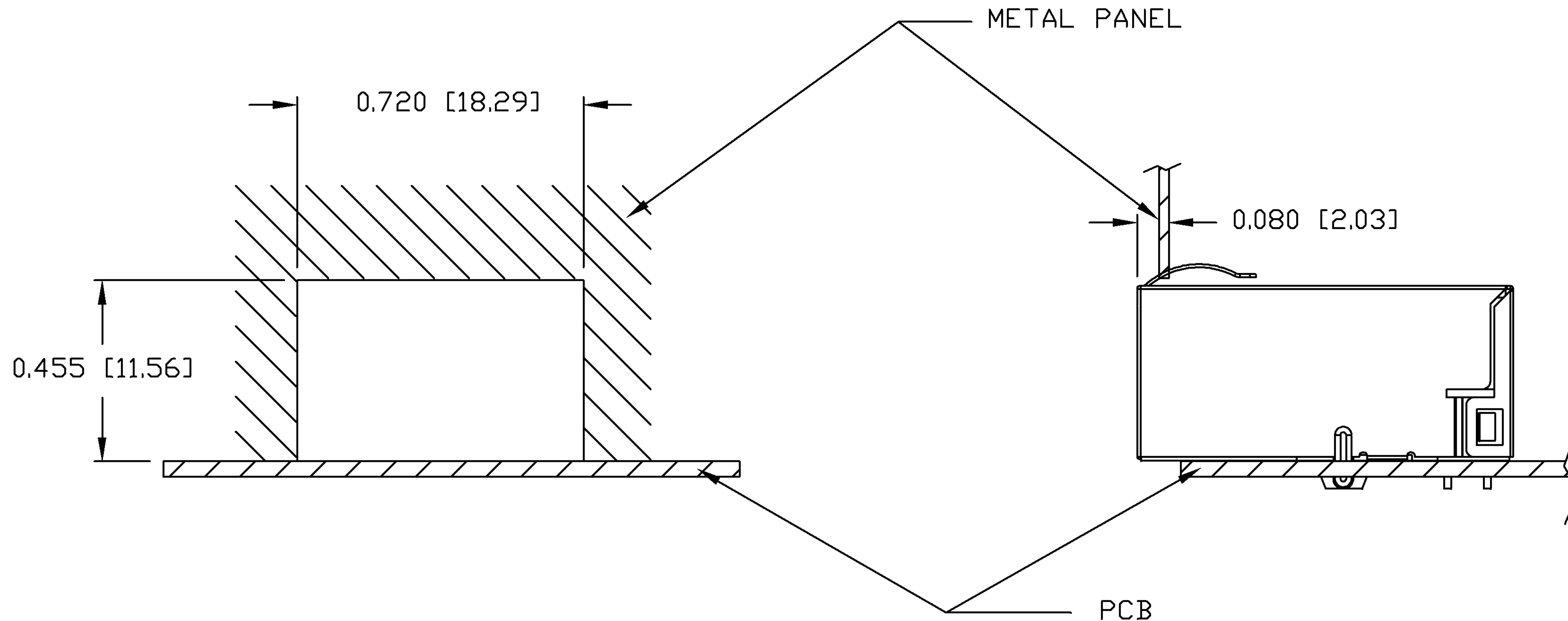
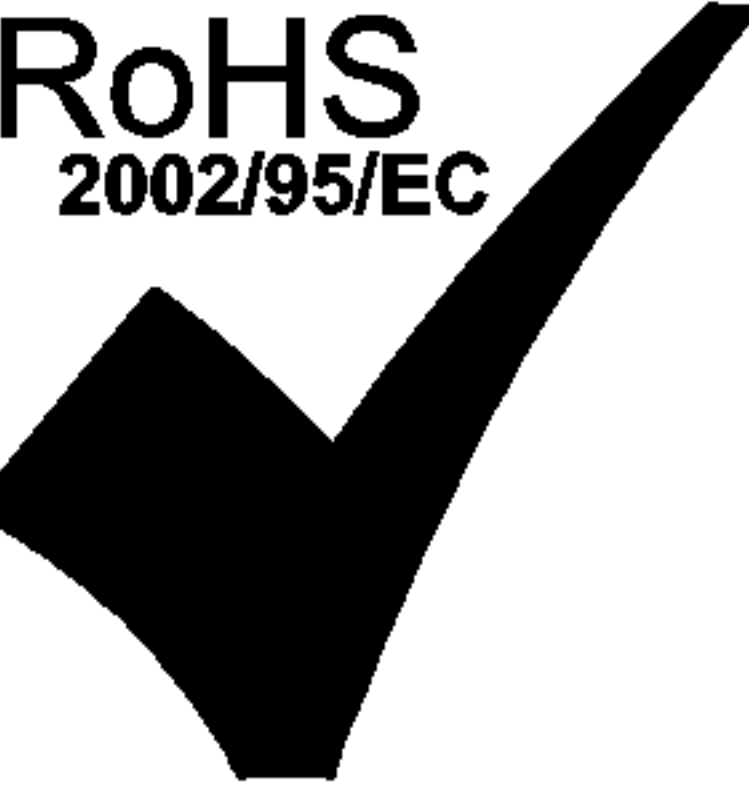

NOTE:

THE DISTANCE OF PANEL INSIDE SURFACE RELATIVE TO FRONT SURFACE OF PART IS ONLY A SUGGESTION. IN CASE THIS DISTANCE IS DIFFERENT, THE REQUIRED PANEL OPENING DIMENSIONS CHANGE ACCORDINGLY.

TRAY PACKING INFORMATION

PACKING TRAY : 0200-9999-E4 (TOP)

0200-9999-E5 (BOTTOM)

PACKING QUANTITY : 60 PCS FINISHED GOODS PER TRAY

11 TRAYS (660 PCS FINISHED GOODS) PER CARTON BOX

NOTE : CARDBOARDS ARE PLACED BETWEEN LAYERS OF PACKING TRAY INSIDE CARTON BOX
(INCLUDE THE UPPERMOST AND LOWERMOST TRAY)

| | | | | | | | | | |
|------------------------------------|-------------------------|--|---|-----------|-----------------------------------|-------------|-------------------------------------|-------------------------|---------------------------------------|
| ORIGINATED BY ANTON LIAO | DATE 04-23-08 | TITLE 10/100 MagJack® (Ultra Low Profile) | PART NO. / DRAWING NO. L837-1X1C-06 | | STANDARD DIM. TOL. IN INCH | | [] METRIC DIM. AS REFERENCE | | COMPONENTS FOR A CONNECTED PLANET |
| DRAWN BY CHEN TING | DATE 04-23-08 | | FILE NAME L837-1X1C-06_PA.DWG | .X | .XX | .XXX | ±0.004 | UNIT : INCH [mm] | |
| | | | | | | | SCALE : N/A | SIZE : A4 | |
| | | | | | | | | PAGE : 4 | |