

P:\Projects\Projects in R&D Status\InTal Tech\IN09 Backshell for Micro D-Type\IN09-DS-16-C 21/05/2012

ZONE	REV.	DESCRIPTION	DATE	APPROVED
	B	RELEASED	15/11/2010	IGOR
	C	ADD PANEL 2.5mm KIT	30/05/2011	IGOR

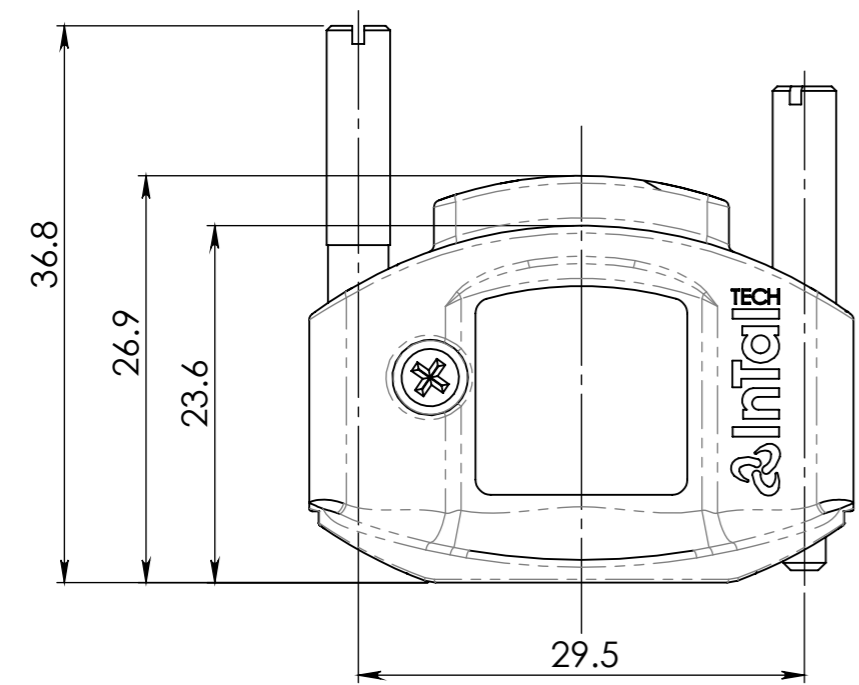
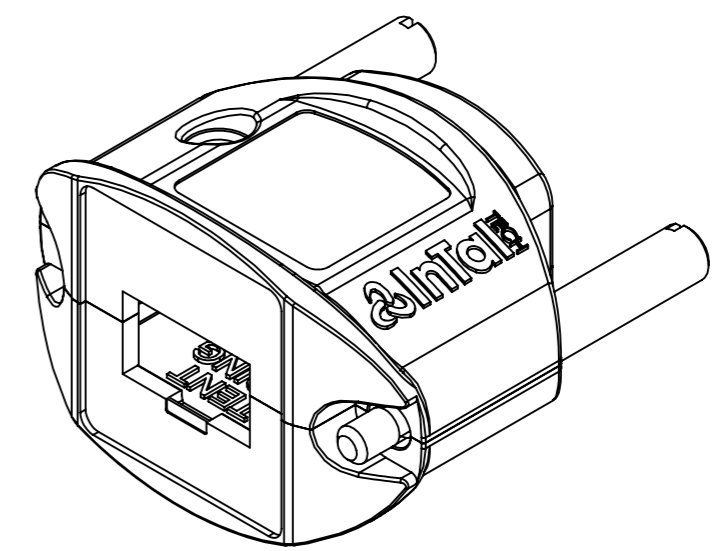
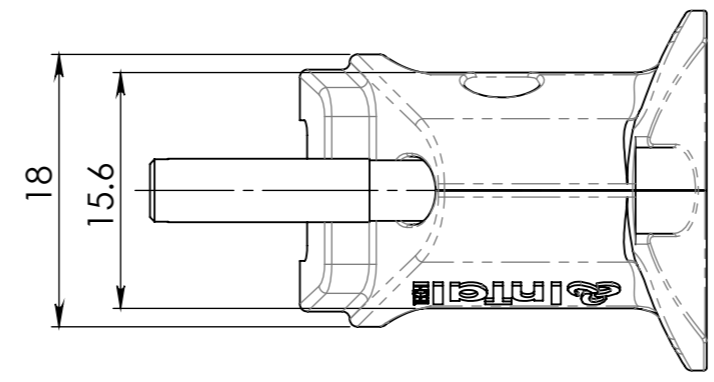
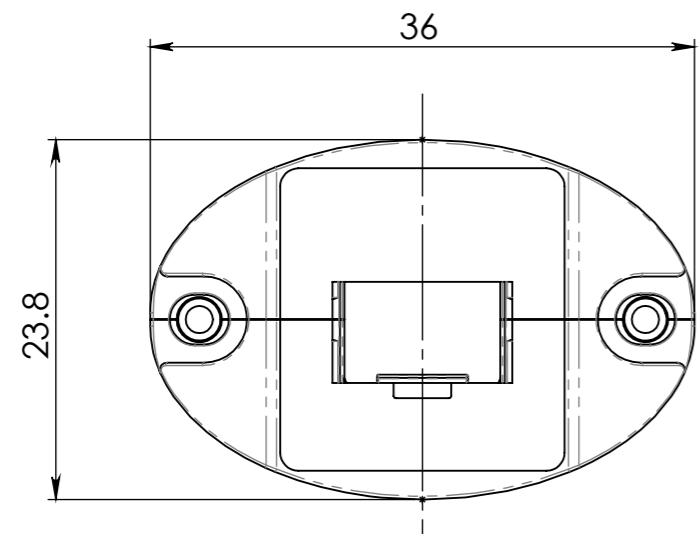

P/N	MATERIAL
IN09-KT-16	BLACK POLYAMIDE PA6, UL94, V-0
IN09-KT-29	WHITE POLYAMIDE PA6, UL94, V-0

NOTE:

MATERIAL:

1. PLASTIC HOOD - SEE TABLE
2. FASTENING - #4-40UNC JACK SCREW - STAINLESS STEEL
3. SCREW FOR PLASTIC - STEEL, BLACK PASSIVATION

TOLERANCES UNLESS OTHERWISE STATED			MATERIAL:	FINISH:		
LINEAR ±	HOLES DIA +					
ANGULAR ±	MASH. SURF'S					
	NAME	SIGNATURE	DATE	TITLE		
DRAWN	ELENA			<b>KIT,RJ45 PLASTIC BACKSHELL, HORIZONTAL DATA SHEET</b>		
DES'N'D	GREGORY			PROJECT		
CHK'D				PART. NO. SEE TABLE		
APP'V'D				VERSION		
THIS DOCUMENT CONTAINS PROPRIETARY INFORMATION AND SHALL NOT BE PUBLISHED OR USED FOR ANY PURPOSE WITHOUT THE PRIOR WRITTEN PERMISSION OF INTALTECH Ltd. DO NOT MANUALLY UPDATE. DO NOT SCALE DRAWING.		Engineering Development & Consulting		DWG NO.	REV.	SHEET
				<b>IN09-DS-16-C</b>	C	1/2
				SIZE A3	FIRST ANGLE PROJECTION	DIM UNIT MM

P:\Projects\Projects in R&D Status\InTal Tech\IN09 Backshell for Micro D-Type\0 IN09\IN09-DS-16-C 21/05/2012

### CABLE MOUNTING PANEL CUTOUT

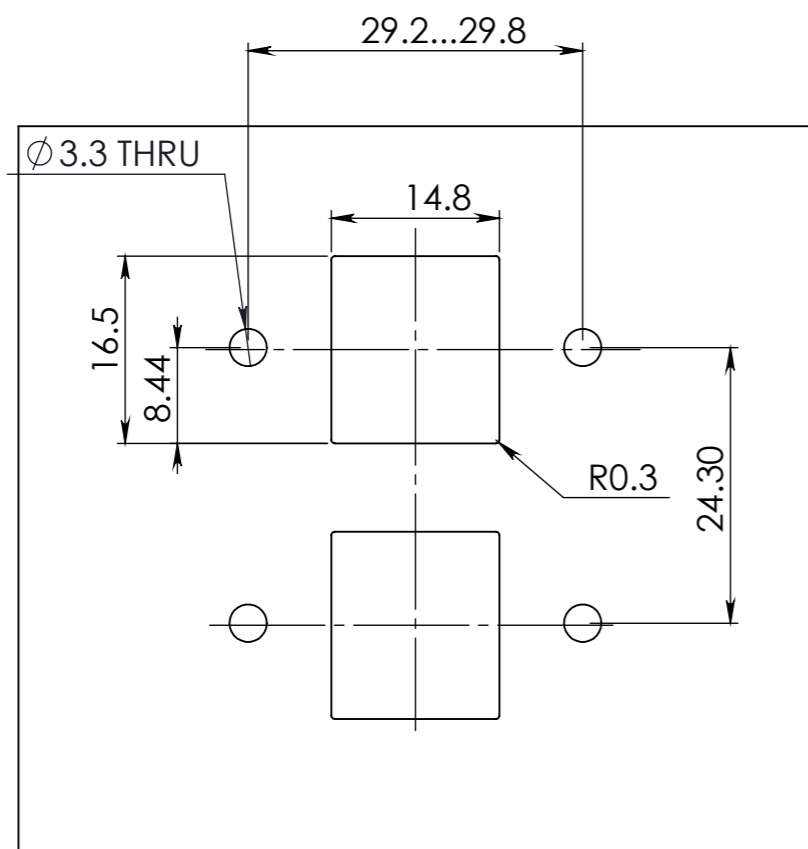

△ C

KIT, RJ45 PANEL, HORIZONTAL  
P/N: IN09-KT-18 FOR 1.5 mm PANEL,  
P/N: IN09-KT-22 FOR 2.5 mm PANEL  
**TO BE ORDERED SEPARATELY**

SPACER  
MALE-FEMALE #4-40x3/16  
P/N: HSO0404HH0  
**TO BE ORDERED SEPARATELY**  
QTY.x 2

ENVIROMENTAL GASKET  
P/N: IN09-PF-64  
**TO BE ORDERED SEPARATELY**

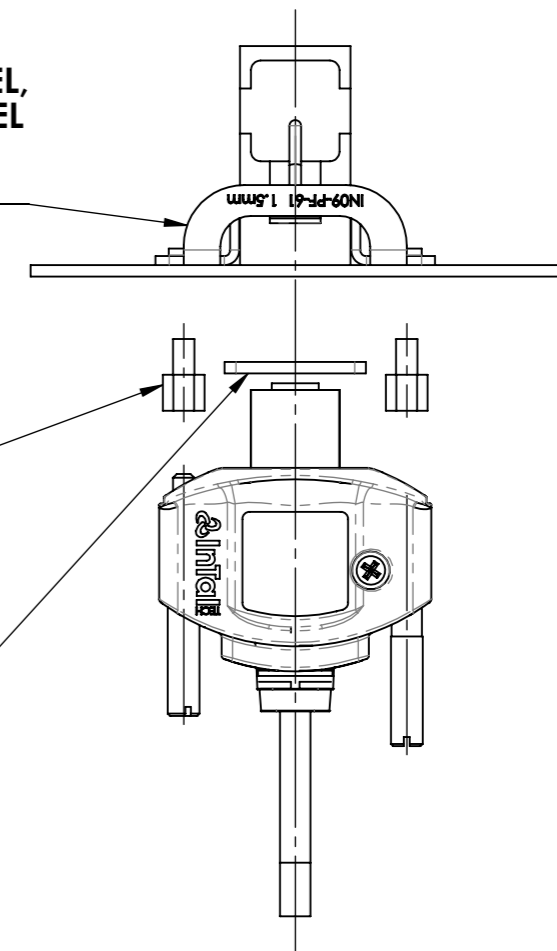

<p>THIS DOCUMENT CONTAINS PROPRIETARY INFORMATION AND SHALL NOT BE PUBLISHED OR USED FOR ANY PURPOSE WITHOUT THE PRIOR WRITTEN PERMISSION OF A&amp;J. DO NOT MANUALLY UPDATE. DO NOT SCALE DRAWING.</p>	<p>Engineering Development &amp; Consulting</p>	PART. NO. IN09-KT-16		VERSION	
		DWG NO. <b>IN09-DS-16-C</b>		REV. C	SHEET 2/2
		SIZE A3	FIRST ANGLE PROJECTION	DIM UNIT MM	SCALE 1.5:1