

1	2	3	4	5	6	7	8
ZONE	REV.	DESCRIPTION		DATE	APPROVED		
	A	RELEASED		26/01/2010	IGOR		

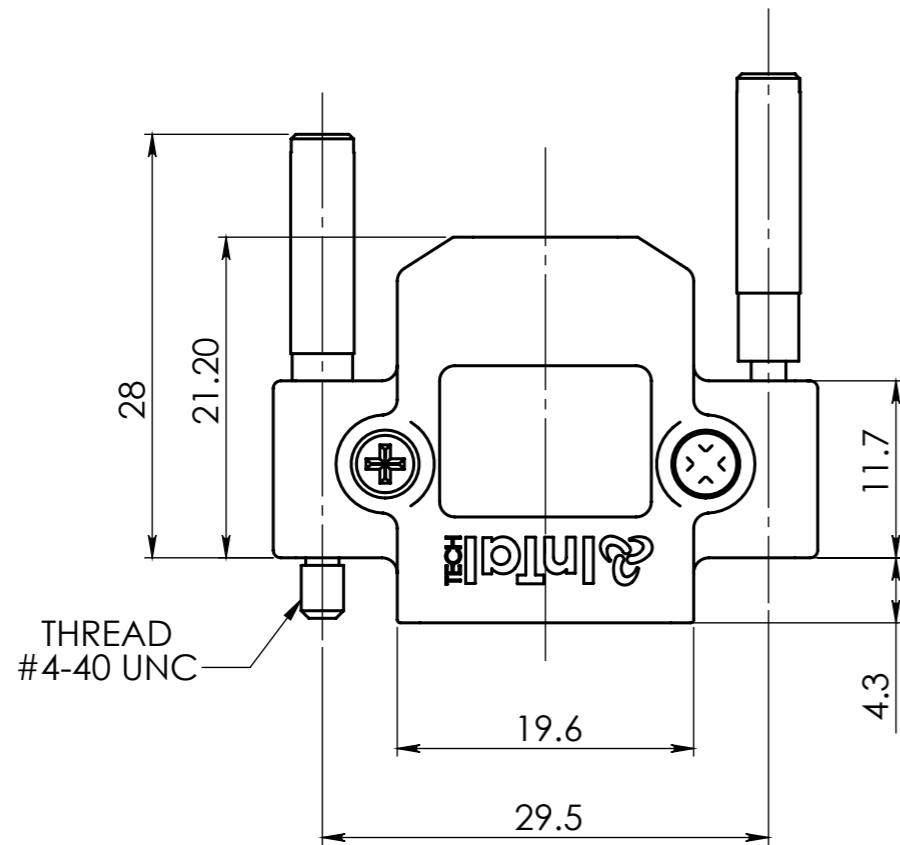
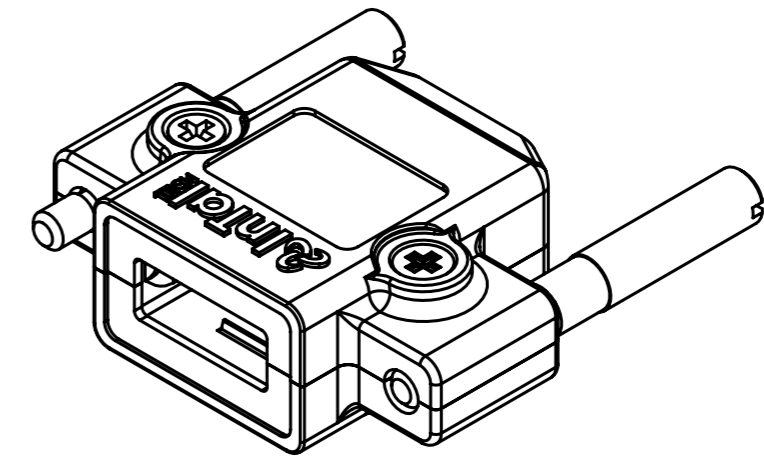
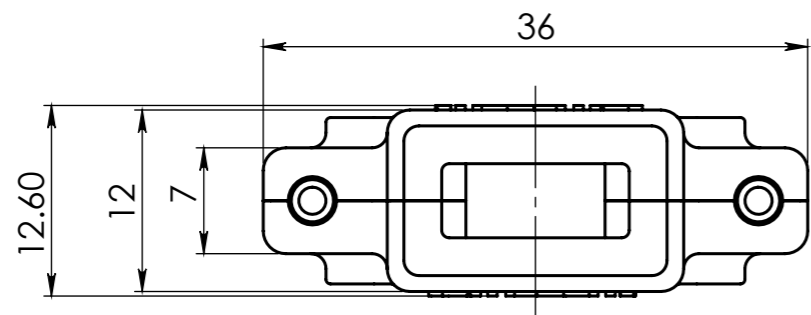

NOTE:

- FOR P/N DESCRIPTION OF USB A FEM CONNECTOR PLEASE CONTACT InTaltech ENGINEERING/SALES DEPARTMENT
- PLASTIC HOOD - BLACK POLYAMIDE PA6, UL94, V-0
- FASTENING - #4-40UNC JACK SCREW - STAINLESS STEEL
- SCREW FOR PLASTIC - STEEL, BLACK PASSIVATION

TOLERANCES UNLESS OTHERWISE STATED				MATERIAL:	FINISH:				
LINEAR	±	HOLES DIA	+						
ANGULAR	±	MASH. SURF'S							
	NAME	SIGNATURE	DATE	TITLE					
DRAWN	ELENA			USB A PLUG PLASTIC BACKSHELL KIT DATA SHEET					
DESND	GREGORY								
CHK'D				PROJECT					
APPV'D				PART. NO. IN09-KT-11					
THIS DOCUMENT CONTAINS PROPRIETARY INFORMATION AND SHALL NOT BE PUBLISHED OR USED FOR ANY PURPOSE WITHOUT THE PRIOR WRITTEN PERMISSION OF INTALTECH Ltd. DO NOT MANUALLY UPDATE. DO NOT SCALE DRAWING.				 Engineering Development & Consulting		DWG NO. IN09-DS-11-A		REV. A	SHEET 1/2
						SIZE A3	FIRST ANGLE PROJECTION	DIM UNIT MM	SCALE 2:1

P:\Projects\Projects in R&D Status\InTal Tech\IN09 Backshell for Micro D-Type\IN09-DS-11-A 21/05/2012

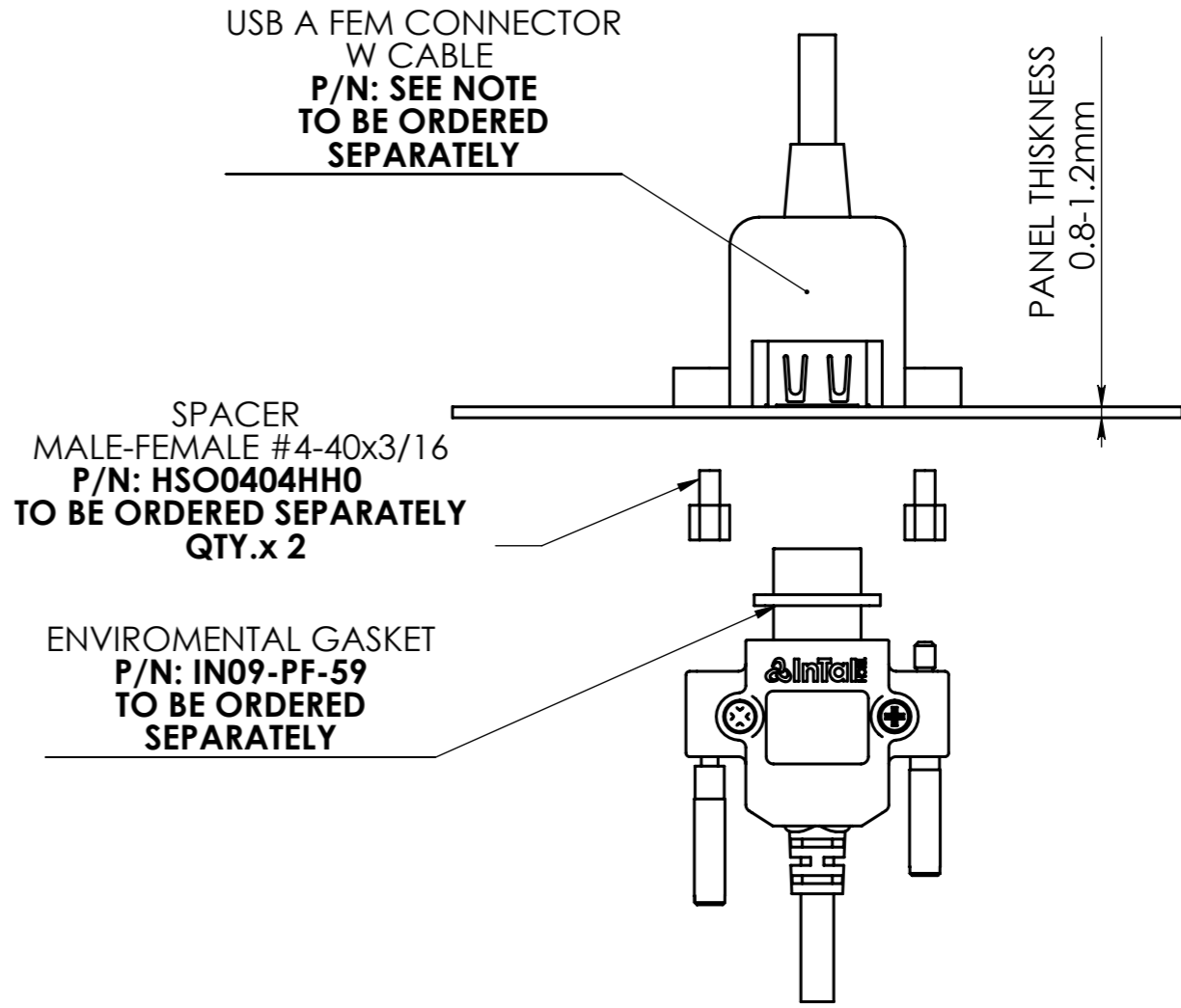
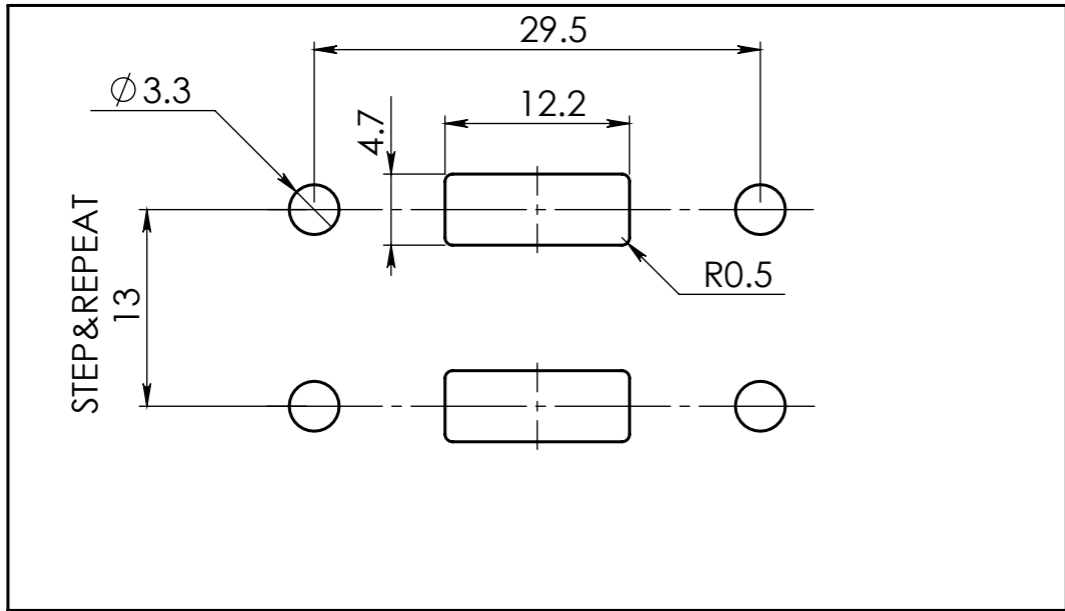

THIS DOCUMENT CONTAINS PROPRIETARY INFORMATION AND SHALL NOT BE PUBLISHED OR USED FOR ANY PURPOSE WITHOUT THE PRIOR WRITTEN PERMISSION OF A&J. DO NOT MANUALLY UPDATE. DO NOT SCALE DRAWING.	 Engineering Development & Consulting	PART. NO. IN09-KT-11		VERSION	
		DWG NO. IN09-DS-11-A		REV. A	SHEET 2/2
		SIZE A3	FIRST ANGLE PROJECTION	DIM UNIT MM	SCALE 2:1