

RELEASED DATA SHEET

UPF105 Series Universal Input Power Factor Corrected 120 Watt Switchers

Features:

- Active Power Factor Correction (PFC)
- 75% typical efficiency
- EN55022-B conducted
- Up to 4 outputs
- Compact 6.0" x 3.3" x 1.4" size
- UL, cUL, VDE and CE
- CB Test Certificate and Report
- Optional cover



The UPF105 series are economical, high efficiency open frame switchers that deliver up to 120W continuous or 130W peak power from one to four outputs. The supply includes active power factor correction and 90-250Vac universal input, making it ideal for use worldwide.

The UPF105 is one of the *flexibility* series. In addition to the models listed on this sheet, many potential models are available that include full safety agency approval and do not require any non-recurring engineering (NRE) charge. Prototype delivery is just a few weeks.

Flexibility options include a cover. Output voltage options are given in the table below. Fully custom models are also available. Contact the factory for details.

This 120W series is also available without power factor correction (US100) and with dc input (DP100). These two products are 100W series and are slightly smaller than the UPF105.

Specifications are subject to change without prior notice.

Available models

Model Number	Output	Output Voltage	Output Current Ratings			
			Min ¹	Max ²	Max ³ (I _m)	Peak ⁴
UPF105-105	V1	+5V	0A	12A	16A	20A
UPF105-124	V1	+24V	0A	3.3A	5A	5.4A
UPF105-148	V1	+48V	0A	1.6A	2.5A	2.7A
UPF105-230	V1	+3.3V	0A	10A	16A	20A
	V2	+5V	0A	5A	7A	8A
UPF105-301	V1	+5V	0A	8A	10A	12A
	V2	+12V	0A	3A	6A	7A
	V3	-12V	0A	1A	2A	3A
UPF105-401	V1	+5V	0A	8A	10A	12A
	V2	+12V	0A	3A	6A	7A
	V3	-12V	0A	1A	2A	3A
	V4	-5V	0A	1A	2A	3A
UPF105-405	V1	+3.3V	0A	12A	15A	18A
	V2	+15V	0A	1A	2A	3A
	V3	+24V	0A	1A	2A	2.5A
	V4	+5V	0A	2A	5A	6A

UPF105-408	V1	+5V	0A	10A	13A	15A
	V2	-15V	0A	1A	2A	2.5A
	V3	+15V	0A	1A	2A	2.5A
	V4	+24V	0A	0.5A	1A	1.5A
Modified standard flexibility options ⁵	V1	± 2.5 to $\pm 48V^6$		12A	16A	
	V2	± 2 to $\pm 48V^7$		4A	7A	
	V3	± 2 to $\pm 48V^7$		2A	5A	
	V4	± 2 to $\pm 48V^7$		2A	5A	

Notes:

1. At least 20% of maximum output current (I_m) is required to maintain stated regulation. Supply remains on at zero load, but regulation is not guaranteed.
2. Convection cooling, 80W maximum⁹
3. Forced air cooling, 120W maximum⁹
4. Peak output, no post regulation, 30 sec max
5. The UPF105 series allows very fast *flexible* modified standard designs within these parameters without non-recurring engineering charges and while retaining safety agency approvals. Please contact the factory for details.
6. Can be specified in 0.1V increments
7. Can be specified in 0.75V increments
8. Operational extremes per safety agency testing
9. Cooling requirements may differ between models; contact the factory for details.
10. With optional post regulation on V4

Specifications

Specifications are typical at 25°C unless otherwise designated.

Parameter	Limits
Input	
Input Voltage Range	90-250Vac rated 81-265Vac operation ⁸
Input Frequency	47 to 63Hz
Input Operating Current	2A rms @ 90Vac input, 120W output
Input Surge Current	25A max, cold start @ 25°C, 250Vac
Efficiency	75% typ @ 115Vac input, full power
Power Factor	0.98 typ @ 230Vac input, 120W output
Output	
Output Power	80W, natural convection cooling ⁹ 120W, forced air cooling ⁹ 130W peak
Line Regulation	$\pm 0.5\%$, V_{in} (min) to V_{in} (max)
Load Regulation	$\pm 1\%$ (V1, 20% to 100% I_m) $\pm 5\%$ (V2, V3, V4, 20% to 100% I_m) $\pm 1\%$ (V4, 20% to 100% I_m for $I_4 \leq 5A$ and $V_4 \leq 24V$) ¹⁰

Cross Regulation	±0.5% (V1, 20% to 100% I _m on V2–V4) ±5% (V2, V3, V4, 20% to 100% I _m on V1) ±1% (V4, 20% to 100% I _m on V1-V3, with I ₄ ≤ 5A and V ₄ ≤ 24V) ¹⁰
Noise and Ripple	25mV max RMS, 50mV max P-P, on V1=5.0V with full load 0.5% max RMS, 1% max P-P, on V2, V3, V4 with full load
Power-up Overshoot	5% max, all outputs
Transient Response	V ₁ , for 25% to 75% I _m change, 5% max deviation, with recovery to 1% within 500μS
Hold-up Time	16mS min @ 115Vac input, 120W output
Overvoltage Protection Threshold	125% typical of V _{out} , all outputs
Power Limit Point	125% typical of max rated power
Environmental	
Operating Temperature Range (full power)	0°C to +50°C
Operating Temperature Range (extended range)	0°C to +70°C Derate linearly from full power at +50°C to half power at +70°C
Storage Temperature Range	-25°C to +85°C
Relative Humidity Range	5% to 95%, non-condensing
Vibration	0.75G peak, 5Hz to 500Hz. Test three orthogonal axis at 1 octave/min, 5 min dwell at four major resonances
MTBF	180,000 hours typical calculated per MIL STD 217 F, at 30°C ambient
Weight	1.12 lb. (0.51 kg)

INPUT VOLT:	FREQUENCY:	MAX. INPUT CURRENT:	PHASE:	PFMR FACTOR COR.:
90-250VAC	47-63Hz	1.5 AMPS	SINGLE >0.8 @ P _o = 100W	

REVISIONS				DATE	APPROVED
E.C.N.	ZONE	LTR	DESCRIPTION	DATE	APPROVED
05-07	—	A	CHANGE TRANSFORMER GATE P/N	01/15/05	LD
06-10	—	B	UPDATE DRAWING ROUNDS	04/05/06	LD
07-21	—	C	CHANGE WIRE P/N ON TRANSFORMER	02/20/07	LD

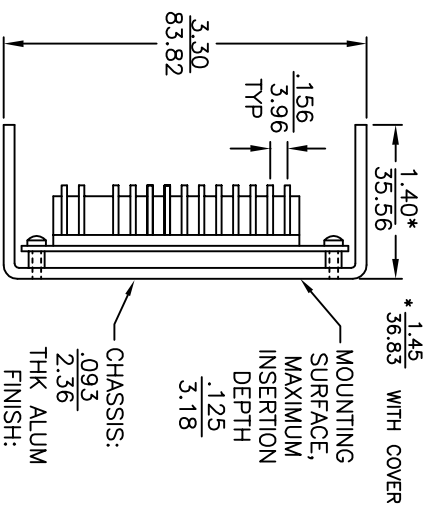
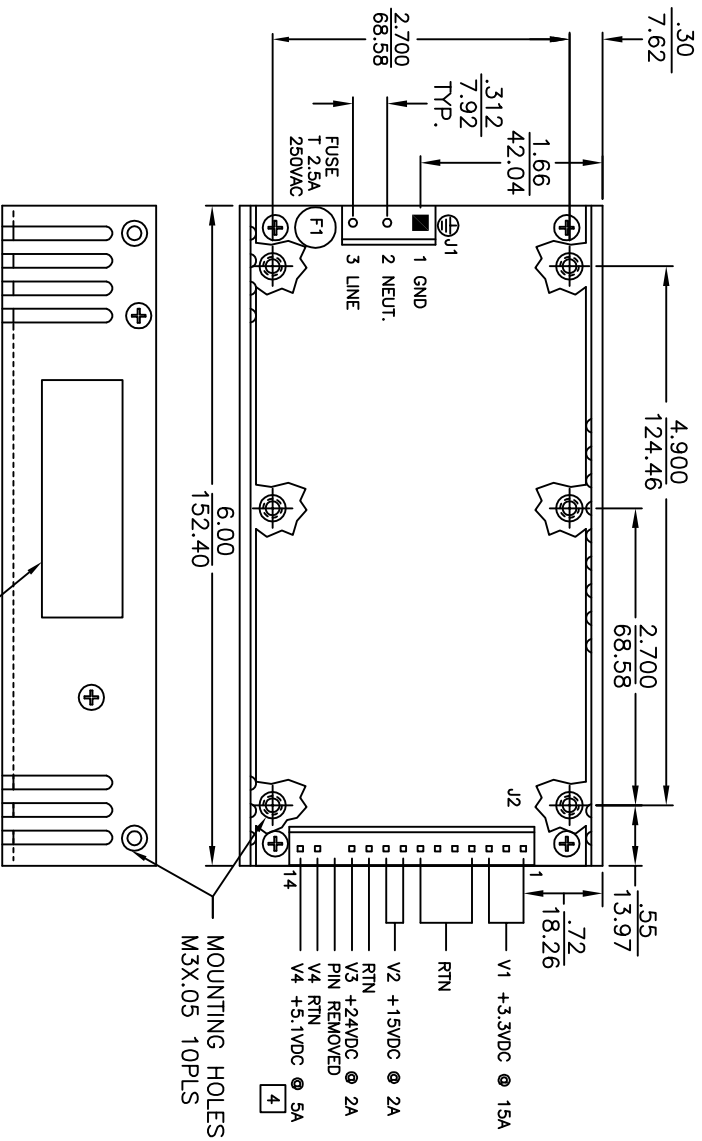

DIMENSIONS

INCHES TOLERANCE
 .XX ± .03 / 0.78 mm
 MM .XXX ± .015 / 0.381 mm

4. VA: FLOATING OUTPUT ON SOME MODELS.
 3. ALL RETURNS (RTN) ARE COMMON.
 2. J1 CONNECTOR = MOLEX INC. 41671 SERIES, P/N: 26-48-1055, (MATING CONNECTOR = MOLEX INC. 2139 SERIES, P/N: 08-50-3051).
 J2 CONNECTOR = MOLEX INC. 41671 SERIES, P/N: 26-48-1145, (MATING CONNECTOR = MOLEX INC. 2139-SERIES, P/N: 08-50-314).
 ALL MATING CONNECTOR TERMINALS = MOLEX INC. 6838 SERIES, P/N: 08-52-0113.

1. SHIPPED READY FOR 115 OR 230VAC INPUT.
 NOTES: UNLESS OTHERWISE SPECIFIED.

UNLESS OTHERWISE SPECIFIED DIMENSIONS ARE IN INCHES FRACTIONS DECIMALS ANGLES .XX ± .03 .XXX ± .015		CONTRACT NO.		DATE	
DRAWN: L.ORTIGA		APPROVALS:		01/15/05	
CHECKED: D.ASHTON		PROGRAM: AUTOCAD LT.05		02/20/07	
D.ASHTON		FILE: REV.C		02/23/07	
SCALE: NONE		SIZE: B		CODE IDENT NO.	
NEXT ASSY		APPLICATION		USED ON	
100 WATT POWER SUPPLY		UPFS105-405		REV C	

DIGITAL POWER CORPORATION
 41920 CHRISTY ST. FREMONT, CA 94538-3158
 PHONE: (510) 657-2635 FAX: (510) 657-6634

OUTLINE DRAWING

A B C D 4 3 2 1

A B C D 1 2 3 4