



The Gresham Power PS-1138 is a high-power module designed for use in MicroTCA systems. It supports shelves, cubes, MicroTCA enclosures, and other implementations and complies with the PICMG MicroTCA Revision 1.0 specification.

The PS-1138 provides functionality for powering, managing, and protecting a MicroTCA system that includes up to 12 Advanced MCs, 2 MicroTCA carrier hubs, and 2 cooling units.

Key Features

- 600W output power
- 16 channels of 12V @ 7.6A; 16 channels of 3.3V @ 150mA
- Hot swappable N+1 output redundancy
- Monitors and reports power system status
- Manages and isolates faults affecting the power system
- Provides protection against overload, short circuit, over voltage, and over temperature
- Provides power necessary for MCH and CU system elements on system bring-up
- Supports redundant IPMI (IPMB-0) communication with the MCH/carrier-manager
- Enables and provides power to AMCs, CUs, and additional MCHs
- Includes an Enhanced Module Management Controller using two IPMBs (IPMB-A and IPMB-B)
- Meets Class B conducted emission standards
- Compliant with MicroTCA chassis standard

Input

- Input voltage: 90 – 264 VAC, 50/60Hz
- Power factor: 0.99 typical
- Efficiency: > 90%
- Hold-up Time: 10 ms minimum at 600W
- Inrush current: ≤ 35A

12V Output (Payload Power)

- Total regulation range:
12.25 to 12.95 VDC when configured as primary PM
11.60 to 12.00 VDC when configured as redundant PM
- Setpoint:
12.6 VDC typical when configured as primary PM
11.8 VDC typical when configured as redundant PM
- Ripple and noise: 100mV maximum V p-p at 0 to 20MHz oscilloscope bandwidth, measured with 0.1uF ceramic and 10uF tantalum capacitor on any output
- Short circuit protection: 9.7A maximum within 10ms auto recovery, over 10ms latch shut down
- Charge capacity per channel: 25ms maximum with 1600uF on output under test

3.3V Output (Management Power)

- Total regulation range: 3.16 to 3.63 VDC
- Setpoint: 3.3 VDC typical
- Ripple and noise: 50mV maximum V p-p at 0 to 20MHz oscilloscope bandwidth, measured with 0.1uF ceramic and 10uF tantalum capacitor on any output
- Short circuit protection: 225mA maximum within 12ms auto recovery, over 12ms latch shut down
- Charge capacity per channel: 25ms maximum with 150uF on output under test

Environmental Conditions

- Operating temperature: -10°C to 55°C full load with 300 LFM forced air cooling
- Storage temperature: -40°C to 85°C
- Vibration: Random vibration, 10Hz to 500Hz, 3 axis 1.9 GRMS maximum
- Shock: Peak acceleration 1GPK maximum

Safety Standards

- UL, cUL 60950-1 • CSA 60950-1 • VDE 60950-1

Output Voltages & Currents

Output	Output Voltage	Minimum Load	Total Maximum Load	Maximum per Channel
V1	16 x 12 VDC	0	588 W @ 49A	80 W / 7.6A
V2	16 x 3.3 VDC	0	12.5W @ 3.8A	0.5W / 150mA

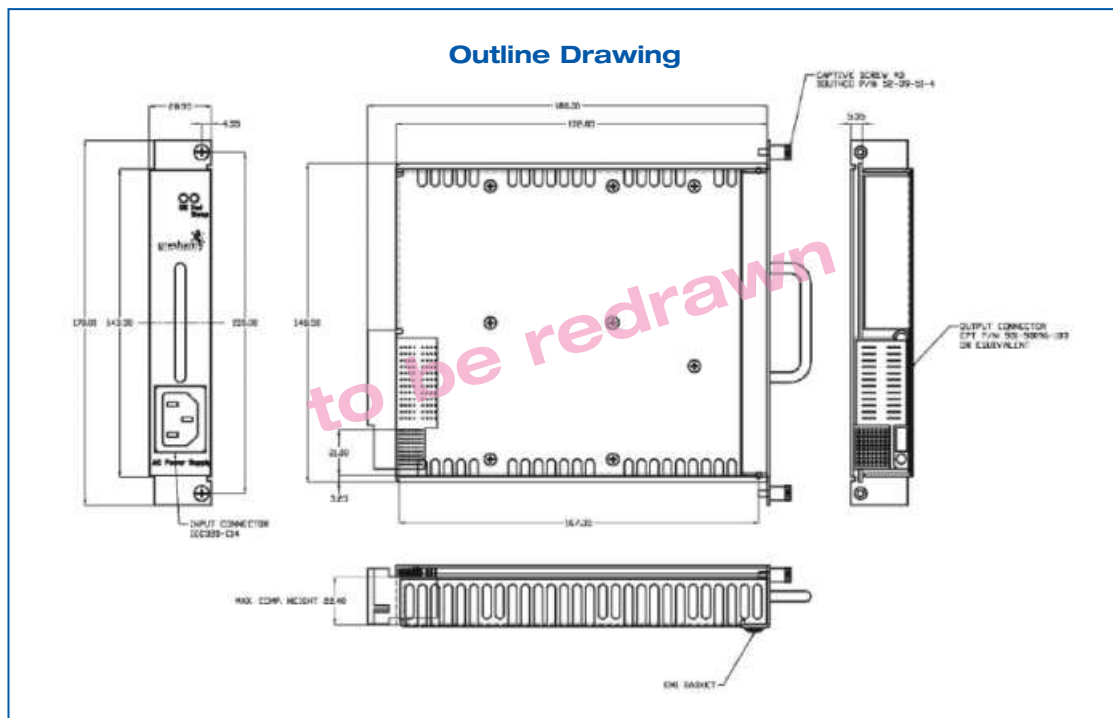

All specifications are subject to change without notice