



Part Number	DESC Drawing Number	Relay Description
652-1	M28750/10-001	25A, 250Vrms, AC Solid State Relay
652-2	M28750/10-002	25A, 250Vrms, AC Solid State Relay

The Y suffix denotes parameters tested to MIL-PRF-28750 specifications.
The W suffix denotes parameters tested to Teledyne Specifications.

ELECTRICAL SPECIFICATIONS

(-55°C to +110°C CASE TEMPERATURE, UNLESS OTHERWISE NOTED)

INPUT (CONTROL) SPECIFICATIONS

	Min	Typ	Max	Unit
Input Current (See Figure 1) $V_{IN} = 5 \text{ Vdc}$		10	15	mA
$V_{IN} = 5 \text{ Vdc}$		11	16	mA
Turn-Off Voltage (Guaranteed Off)			1.0	Vdc
Turn-On Voltage (Guaranteed On)	4			Vdc
Reverse Voltage Protection			-32	Vdc
Input Voltage Range	4		32	Vdc

OUTPUT (LOAD) SPECIFICATIONS

	Min	Typ	Max	Unit
Output Current Rating (See Figure 2 & 3)			25	Arms
Output Voltage Rating	25		250	Vrms
Frequency Range	45		440	Hz
Output Voltage Drop @ 25 Ampere			1.5	Vrms
Off-State Leakage Current (250 Vac, 400 Hz)			10	mArms
Turn-On Time			1/2	Cycle
Turn-Off Time			1	Cycle
Transient Voltage ($T \leq 5 \text{ s}$)			± 500	Vpk
Overload Current (for 1 second)			80	Arms
DC Offset Voltage			± 150	mV
Zero Voltage Turn-On Point				
652-1			± 15	Vpk
652-2			± 40	Vpk
dv/dt (See Note 1)	200	400		V/ μs
Insulation Resistance @ 500 Vdc	10^8			Ohms

FEATURES/BENEFITS

- Qualified to MIL-PRF-28750
- Optical Isolation
- Zero voltage turn-on
- Zero current turn-off
- Logic compatible input
- Available to W or Y screening levels

DESCRIPTION

The Series 652 is an AC output solid-state relay designed for power switching. This relay incorporates a sealed, optically coupled solid state relay as a zero voltage turn-on driver. The input circuit is TTL logic compatible. Output switching is accomplished by back-to-back SCRs with a built-in snubber circuit, which provides reliable switching of both resistive and reactive loads with power factors as low as 0.2. The protected drive circuitry provides high transient immunity while reducing the commutation spike for low EMI. The 652 series is housed in a sealed aluminum case to withstand severe environmental conditions encountered in military and aerospace applications. These relays are qualified to MIL-PRF-28750/10 and are available to a W or Y screening level.

WIRING DIAGRAM

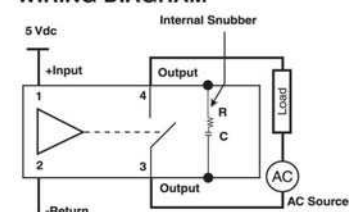

OUTPUT (LOAD) SPECIFICATIONS

	Min	Typ	Max	Unit
Dielectric Withstanding Voltage	1500			Vac
Power Dissipation			38	Watts
Thermal Resistance Junction to Ambient (θ_{JA})			10	°C/W
Thermal Resistance Junction to Case (θ_{JC})			1.2	°C/W

ENVIRONMENTAL SPECIFICATIONS

	Min	Typ	Max	Unit
Ambient Temperature Operating	-55		+110	°C
Storage	-55		+125	°C
Shock for 0.5 ms			1500	g
Vibration, 10 to 3000 Hz			30	g

* Contact factory for higher level environmental requirements

MECHANICAL SPECIFICATIONS

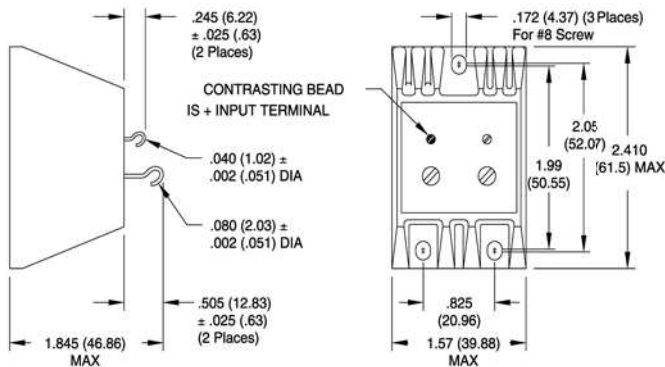

- Weight: 6 oz. max.
- Case Material:
Aluminum Nickel Plated

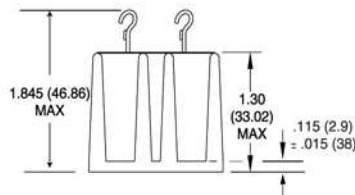

DIMENSIONS ARE SHOWN IN INCHES (MILLIMETERS)

NOTES

1. Output transient (dv/dt) protection is provided in all models. The dv/dt rating is based on a source impedance of 50 Ohms.
2. Case temperature measurement is point in center of mounting surface.
3. Designed to operate within all categories of MIL-STD-704B Aircraft Power Limits.
4. Designed to switch resistive or inductive load to 0.2 power factor.

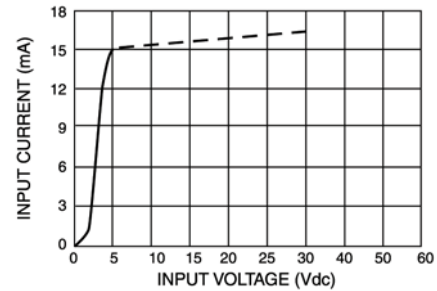

TYPICAL INPUT CURRENT VS INPUT VOLTAGE
FIGURE 1

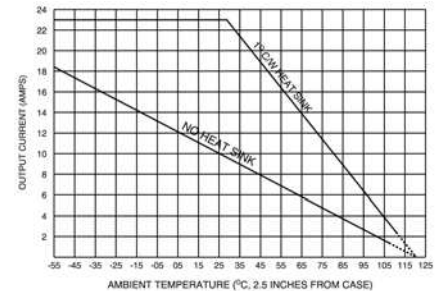

MAXIMUM ALLOWABLE CURRENT VS AMBIENT TEMPERATURE
FIGURE 2

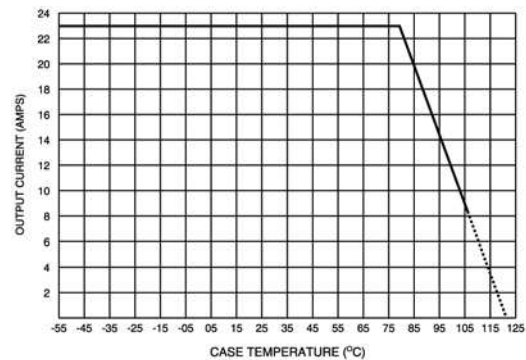

MAXIMUM ALLOWABLE CURRENT VS CASE TEMPERATURE
FIGURE 3 (See Note 2)