

● Features:

1. Chip material: GaAsP/GaP
2. Emitted color : Hi-Eff Red
3. Lens Appearance : Orange Diffused
4. Pulse Rate 2.4 Hz (VDD=5V)
5. Operating Voltage : 3V~12V (DC)
6. Easily be driven by TTL & C-MOS
circuit no external circuit needed
7. Long life solid state reliability.
8. This product don't contained restriction
substance, compliance ROHS standard.

● Applications:

1. TV set
2. Monitor
3. Telephone
4. Computer
5. Circuit board

● Package dimensions

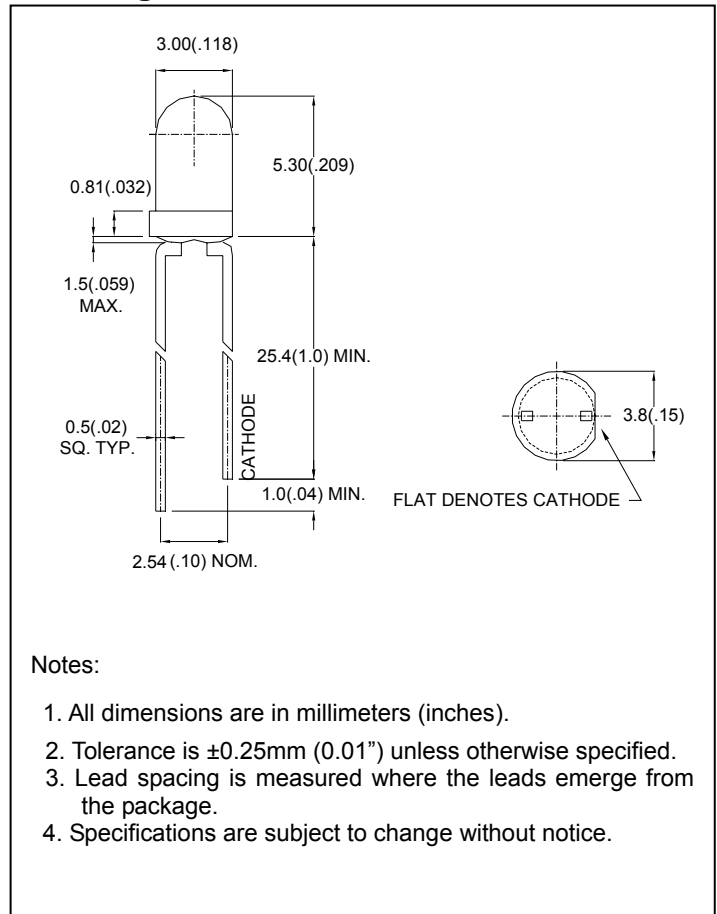

● Absolute maximum ratings(Ta=25°C)

Parameter	Symbol	Rating	Unit
Operating Voltage	V _O	12(max)	V
Reverse Voltage	V _R	5(max)	V
Operating Temperature	T _{opr}	-40°C~80°C	
Storage Temperature	T _{stg}	-40°C~85°C	
Soldering Temperature	T _{sol}	260°C(for 5 seconds)	

● Electrical and optical characteristics(Ta=25°C)

Parameter	Symbol	Condition	Min.	Typ.	Max.	Unit
Pulse Rate	Pd	VDD=5V	2.0	2.4	2.8	Hz
Luminous Intensity	Iv	I _F =20mA	-	25	-	mcd
Peak Wave Length	λ _p	I _F =20mA	-	640	-	nm
Dominant Wave Length	λ _d	I _F =20mA	617	-	638	nm
Spectral Line Half-width	Δλ	I _F =20mA	-	40	-	nm
Viewing Angle	2θ _{1/2}	I _F =20mA	-	50	-	deg

● Typical electro-optical characteristics curves

Fig.1 Relative intensity vs. Wavelength

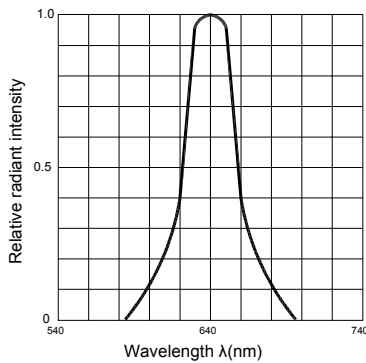

Fig.2 Forward current derating curve vs. Ambient temperature

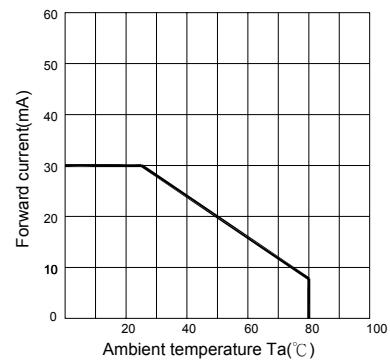

Fig.3 Forward current vs. Forward voltage

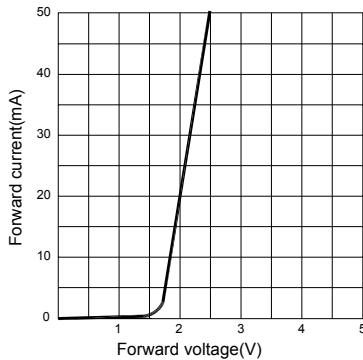

Fig.4 Relative luminous intensity vs. Ambient temperature

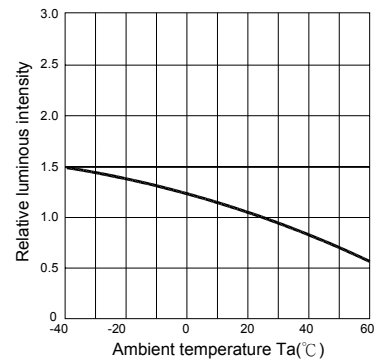

Fig.5 Relative luminous intensity vs. Forward current

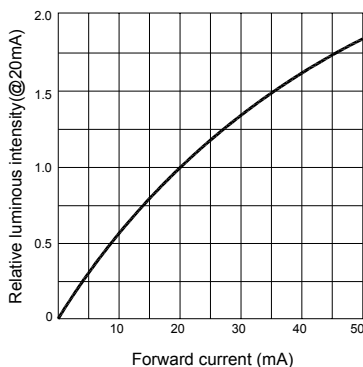

Fig.6 Radiation diagram

