

BRIGHT LED ELECTRONICS CORP.

●Device Number : BPT-BP0331

Page: 2

●Absolute Maximum Rating(Ta=25°C)

Version:1.0

Item	Symbol	Rating	Unit
Power Dissipation	Pd	100	mW
Collector-Emitter Voltage	V _{CEO}	30	V
Emitter-Collector Voltage	V _{ECO}	5	V
Operating Temperature	Topr	-45 ~ +85	°C
Storage Temperature	Tstg	-45 ~ +100	°C
Soldering Temperature(*1)	Tsol	250	°C

(*1)、 For 5 Sec

●Electrical And Optical Characteristics(Ta=25°C)

Parameter	Symbol	Test Condition	Min.	Typ.	Max.	Unit
Collector-Emitter Saturation Voltage	V _{CE(sat)}	I _c =0.5mA, E _e =0.5mW/cm ²	—	—	0.5	V
Collector-Emitter Breakdown Voltage	V _{(BR)CEO}	I _c =1mA, E _e =0mW/cm ²	30	—	—	V
Emitter-collector Breakdown Voltage	V _{(BR)ECO}	I _e =100 μA, E _e =0mW/cm ²	5	—	—	V
Light Current	I _{c(on)}	V _{ce} =5V, E _e =0.5mW/cm ²	0.40	0.65	—	mA
Dark Current	I _d	V _{ce} =10V, E _e =0mW/cm ²	—	—	100	nA
Rise Time	Tr	F=100Hz, V _{ce} =5V, R _L =1kΩ	—	10	—	μs
Fall Time	Tf		—	15	—	μs
Viewing Angle	2θ1/2	V _{ce} =5V, E _e =0.5mW/cm ²	—	30	—	deg

BRIGHT LED ELECTRONICS CORP.

●Device Number:BPT-BP0331

Page: 3

●Dimensions

Version:1.0

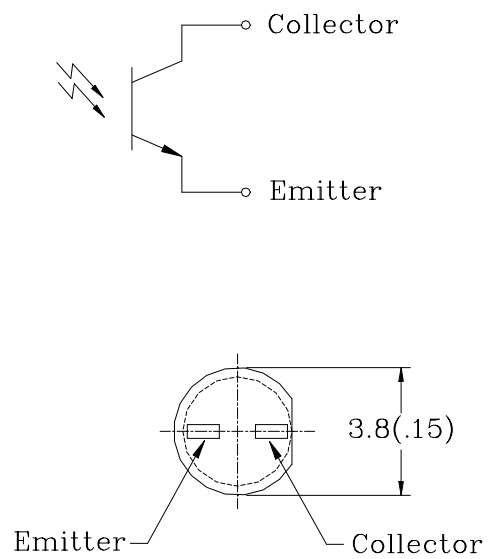
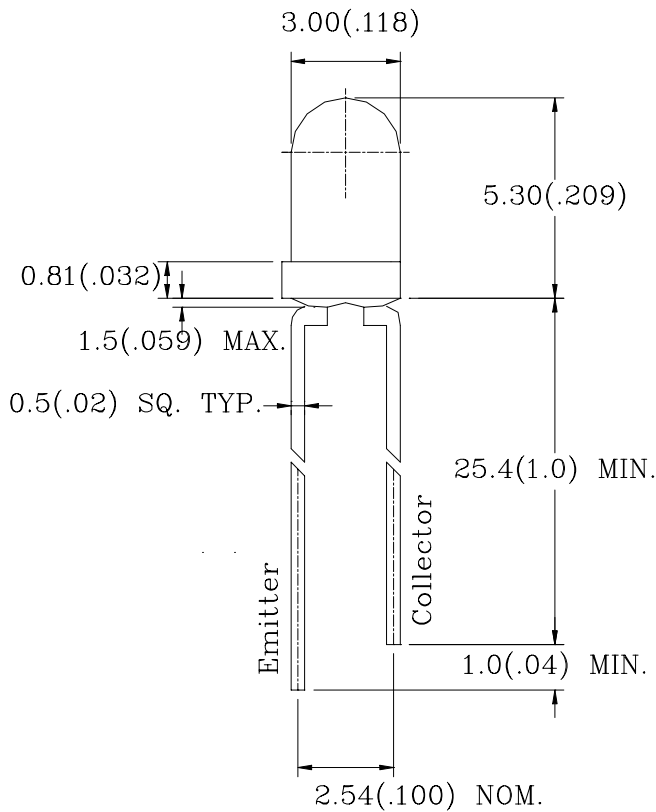

Notes:

- 1、All dimensions are in millimeters (inches).
- 2、Tolerance is $\pm 0.25\text{mm}$ ($0.01''$) unless otherwise specified.
- 3、Lead spacing is measured where the leads emerge from the package.
- 4、Specifications are subject to change without notice.

BRIGHT LED ELECTRONICS CORP.

●Device Number:BPT-BP0331

Page: 4

●Electrical And Optical Curves(Ta=25°C)

Version:1.1

FIG.1 Dark Current Vs. Ambient Temperature

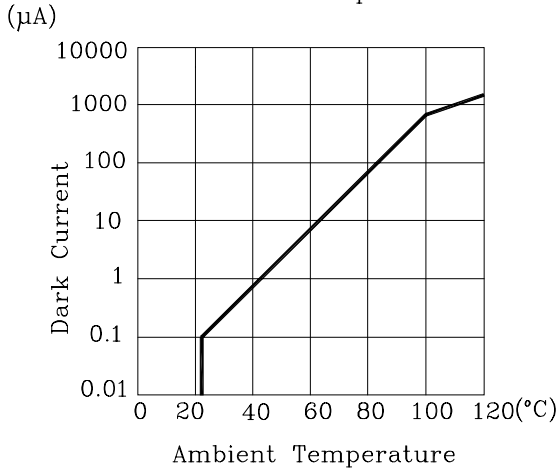

FIG.2 Power Dissipation Vs. Ambient Temperature

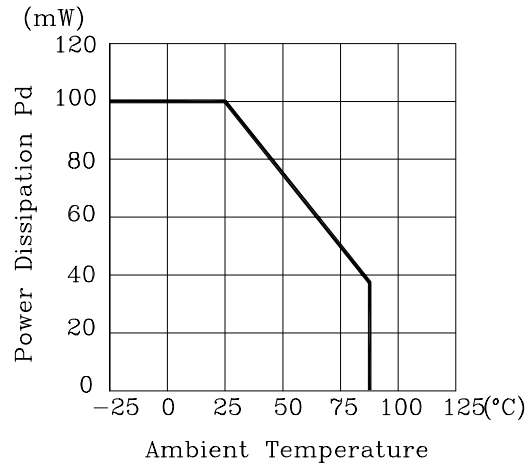

FIG.3 Rise And Fall Time Vs. Load Resistance

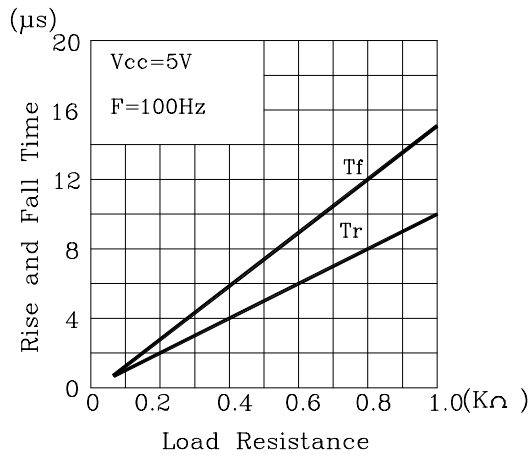

FIG.4 Relative Collector Current Vs. Irradiance

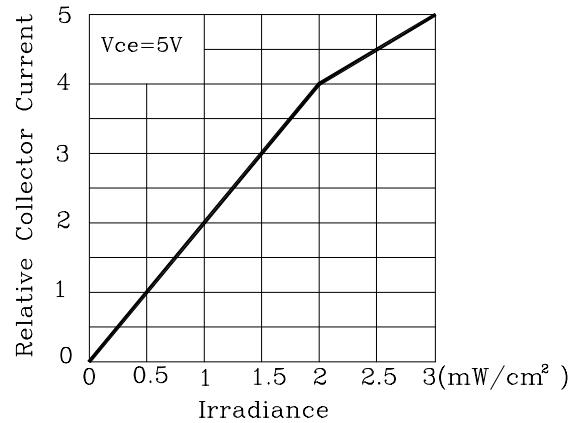

FIG.5 Radiation Diagram

