

## END-LOOK PACKAGE LIGHT EMITTING DIODE

### ● Features:

1. High radiant power and high radiant intensity.
2. Standard T-1 package.
3. Peak wavelength  $\lambda_p=880\text{nm}$ .
4. Good spectral matching to Si- photo detector.
5. Radiant angle:  $30^\circ$
6. Lens Appearance: Water Clear.
7. This product doesn't contain restriction substance, comply ROHS standard

### ● Applications:

1. Remote Control.
2. Automatic Control System.

### ● Package Dimensions:

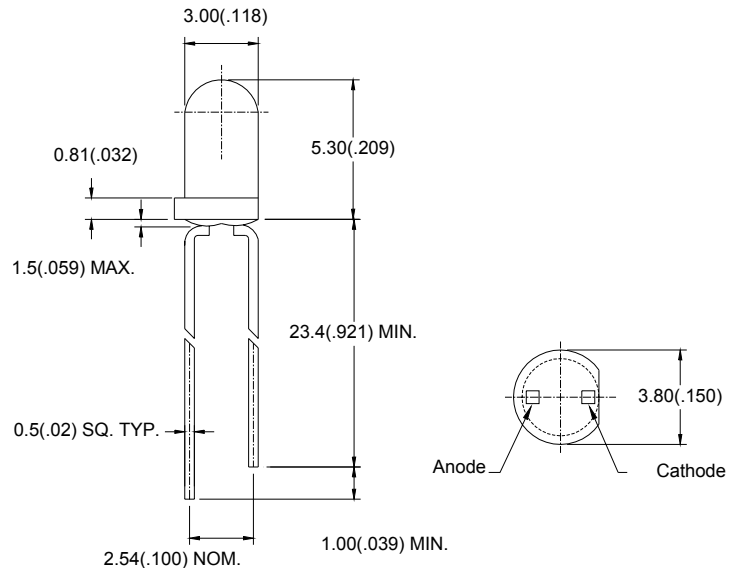

### NOTES:

1. All dimensions are in millimeters (inches).
2. Tolerance is  $\pm 0.25\text{mm}$  ( $0.01''$ ) unless otherwise specified.
3. Lead spacing is measured where the leads emerge from the package.
4. Specifications are subject to change without notice.

### ● Absolute Maximum Ratings( $T_a=25^\circ\text{C}$ )

Parameter	Symbol	Rating	Unit
Power Dissipation	$P_d$	100	mW
Continuous Forward Current	$I_F$	100	mA
Peak Forward Current <sup>*1</sup>	$I_{FP}$	1.0	A
Reverse Voltage	$V_R$	5	V
Operating Temperature	$T_{opr}$	$-45^\circ\text{C} \sim 85^\circ\text{C}$	-
Storage Temperature	$T_{stg}$	$-45^\circ\text{C} \sim 100^\circ\text{C}$	-
Soldering Temperature	$T_{sol}$	$260^\circ\text{C}$ (for 5 seconds)	-

<sup>\*1</sup> Condition for is  $I_{FP}$  pulse of 1/10 duty and 0.1 msec width.

● **Optical- Electrical Characteristics (@ $T_A=25^{\circ}C$ )**

Parameter	Symbol	Test Conditions	Min	TYP	Max	Unit
Radiant Intensity	$I_e$	$I_F=50mA$	11.78	33.4	-	mW/sr
Forward Voltage	$V_F$	$I_F=50mA$	-	1.3	1.7	V
Reverse Current	$I_R$	$V_R=5V$	-	-	100	$\mu A$
Peak Wavelength	$\lambda_p$	$I_F=20mA$	-	880	-	nm
Spectral Line Half- Width	$\Delta \lambda$	$I_F=20mA$	-	50	-	nm
Viewing Angle	$2\theta_{1/2}$	$I_F=20mA$	-	30	-	deg

● **Typical Optical-Electrical Characteristic Curves**

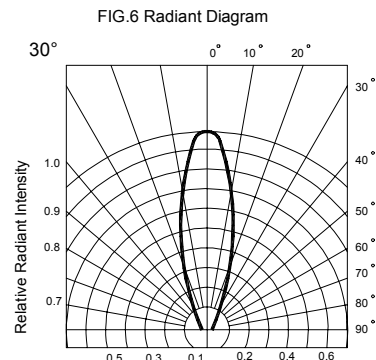
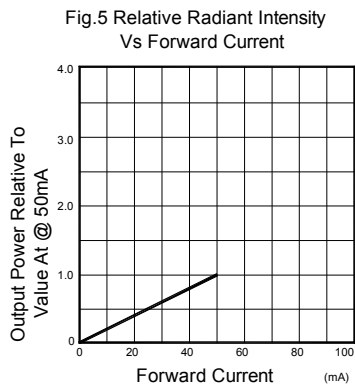
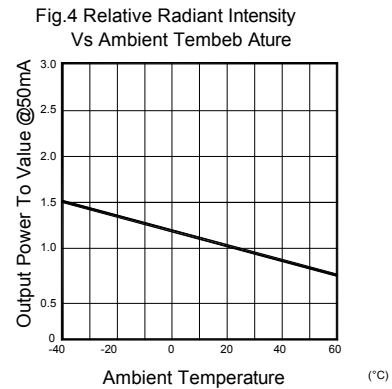
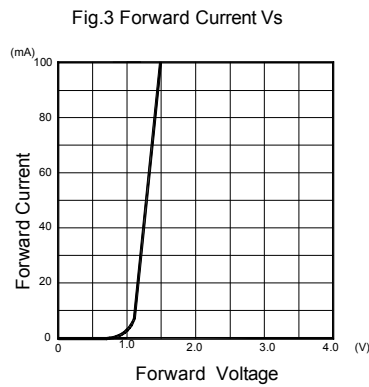
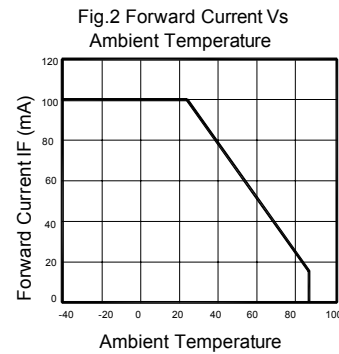
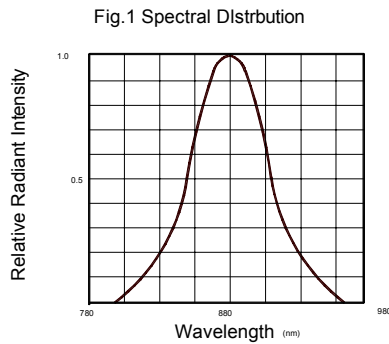

● Tapping and packaging specifications(Units: mm)

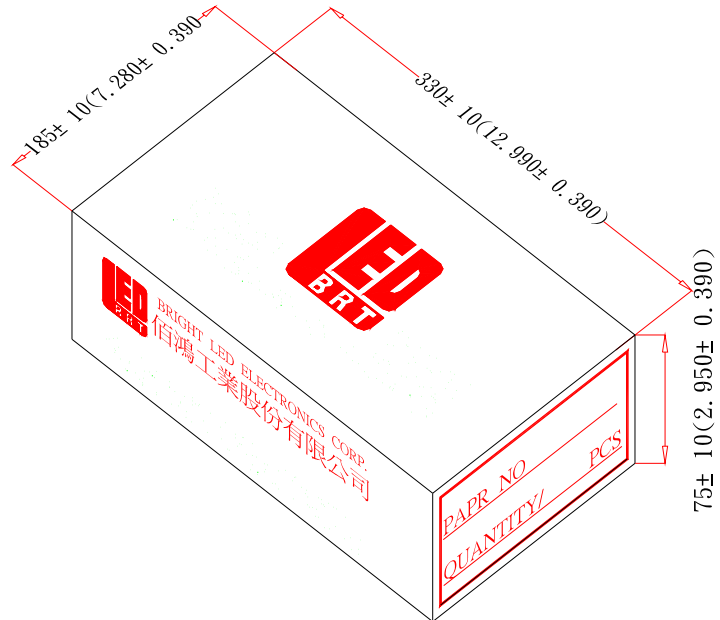

● Packaging Bag Dimensions

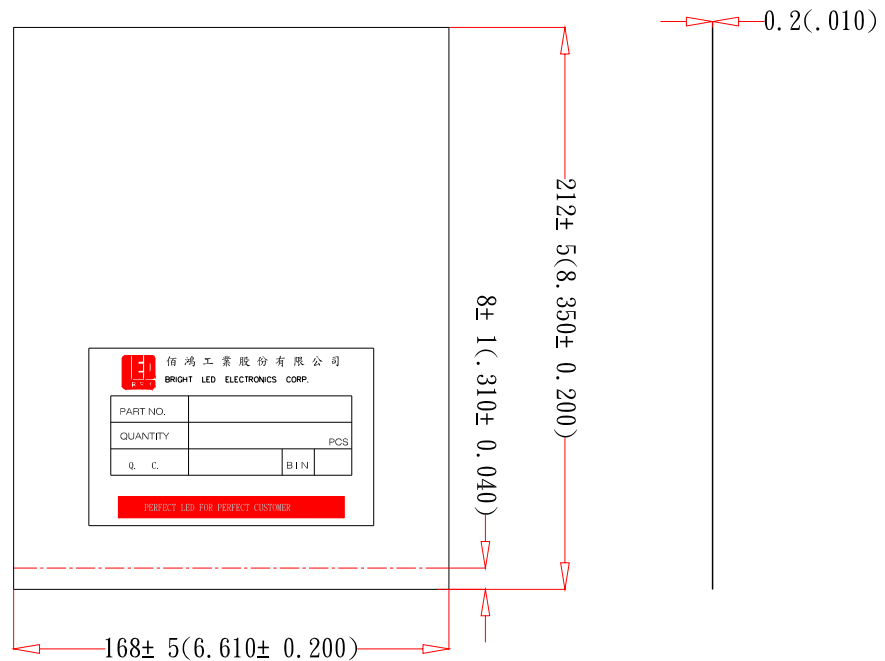

**Notes:**

- 1、1000pcs per bag, 8Kpcs per box.
- 2、All dimensions are in millimeters(inches).
- 3、Specifications are subject to change without notice.