

END-LOOK PACKAGE INFRARED EMITTING DIODE

● Features:

1. High radiant power and high radiant intensity.
2. Standard T-1 3/4(5mm)package.
3. Peak wavelength $\lambda_p=940\text{nm}$.
4. Good spectral matching to Si- photo detector.
5. Radiant angle: 30°
6. Lens Appearance: Water Clear.
7. This product doesn't contain restriction substance, comply RoHS standard

● Applications:

1. Remote Control.
2. Automatic Control System.

● Package Dimensions:

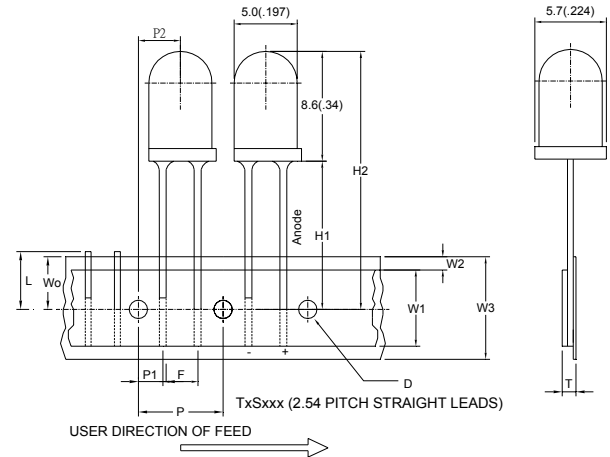

H1	-----25.5(1.00)±0.5
L	-----11.0(.433) Max.
Wo	-----9.0(.35)
P1	-----5.0(.196)
F	-----2.54(0.1)
P	-----12.7(.50)
D	-----? 4.0(.157)
W1	-----15.0(.590)
W2	-----4.0(.157) Max.
W3	-----18.25(.718)
T	-----1.42(.055) Max.

NOTES:

1. All dimensions are in millimeters (inches).
2. Tolerance is $\pm 0.25\text{mm}$ (0.01") unless otherwise specified.
3. Lead spacing is measured where the leads emerge from the package.
4. Specifications are subject to change without notice.

● Absolute Maximum Ratings(Ta=25°C)

Parameter	Symbol	Rating	Unit
Power Dissipation	Pd	100	mW
Continuous Forward Current	I _F	100	mA
Peak Forward Current ^{*1}	I _{FP}	1.0	A
Reverse Voltage	V _R	5	V
Operating Temperature	Topr	-45°C~85°C	-
Storage Temperature	Tstg	-45°C~100°C	-
Soldering Temperature	Tsol	260°C (for 5 seconds)	-

^{*1} Condition for is I_{FP} pulse of 1/10 duty and 0.1 msec width.

● **Optical- Electrical Characteristics (@T_A=25°C)**

Parameter	Symbol	Test Conditions	Min	TYP	Max	Unit
Radiant Intensity	I _e	I _F =50mA	16.5	33	-	mW/sr
Forward Voltage	V _F	I _F =50mA	-	1.25	1.5	V
Reverse Current	I _R	V _R =5V	-	-	100	μA
Peak Wavelength	λ _p	I _F =50mA	-	940	-	nm
Spectral Line Half- Width	Δλ	I _F =50mA	-	50	-	nm
Viewing Angle	2θ _{1/2}	I _F =50mA	-	30	-	deg

● **Typical Optical-Electrical Characteristic Curves**

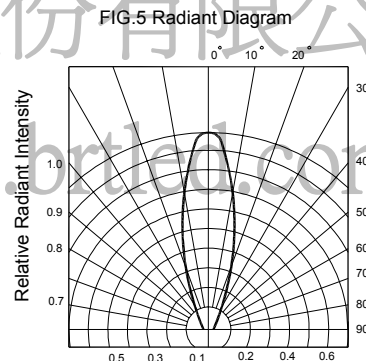
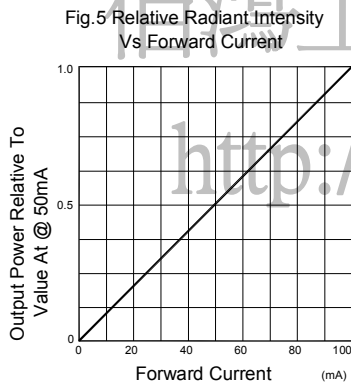
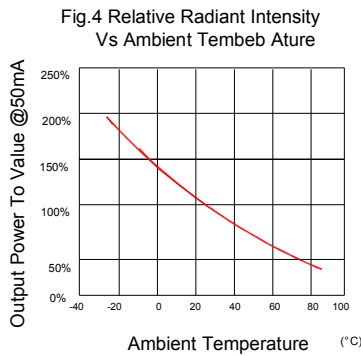
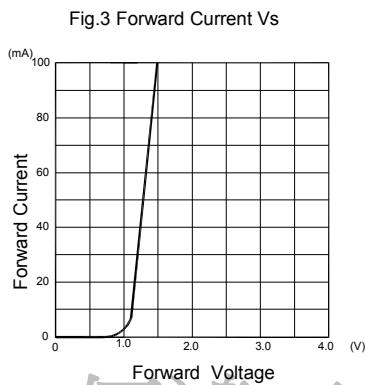
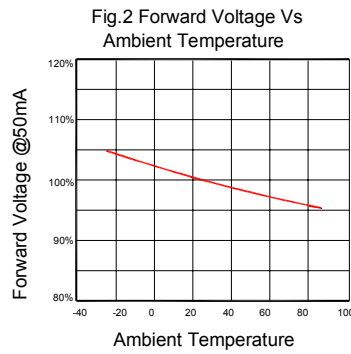
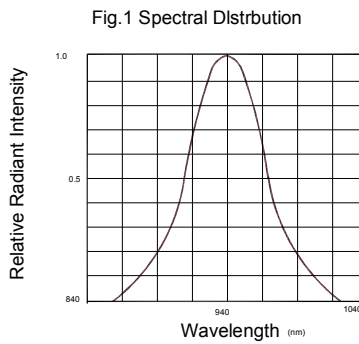

● Tapping and packaging specifications(Units: mm)

ITEM	SYMBOL	SPECIFICATION			
		Minimum		Maximum	
		mm	inch	mm	inch
Reel Diameter	D	78.20	3.079	380.00	14.96
Core Diameter	D1	34.90	1.374	102.00	4.02
Hub Recess Inside Diameter	D2	28.60	1.126	88.00	3.47
Arbor Hole Diameter	D3	13.8	0.543	38.10	1.50
Overall Reel Thickness	T	-	-	57.20	2.25
Inside Reel Flange Thick	T1	30.00	1.181	50.00	1.97

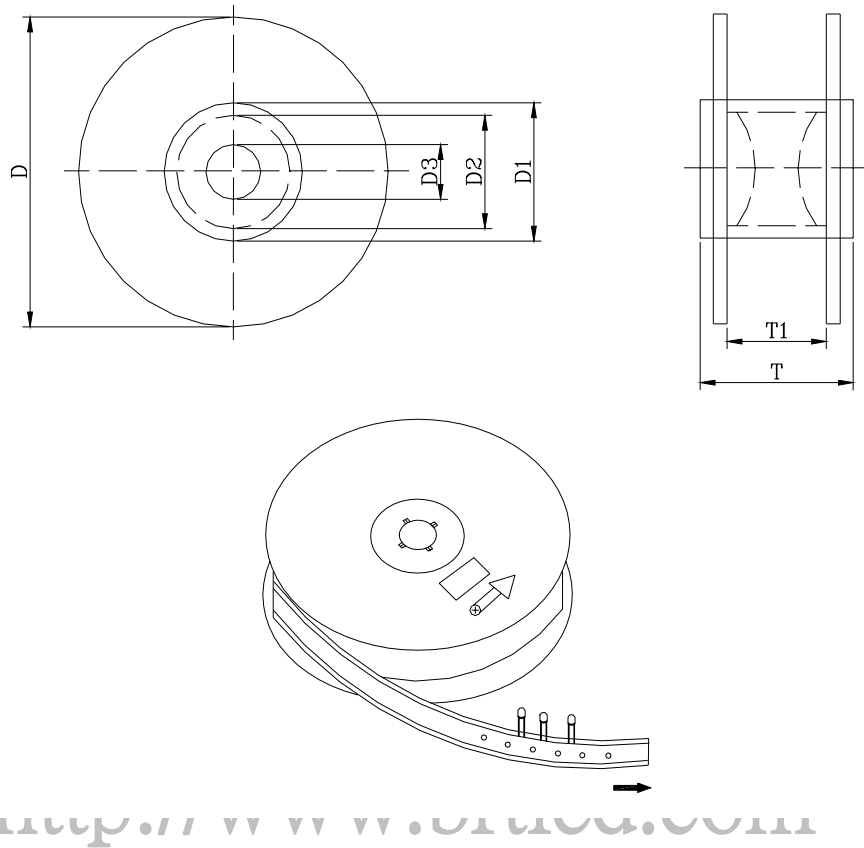



Infrared Emitting Diode Specification

- Commodity: Infrared emitting diode
- Intensity Bin Limits (At 50mA)

BIN CODE	Min.(mW/sr)	Max.(mW/sr)
13	16.50	31.28
14	23.12	43.79
15	32.36	61.30
16	45.31	85.82

佰鴻工業股份有限公司

<http://www.brtled.com>