

● Absolute maximum ratings

Parameter	Symbol	Rating	Unit
DC Input Forward Current *	I_{IN}	160	mA
Power Dissipation	P_D	5	W
Reverse input voltage	V_r	36	V DC
ESD	HBM	2000	V
Storage Temperature	T_{stg}	-40~80	°C
Temperature of Al MCPCB	T_b	70	°C

* Proper current derating must be followed to keep the temperature of Al MCPCB(T_b) below 70°C.

● Electrical & Optical Characteristics ($T_b=25^\circ\text{C}$)

Parameter	Symbol	Condition	Min.	Typ.	Max.	Unit
Forward Voltage*	V_F	$I_F = 160\text{mA}$	-	-	36	V
Total Flux	Φ_v	$I_F = 160\text{mA}$	-	300	-	lm
Light Efficient	η	$I_F = 160\text{mA}$	-	60	-	lm/W
Color Temperature	CCT	$I_F = 160\text{mA}$	2580	-	2870	K
Color Rendering Index	CRI	$I_F = 160\text{mA}$	-	60	-	
Viewing Angle	$2\theta_{1/2}$	$I_F = 160\text{mA}$	-	120	-	degree
Life Time	t	at $T_p \leq 50^\circ\text{C}$	-	30,000	-	hrs

* A power supply with maximum constant current source of 160mA is highly recommended.

佰鴻工業股份有限公司

<http://www.brtled.com>

● Typical electro-optical characteristics curves

Fig.1 RELATIVE INTENSITY VS. WAVELENGTH

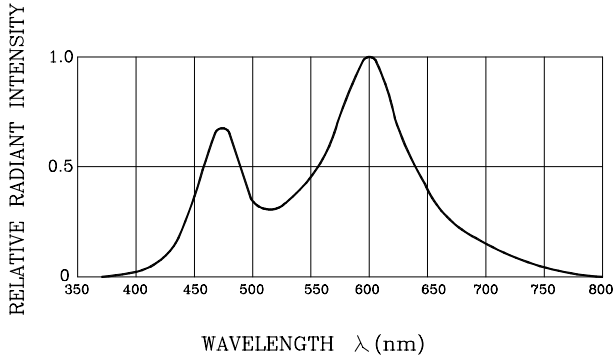

Fig.2 FORWARD CURRENT VS. AMBIENT TEMPERATURE

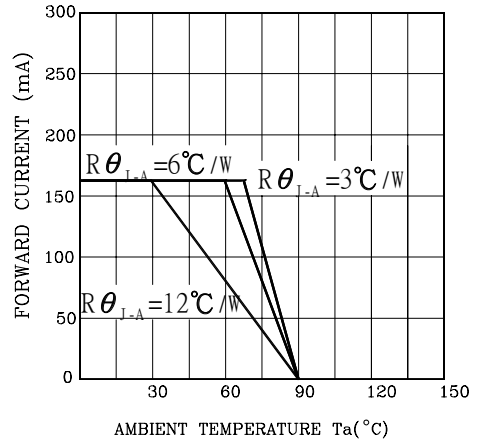

Fig.3 FORWARD CURRENT VS. FORWARD VOLTAGE

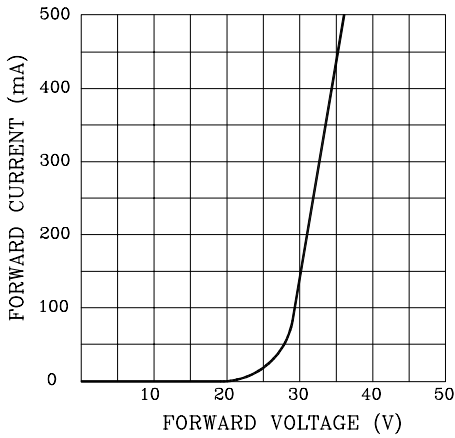

Fig.4 RELATIVE LUMINOUS INTENSITY VS. JUNCTION TEMPERATURE

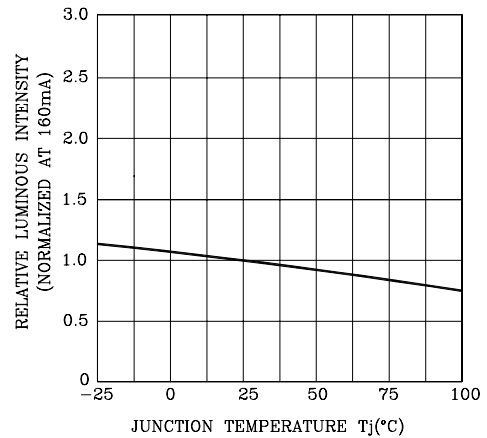

Fig.5 RELATIVE LUMINOUS INTENSITY VS. FORWARD CURRENT

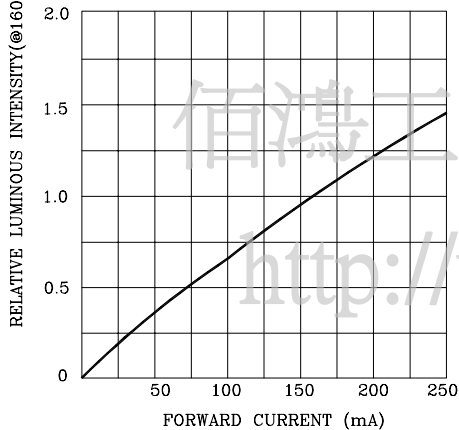
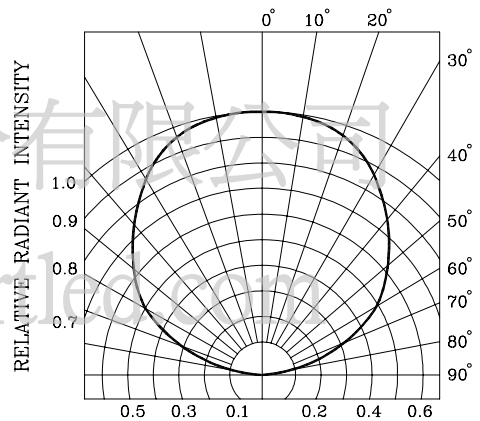
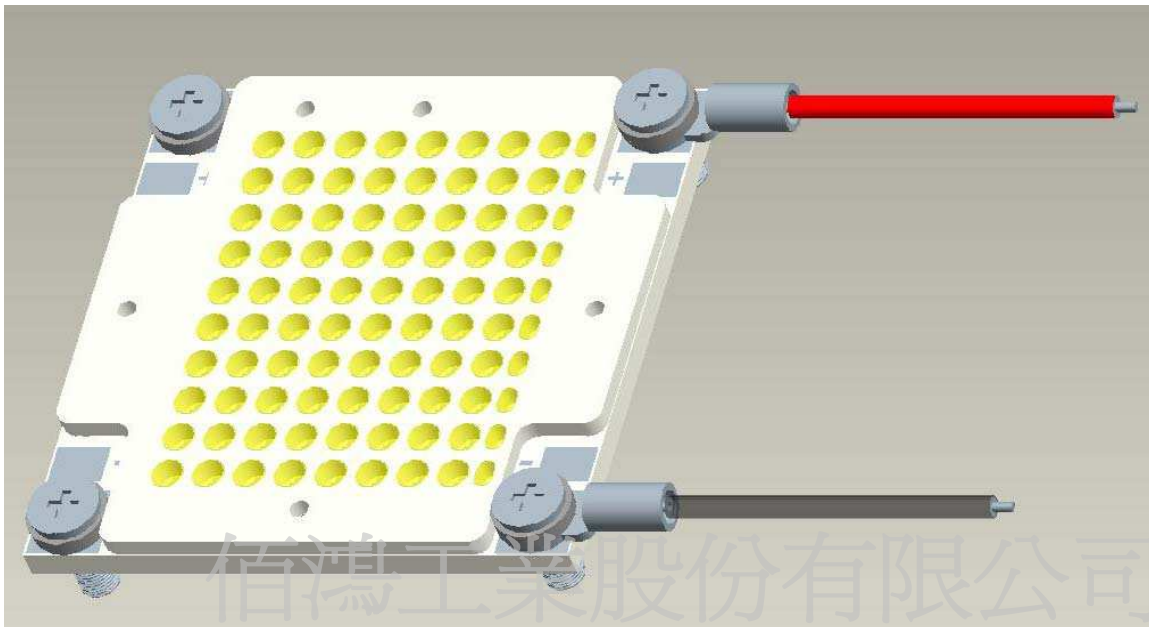
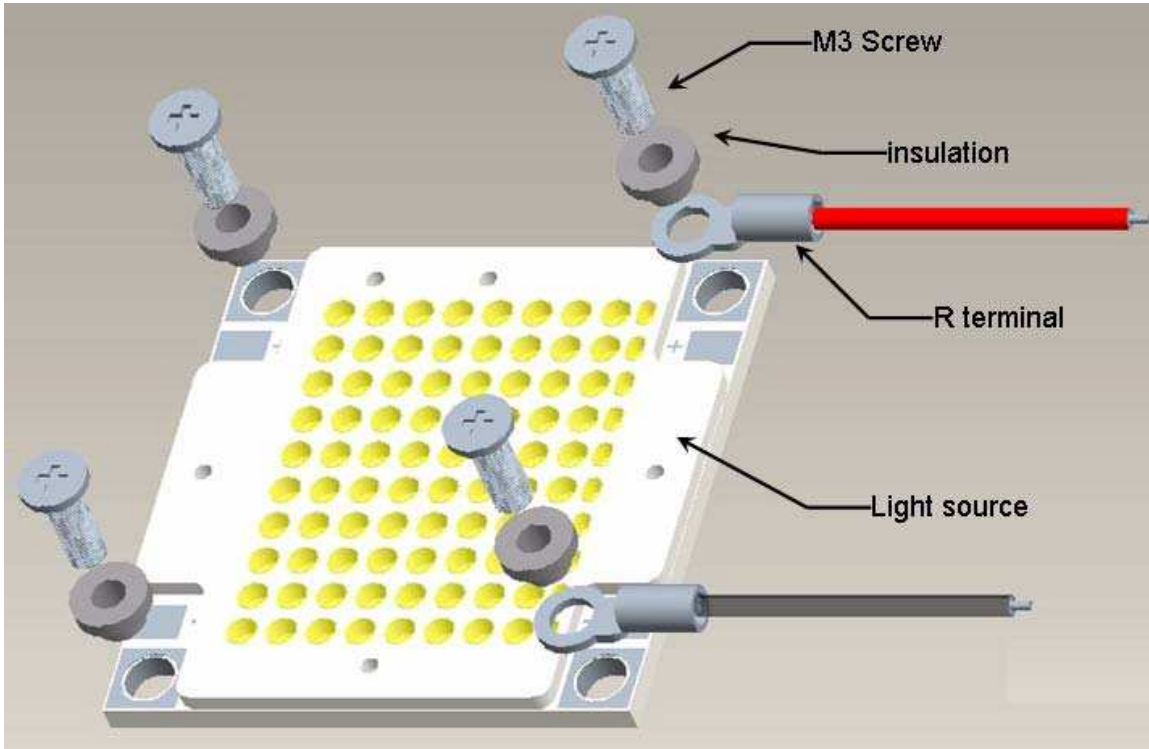

Fig.6 RADIATION DIAGRAM



● Components Assembling Demonstration



<http://www.brtled.com>

● Components Assembling Demonstration :

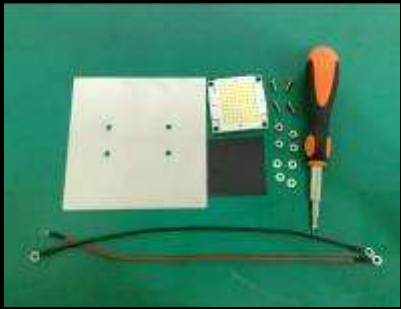
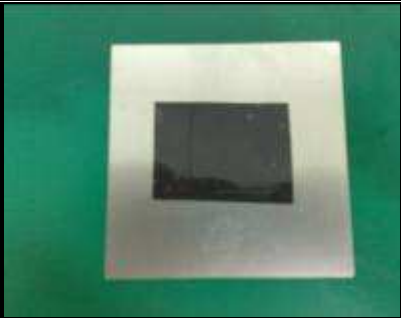
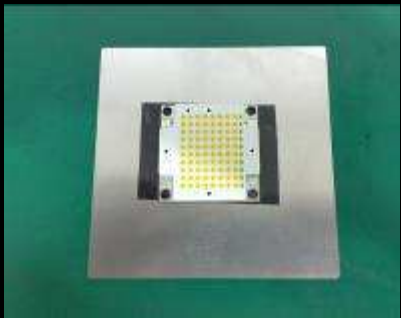
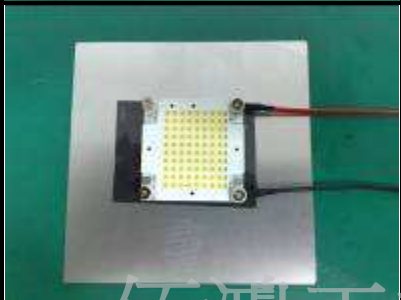
Steps	Pictures	Instructions	Remarks
1		<p>Items to prepare: light source, heat dispersion tape, heat dispersion plate, screwdriver, screws, nuts, washers, and R terminal wires</p>	<p>Screws, nuts, and washers may be required to firmly attach the heat dispersion module in its fixed position.</p>
2		<p>Attach the heat dispersion tape on the heat dispersion plate at its fixed and locked position.</p>	<p>Heat dispersing paste may be applied to the back of the light source.</p>
3		<p>Attach the light source to the heat dispersion plate.</p>	
4		<ol style="list-style-type: none"> 1. Connect all R terminal wires to the heat dispersion plate. 2. Evenly tighten all screws. 	<p>Failure is possible if force is applied to improperly positioned screws.</p>

佰鴻工業股份有限公司

Notes:

1. A Components bag is included : R Terminal with 20cm red wire×1、R Terminal with 20cm black wire×1、Insulating WashersX4、M3 ScrewsX4.

<http://www.brtled.com>

● Packing(unit: mm[in]):

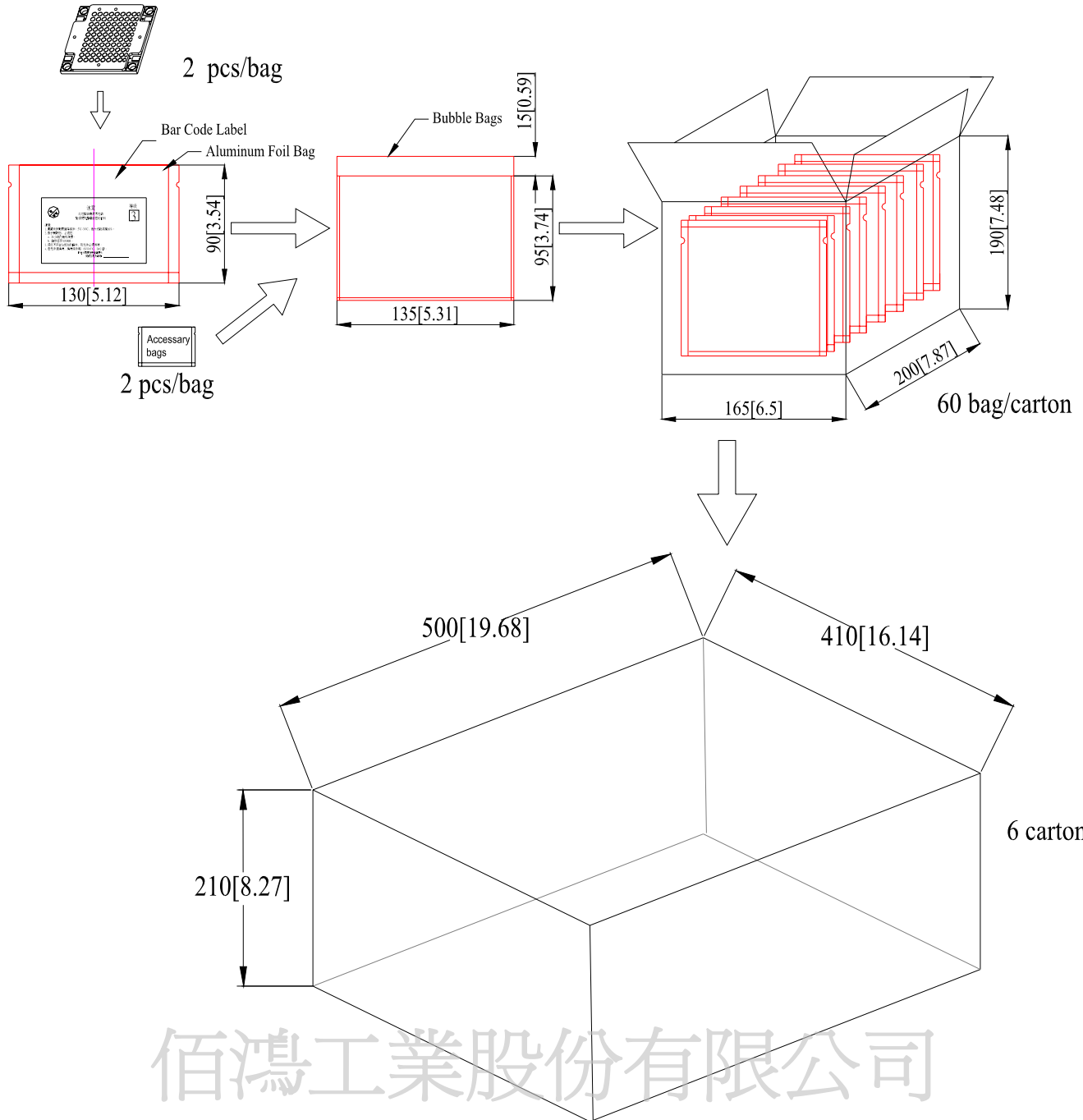

佰鴻工業股份有限公司

<http://www.brtled.com>

Notes:

1. Dimension : mm[in].
2. Tolerance : ±10[0.40]mm[in].

● Total Flux Bin Limits (at $I_F = 160\text{mA}$)

BIN CODE	Min. (lm)	Max. (lm)
T	205	266
U	266	346
V	346	449

Tolerance for each Bin limit is $\pm 15\%$

● Color Temperature Bin Limits (at $I_F = 160\text{mA}$) ; as specified in ANSI C78.377-2008.

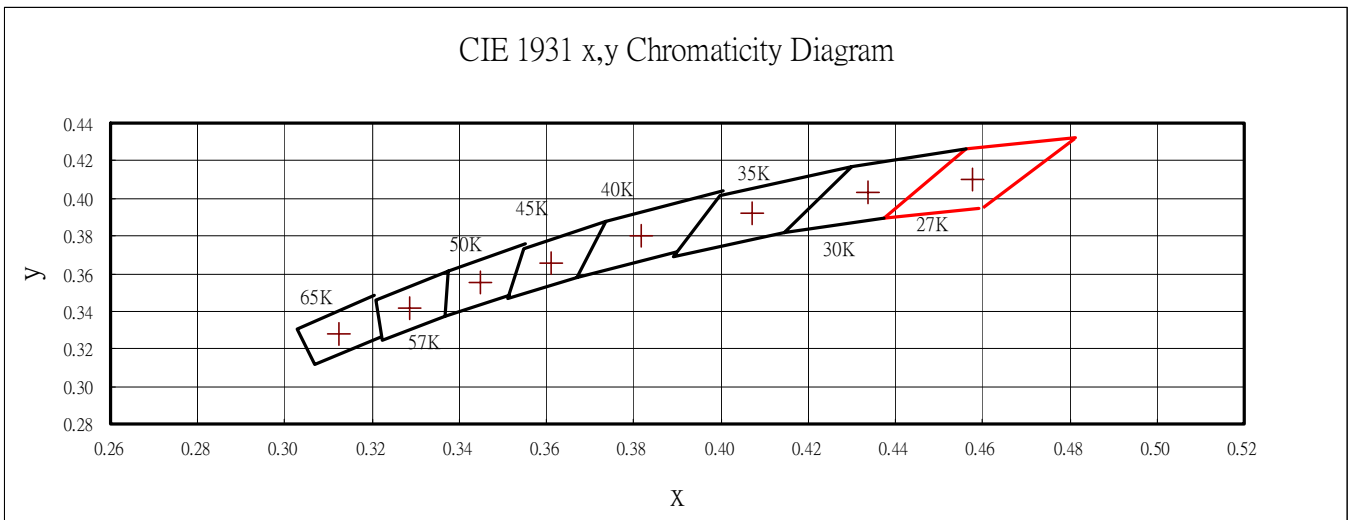

BIN CODE	Nominal CCT	CCT Range	Chromaticity Coordinates				
			x	y	x	y	
K27	2700K	2580-2870	x	0.4813	0.4562	0.4373	0.4593
			y	0.4319	0.4260	0.3893	0.3944

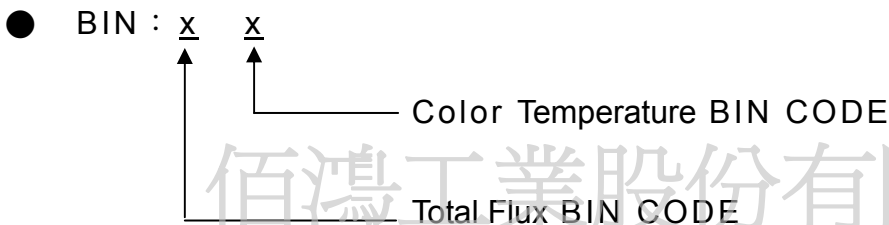

Notes:

- Bin categories are established for classification of products. Products may not be available in all bin categories.