

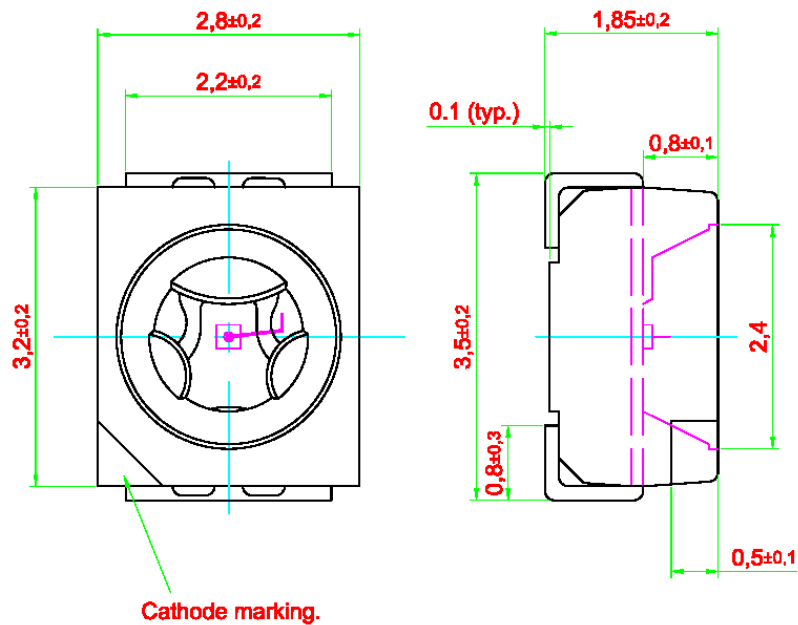

● **Feature:**

1. High brightness surface mount LED.
2. Based on GaN technology.
3. 120° viewing angle.
4. Small package outline (LxWxH) of 2.8 x 3.2 x 1.8 mm.
5. Qualified according to JEDEC moisture sensitivity Level 2.
6. Compatible to both IR reflow soldering and TTW soldering.

● **Package Dimension:**



Solder Pad Design

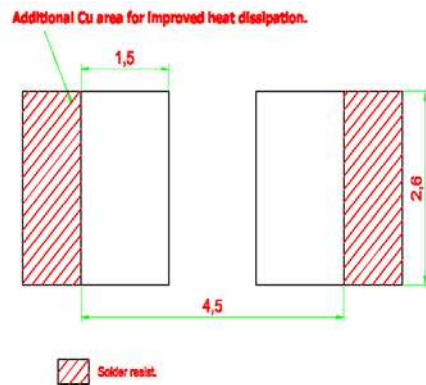



● **Optical Characteristics:**

Part Number	Chip Technology / Color	Viewing Angle	Luminous Intensity @ If = 20mA Iv (mcd)
BL-PDB-JJS-C10 <ul style="list-style-type: none">• BIN K1• BIN K2• BIN L1• BIN L2	GaN / Blue, 466 nm	120	7.2 ... 18.0 7.2 ... 9.0 9.0 ... 11.2 11.2 ... 14.0 14.0 ... 18.0
BL-PDW-JJD-C10 <ul style="list-style-type: none">• BIN N1• BIN N2• BIN P1• BIN P2	GaN / White	120	28.5 ... 71.5 28.5 ... 35.5 35.5 ... 45.0 45.0 ... 56.0 56.0 ... 71.5

NOTE:

1. Other luminous intensity groups are also available upon request.
2. Luminous intensity is measured with an accuracy of $\pm 11\%$.
3. Wavelength binning is carried for all units as per the wavelength-binning table. Only one wavelength group is allowed for each reel.
4. An optional Vf binning is also available upon request. Binning scheme is as per following table.

● **Absolute Maximum Ratings:**

Parameter	Maximum Value	Unit
DC forward current.	20	mA
Peak pulse current; ($t_p \leq 10 \mu s$, Duty cycle = 0.005)	200	mA
Forward voltage (IF=20mA)	4.55	V
Reverse voltage (IR=10 μA)	5	V
LED junction temperature.	125	$^{\circ}C$
Operating temperature.	-40 ... +100	$^{\circ}C$
Storage temperature.	-40 ... +100	$^{\circ}C$
Power dissipation (at room temperature)	85	mW



● **Vf Binning:**

Vf Bin @ 20mA	Forward voltage (V)
Standard	3.65 ... 4.55
02	3.65 ... 3.95
03	3.95 ... 4.25
04	4.25 ... 4.55

Forward voltage, Vf is measured with an accuracy of ± 0.1 V.

● **BL-PDW, White Color Grouping**

GaN White Bin Structure

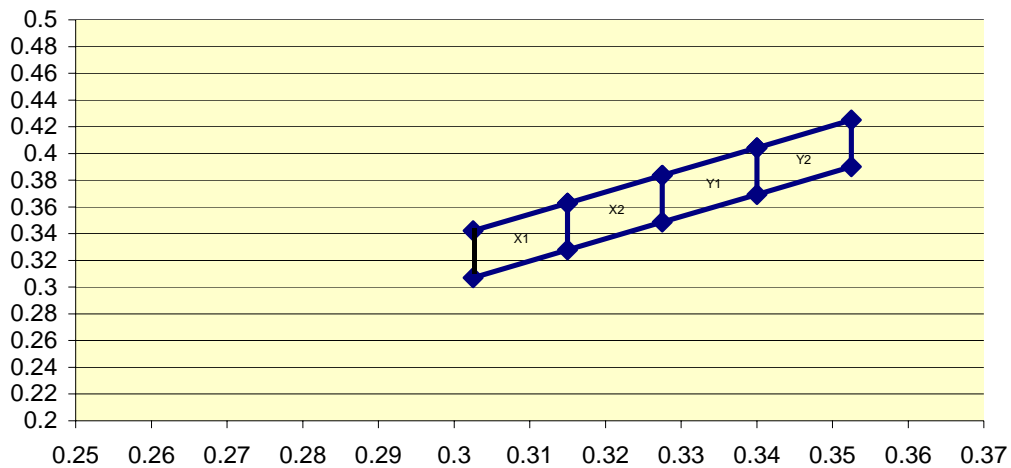

Bin		1	2	3	4
X1	Cx	0.303	0.315	0.315	0.303
	Cy	0.307	0.328	0.363	0.342
X2	Cx	0.315	0.328	0.328	0.315
	Cy	0.328	0.349	0.384	0.363
Y1	Cx	0.328	0.34	0.34	0.328
	Cy	0.349	0.369	0.404	0.384
Y2	Cx	0.340	0.353	0.353	0.340
	Cy	0.369	0.39	0.425	0.404

Color coordinate is measured with an accuracy of ± 0.01



● **Typical electro-optical characteristics curves:**

Fig. 1 Relative luminous intensity vs. forward current.

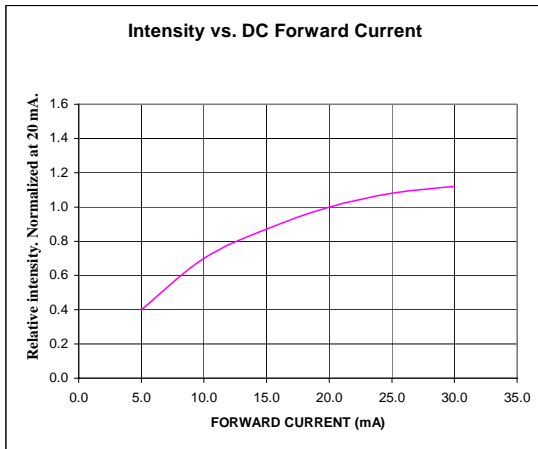

Fig. 2 Forward current vs. forward voltage.

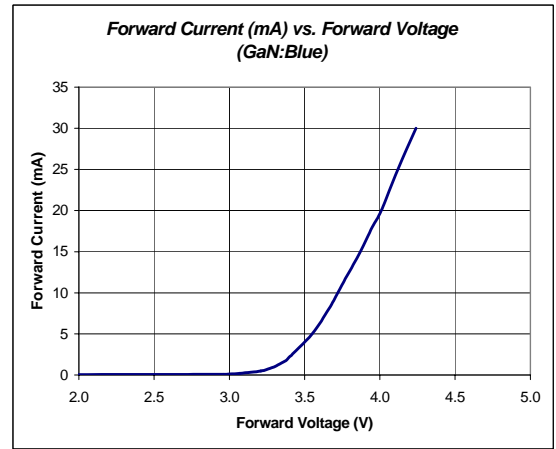

Fig. 3 Radiation pattern.

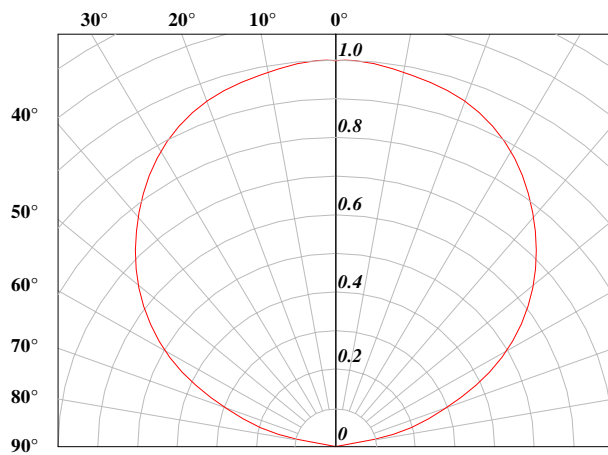

Fig. 4 Maximum forward current vs. temperature.

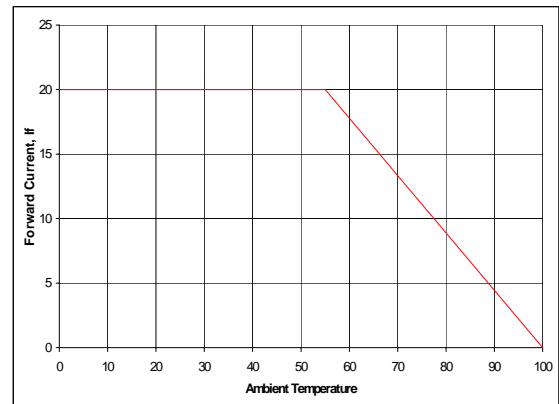

Fig. 5 Relative Intensity vs. Wavelength

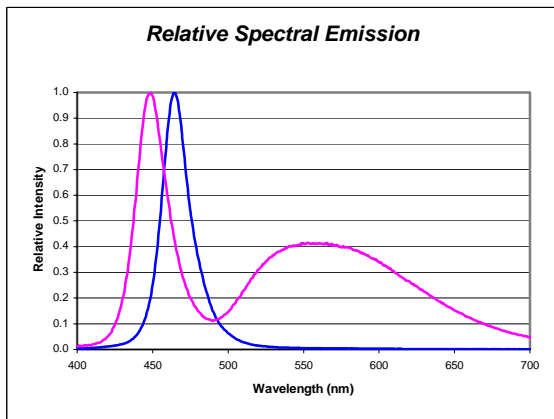



Fig. 6 Recommended IR-reflow Soldering Profile.

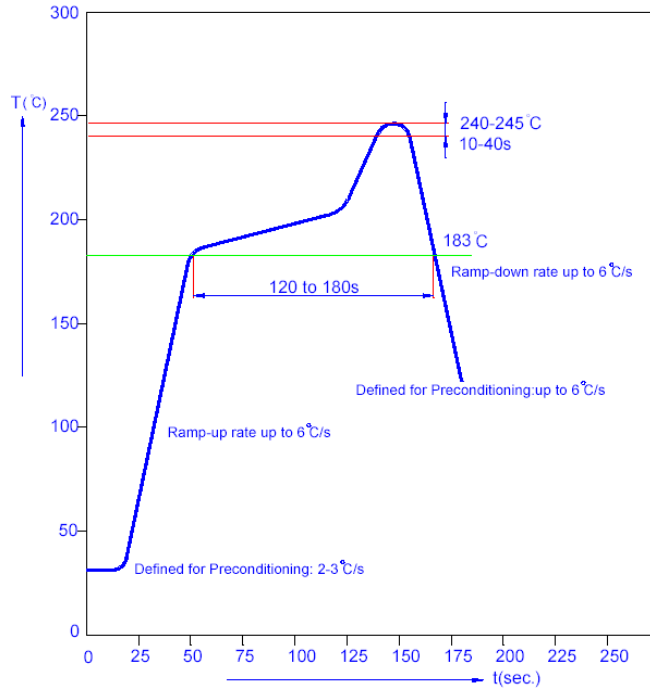

Fig. 7 Recommended TTW Soldering Profile.

