

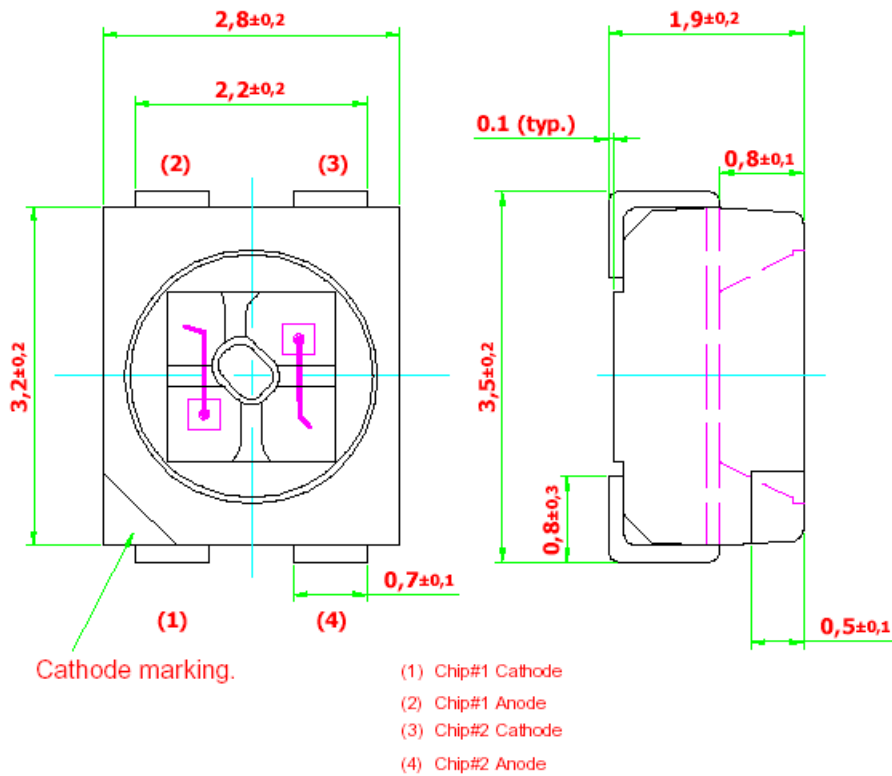

● **Feature:**

1. High brightness bi-color surface mount LED.
2. 120° viewing angle.
3. Small package outline (LxWxH) of 2.8 x 3.2 x 1.9 mm.
4. Qualified according to JEDEC moisture sensitivity Level 2.
5. Compatible to both IR reflow soldering and TTW soldering.
6. RoHS Compliance.

● **Package Dimension:**



Recommended Solder Pad

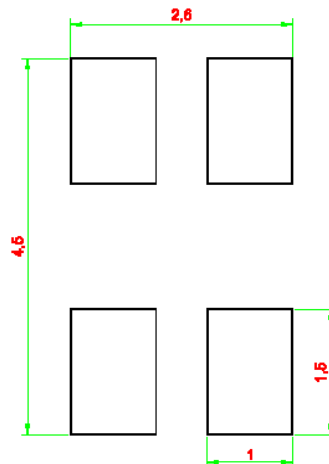



● Optical Characteristics:

Part Number	Color λ_{dom} (nm)		Luminous Intensity @ $I_f = 20mA$. I_v (mcd)	
	Chip#1	Chip#2	Chip#1	Chip#2
BL-PMRG-GJS • BIN L L • BIN L M • BIN M L • BIN M M	Red	Green	11.2 ... 28.5	11.2 ... 28.5
	625	570	11.2 ... 18.0	11.2 ... 18.0
			11.2 ... 18.0	18.0 ... 28.5
			18.0 ... 28.5	11.2 ... 18.0
			18.0 ... 28.5	18.0 ... 28.5
BL-PMRY-GJS • BIN L L • BIN L M • BIN M L • BIN M M	Red	Yellow	11.2 ... 28.5	11.2 ... 28.5
	625	587	11.2 ... 18.0	11.2 ... 18.0
			11.2 ... 18.0	18.0 ... 28.5
			18.0 ... 28.5	11.2 ... 18.0
			18.0 ... 28.5	18.0 ... 28.5
BL-PMYG-GJS • BIN L L • BIN L M • BIN M L • BIN M M	Yellow	Green	11.2 ... 28.5	11.2 ... 28.5
	587	570	11.2 ... 18.0	11.2 ... 18.0
			11.2 ... 18.0	11.2 ... 18.0
			18.0 ... 28.5	18.0 ... 28.5
			18.0 ... 28.5	18.0 ... 28.5

Color	V_f at $I_f=20mA$		Viewing Angle
	Typ.	Max	
Red / Green / Yellow	2.2	2.5	120

NOTE:

1. Luminous intensity is measured with an accuracy of $\pm 11\%$.
2. Half group binning for luminous intensity is also available upon request.



● **Absolute Maximum Ratings:**

Parameter	Maximum Value	Unit
DC forward current.	30	mA
Peak pulse current. ($t_p \leq 10 \mu s$, Duty cycle = 0.005)	1000	mA
Reverse voltage.	5	V
LED junction temperature.	125	°C
Operating temperature.	-40 ... +100	°C
Storage temperature.	-40 ... +100	°C

● **Wavelength Grouping:**

Color	Group	Wavelength distribution (nm)
Red	Full	620 – 635
Yellow	Full	582 – 594
	W	582 – 585
	X	585 – 588
	Y	588 - 591
	Z	591 - 594
Green	Full	564.5 – 576.5
	W	564.5 – 567.5
	X	567.5 – 570.5
	Y	570.5 – 573.5
	Z	573.5 – 576.5



● Typical electro-optical characteristics curves:

Fig.1. Relative luminous intensity vs. forward current.

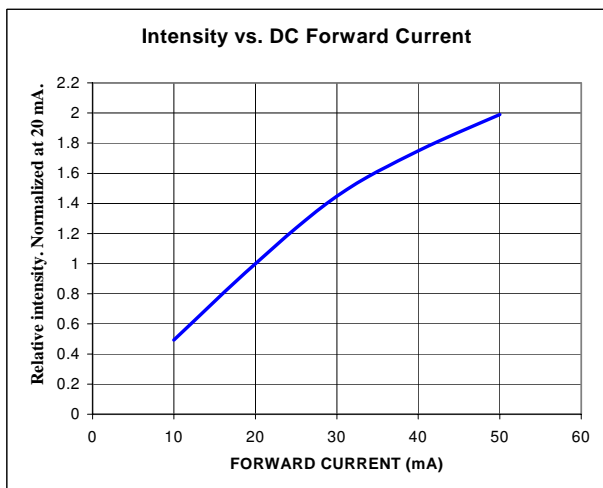

Fig.2 Forward current vs. forward voltage.

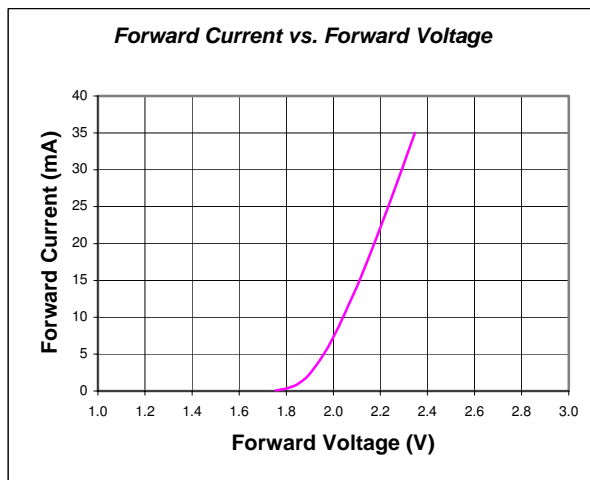

Fig.3 Radiation pattern

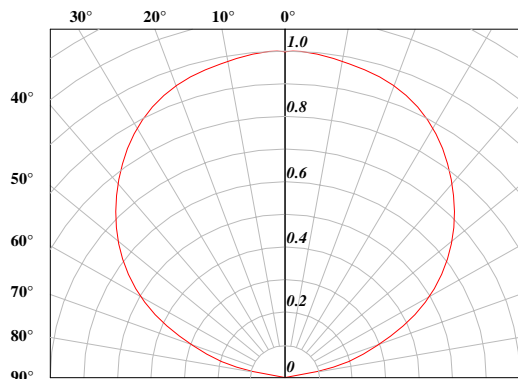

Fig.4 Maximum forward current vs. temperature

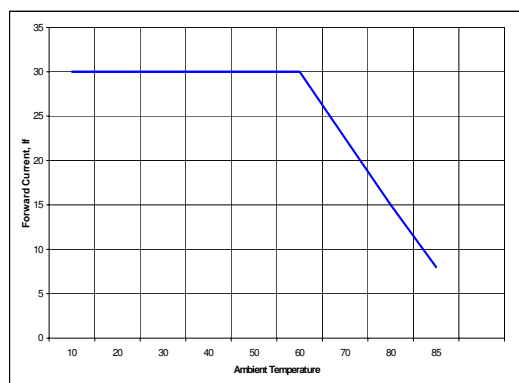

Fig.5 Recommended IR-reflow Soldering Profile.

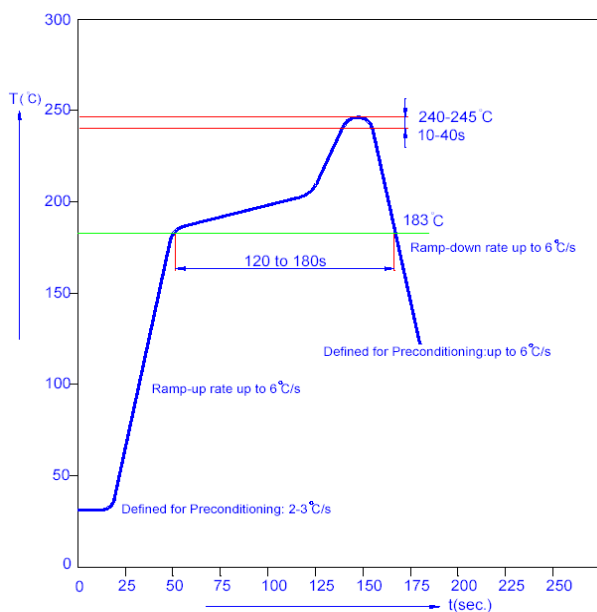
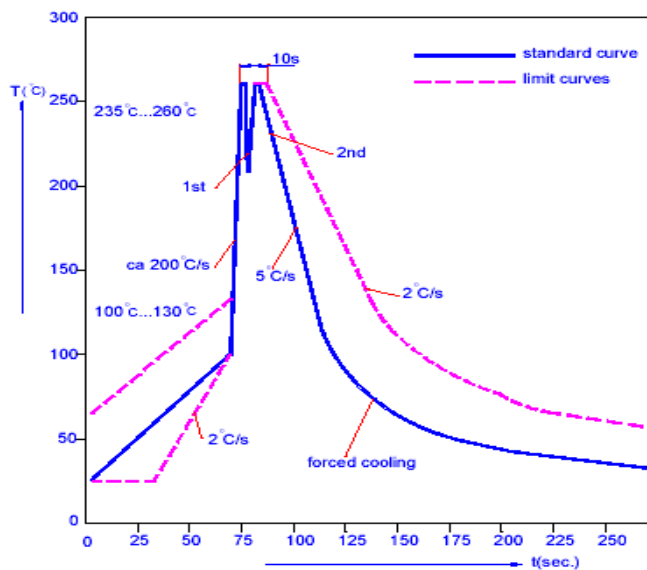

Fig.6 Recommended TTW Soldering Profile





● Taping And Orientation.

Reels come in quantity of 2000 units. Reel diameters 180 mm.

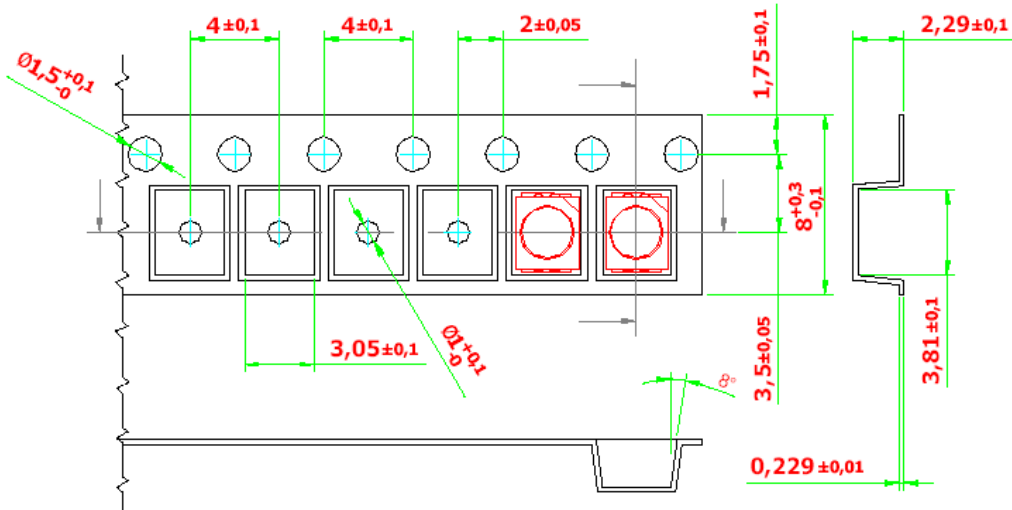

200 mm min. for Ø180 reel.
200 mm min. for Ø330 reel.

480 mm min. for Ø180 reel.
960 mm min. for Ø330 reel.

