

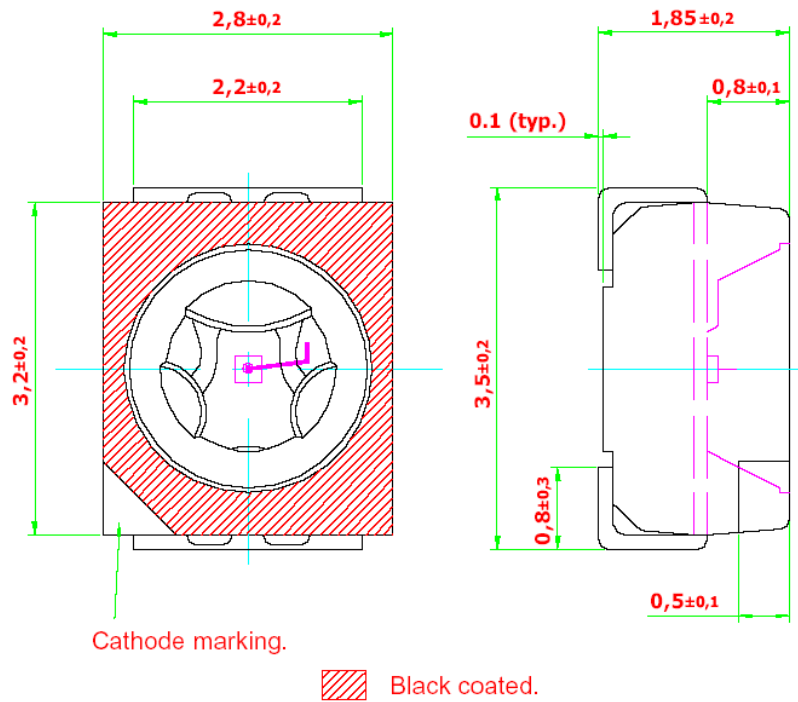

● **Feature:**

1. High brightness surface mount LED.
2. 120° viewing angle.
3. Small package outline (LxWxH) of 3.2 x 2.8 x 1.8 mm.
4. Black coated surface for superior contrast.
5. Qualified according to JEDEC moisture sensitivity Level 2.
6. Compatible to both IR reflow soldering and TTW soldering.

● **Package Dimension:**



Cathode marking.

 Black coated.

Recommended Solder Pad

Additional Cu area for improved heat dissipation.

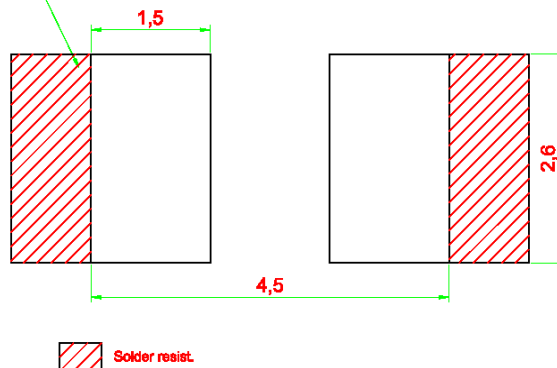

 Solder resist.



● **Optical Characteristics:**

Part Number	Chip Technology / Color	Viewing angle	Luminous Intensity @ If = 20mA Iv ( mcd )
<b>BL-PDB-CJB-C10</b> <ul style="list-style-type: none"> <li>• BIN P1</li> <li>• BIN P2</li> <li>• BIN Q1</li> <li>• BIN Q2</li> </ul>	InGaN / Blue, 470 nm	120	<b>45.0 ... 112.5</b> 45.0 ... 56.0 56.0 ... 71.5 71.5 ... 90.0 90.0 ... 112.5
<b>BL-PDB-SJB-C10</b> <ul style="list-style-type: none"> <li>• BIN Q1</li> <li>• BIN Q2</li> <li>• BIN R1</li> <li>• BIN R2</li> </ul>			<b>71.5 ... 180.0</b> 71.5 ... 90.0 90.0 ... 112.5 112.5 ... 140.0 140.0 ... 180.0
<b>BL-PDR-CJB-C10</b> <ul style="list-style-type: none"> <li>• BIN Q1</li> <li>• BIN Q2</li> <li>• BIN R1</li> <li>• BIN R2</li> </ul>	AllInGaP / Red, 625 nm	120	<b>71.5 ... 180.0</b> 71.5 ... 90.0 90.0 ... 112.5 112.5 ... 140.0 140.0 ... 180.0
<b>BL-PDR-SJB-C10</b> <ul style="list-style-type: none"> <li>• BIN R1</li> <li>• BIN R2</li> <li>• BIN S1</li> <li>• BIN S2</li> </ul>			<b>112.5 ... 285.0</b> 112.5 ... 140.0 140.0 ... 180.0 180.0 ... 224.0 224.0 ... 285.0
<b>BL-PDT-CJB-C10</b> <ul style="list-style-type: none"> <li>• BIN R1</li> <li>• BIN R2</li> <li>• BIN S1</li> <li>• BIN S2</li> </ul>	InGaN / True Green, 525 nm	120	<b>112.5 ... 285.0</b> 112.5 ... 140.0 140.0 ... 180.0 180.0 ... 224.0 224.0 ... 285.0
<b>BL-PDT-SJB-C10</b> <ul style="list-style-type: none"> <li>• BIN S1</li> <li>• BIN S2</li> <li>• BIN T1</li> <li>• BIN T2</li> </ul>			<b>180.0 ... 450.0</b> 180.0 ... 224.0 224.0 ... 285.0 285.0 ... 355.0 355.0 ... 450.0

NOTE:

1. Other luminous intensity groups are also available upon request.
2. Luminous intensity is measured with an accuracy of  $\pm 11\%$ .
3. Wavelength binning is carried for all units as per the wavelength-binning table. Only one wavelength group is allowed for each reel.
4. An optional Vf binning is also available upon request. Binning scheme is as per following table.



● **Absolute Maximum Ratings:**

Parameter	Maximum Value		Unit
	DC forward current.	DDB & DDT 20	
Peak pulse current; (tp ≤ 10 μs, Duty cycle = 0.005)	DDB & DDT 200	DDR 1000	mA
Reverse voltage.	5		V
LED junction temperature.	125		°C
Operating temperature.	-40 ... +100		°C
Storage temperature.	-40 ... +100		°C
Power dissipation ( at room temperature )	DDB & DDT 85	DDR 75	mW

● **Vf Binning:**

Vf Bin @ 20mA	Forward voltage (V) InGaN	Forward Voltage (V) AlInGaP
Standard	3.35 ... 4.25	1.55 ... 2.45
01	3.35 ... 3.65	1.55 ... 1.85
02	3.65 ... 3.95	1.85 ... 2.15
03	3.95 ... 4.25	2.15 ... 2.45

Forward voltage, Vf is measured with an accuracy of ±0.1 V.

● **Wavelength Grouping:**

Color	Group	Wavelength distribution (nm)
BL-PDB; Blue	Full	464 - 476
	W	464 - 468
	X	468 - 472
	Y	472 - 476
BL-PDR; Red	Full	620 – 630
BL-PDT; True Green	Full	520 - 536
	W	520 - 524
	X	524 - 528
	Y	528 - 532
	Z	532 - 536

Wavelength is measured with an accuracy of ±1 nm.



● Typical electro-optical characteristics curves:

Fig. 1 Relative luminous intensity vs. forward current.

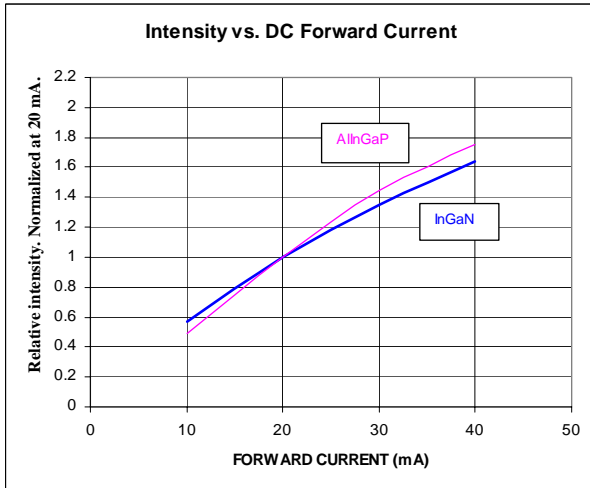

Fig. 2 Forward current vs. forward voltage.

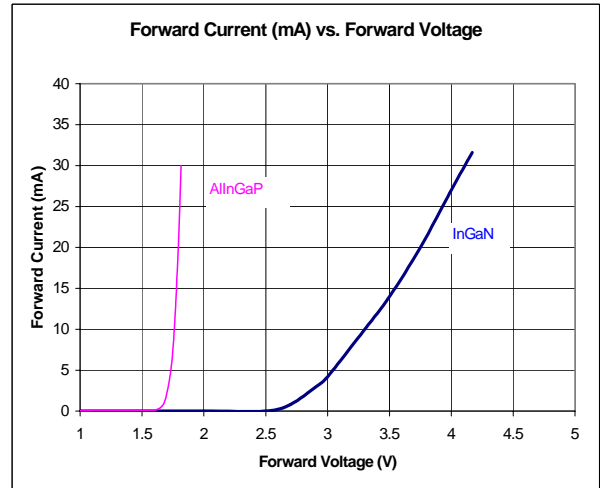

Fig. 3 Radiation pattern.

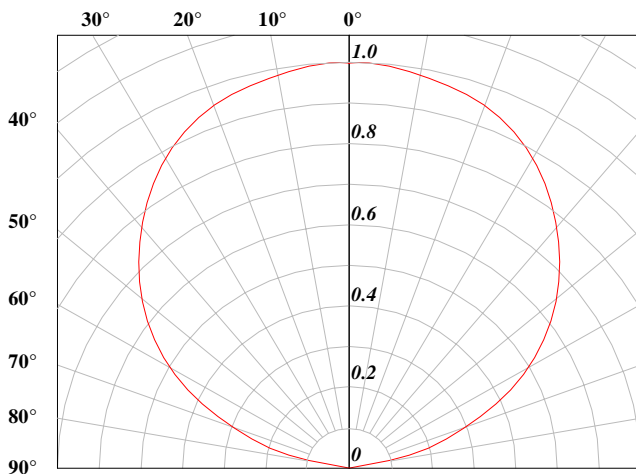

Fig. 4 Maximum forward current vs. temperature.

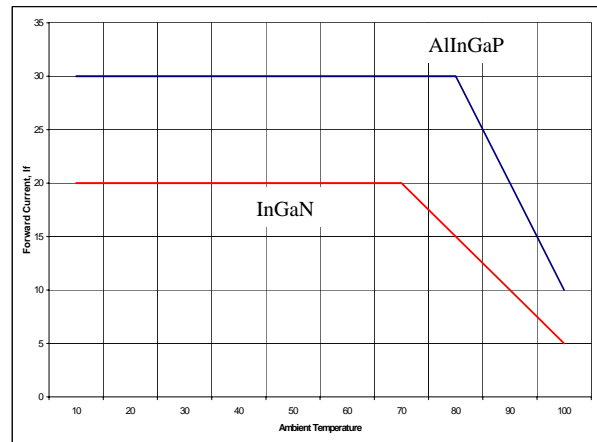

Fig. 5 Relative Intensity vs. Wavelength

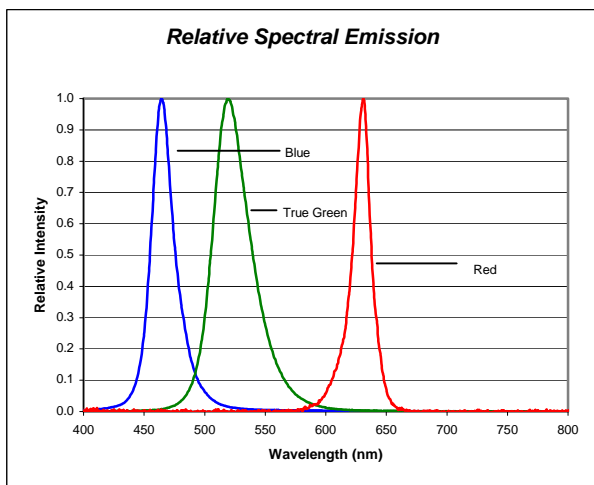

Fig. 6 Dominant Wavelength vs. Forward Current

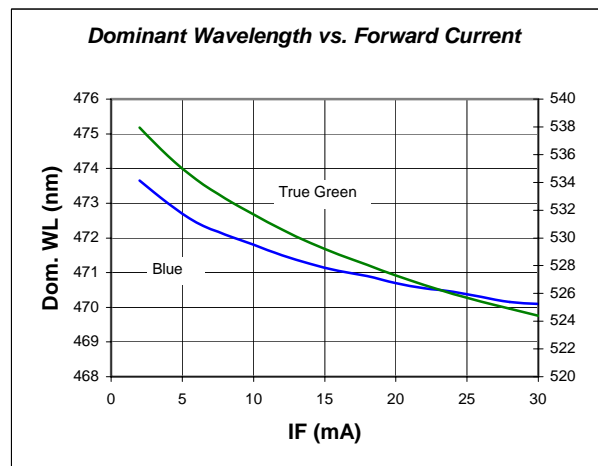



Fig. 7 Recommended IR-reflow Soldering Profile (acc. To IPC 9501).

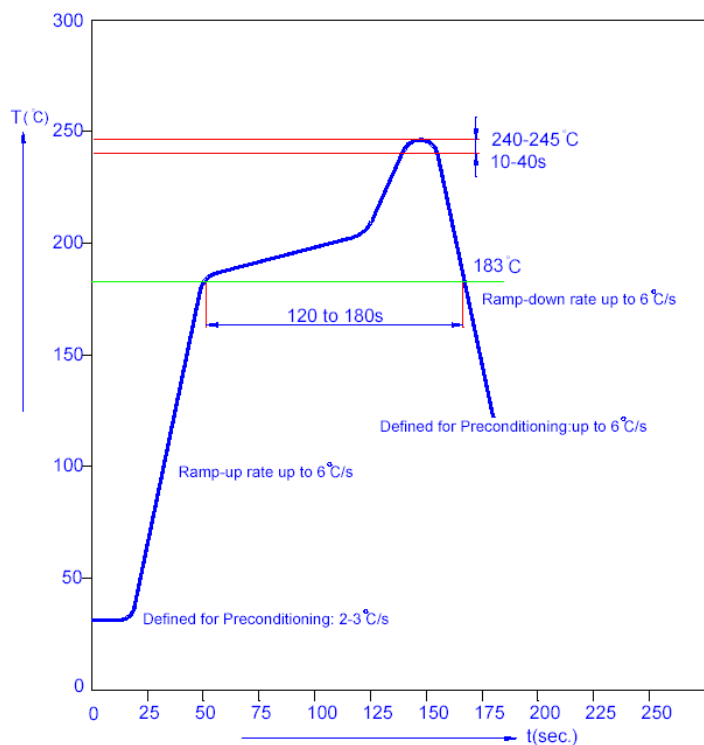
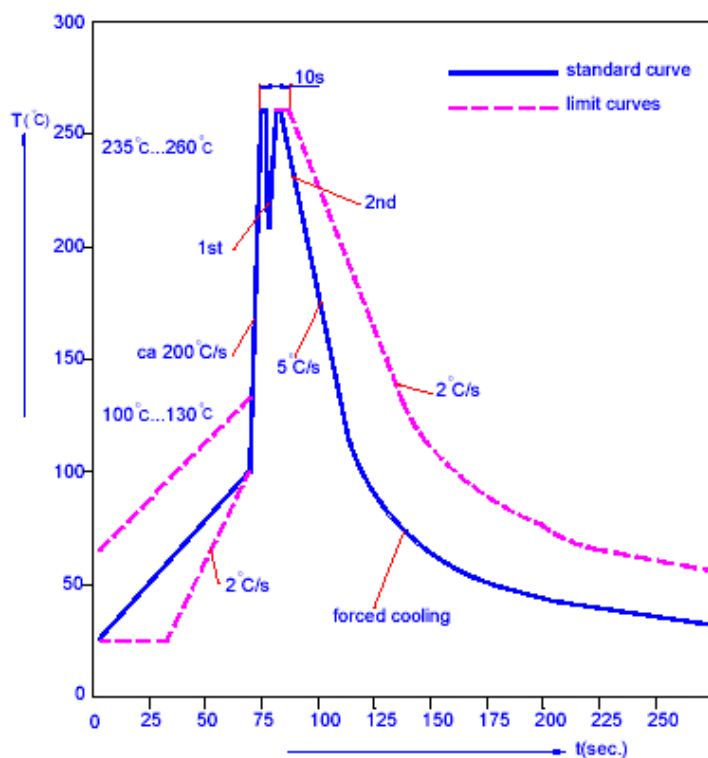

Fig. 8 Recommended TTW Soldering Profile (acc. to CECC 00802).





● Taping And Orientation:

Reels come in quantity of 8000 units or 2000 units.

Reel diameters are 330 mm and 180 mm respectively.

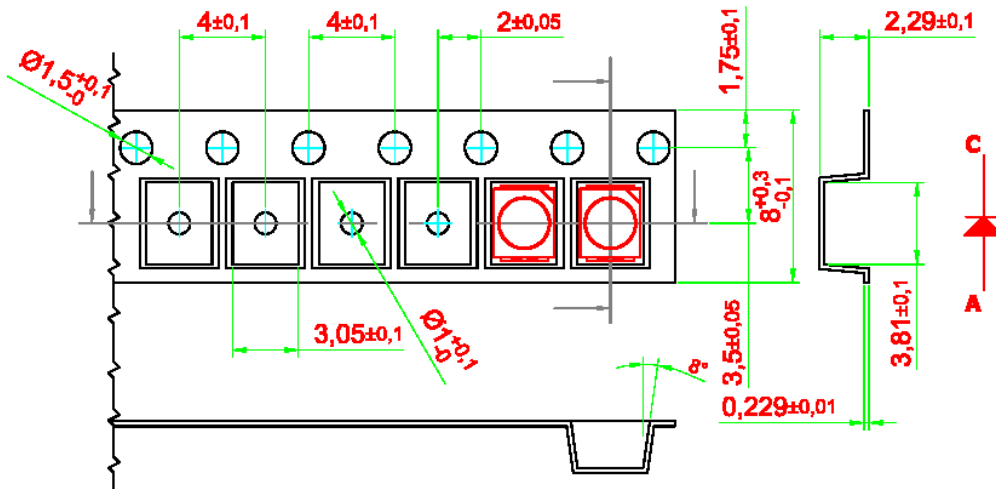

200 mm min. for  $\varnothing 180$  reel.  
200 mm min. for  $\varnothing 330$  reel.

480 mm min. for  $\varnothing 180$  reel.  
960 mm min. for  $\varnothing 330$  reel.

