

● Features:

1. Chip material: GaAsP/GaP
2. Emitted color : Hi-Eff Red
3. Lens Appearance : Red Diffused
4. For DC and pulse operation.
5. With current limiting resistor for 05V
6. TTL & CMOS compatible.
7. 5mm diameter package.
8. Internal Resistor 240Ω
9. This product don't contained restriction substance, compliance ROHS standard.

● Applications:

1. TV set
2. Monitor
3. Telephone
4. Computer
5. Circuit board

● Package Dimensions:

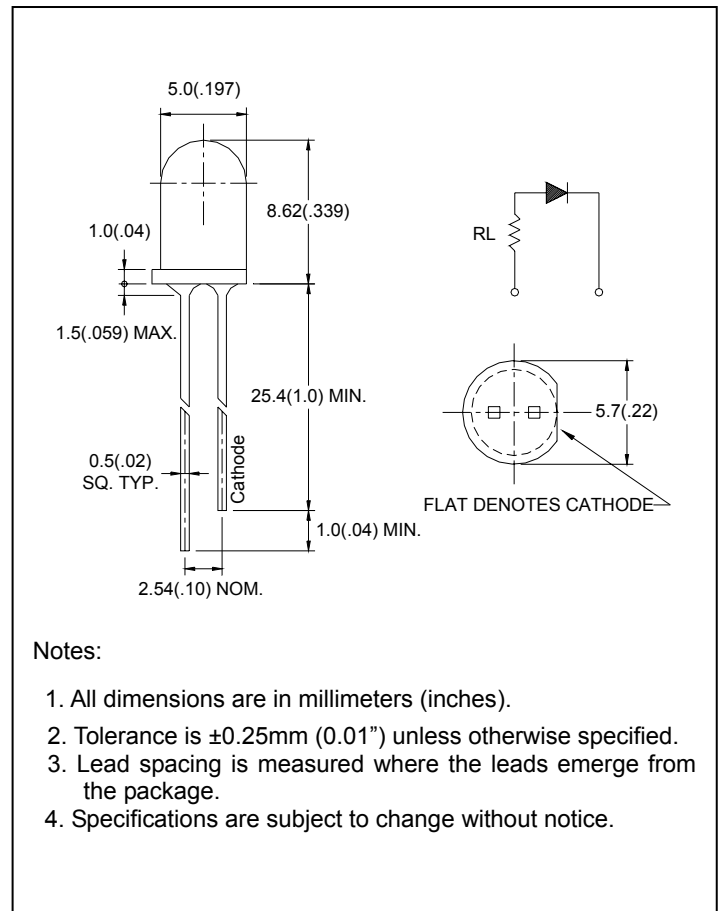

● Absolute Maximum Ratings(Ta=25°C)

Parameter	Symbol	Rating	Unit
Power Dissipation	Pd	80	mW
Peak Forward Current* ¹	I _{FP}	150	mA
Operating Temperature	Topr	-40°C~80°C	
Storage Temperature	Tstg	-40°C~85°C	
Soldering Temperature	Tsol	260°C (for 5 seconds)	

*¹Condition for I_{FP} is pulse of 1/10 duty and 0.1msec width.

● **Electrical and optical characteristics(Ta=25°C)**

Parameter	Symbol	Condition	Min.	Typ.	Max.	Unit
Forward Current	I_F	$V_F=05V$	-	8	12	mA
Luminous Intensity	I_v	$V_F=05V$	-	40	-	mcd
Peak Wave Length	λ_p	$V_F=05V$	-	640	-	nm
Dominant Wave Length	λ_d	$V_F=05V$	617	-	638	nm
Spectral Line Half-width	$\Delta \lambda$	$V_F=05V$	-	45	-	nm
Viewing Angle	$2\theta_{1/2}$	$V_F=05V$	-	35	-	deg

● **Typical electro-optical characteristics curves**

Fig.1 Relative intensity vs. Wavelength

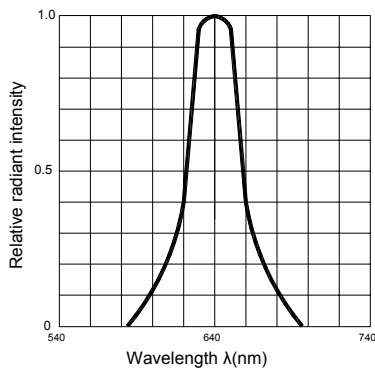

Fig.2 Forward current derating curve vs. Ambient temperature

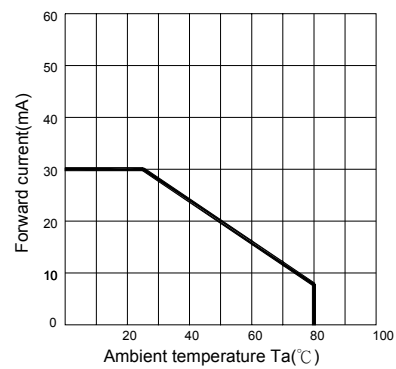

Fig.4 Relative luminous intensity vs. Ambient temperature

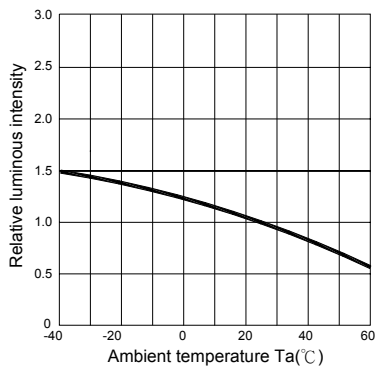

Fig.6 Radiation diagram

