

● Features:

1. Chip material: AlGaAs/GaAs
2. Emitted color : Super Red
3. Lens Appearance :Red diffused
4. Pulse Rate 2.4 Hz (VDD=5V)
5. Operating Voltage : 5V~12V (DC)
6. Easily be driven by TTL & C-MOS
circuit no external circuit needed
7. Long life solid state reliability.
8. This product don't contained restriction
substance, compliance ROHS standard.

● Applications:

1. TV set
2. Monitor
3. Telephone
4. Computer
5. Circuit board

● Package dimensions

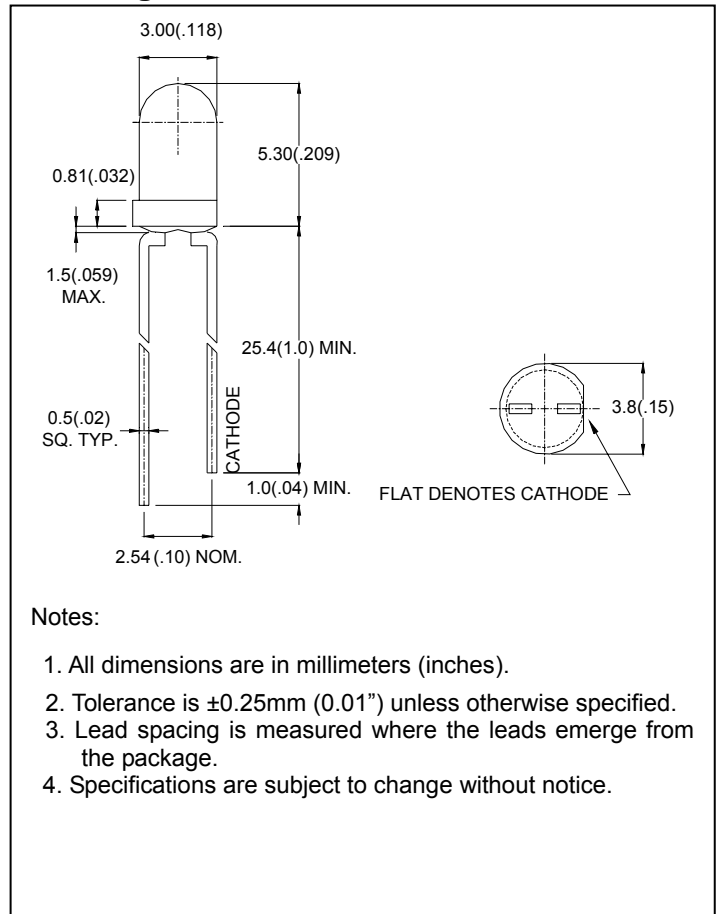

● Absolute maximum ratings(Ta=25°C)

Parameter	Symbol	Rating	Unit
Operating Voltage	V_O	12(max)	V
Reverse Voltage	V_R	5(max)	V
Operating Temperature	T_{opr}	-40°C~80°C	
Storage Temperature	T_{stg}	-40°C~85°C	
Soldering Temperature	T_{sol}	260°C (for 5 seconds)	

● Electrical and optical characteristics(Ta=25°C)

Parameter	Symbol	Condition	Min.	Typ.	Max.	Unit
Pulse Rate	Pd	VDD=5V	2.0	2.4	2.8	Hz
Luminous Intensity	Iv	I _F =20mA	-	50	-	mcd
Peak Wave Length	λ p	I _F =20mA	-	660	-	nm
Dominant Wave Length	λ d	I _F =20mA	-	643	-	nm
Spectral Line Half-width	Δ λ	I _F =20mA	-	20	-	nm
Viewing Angle	2θ _{1/2}	I _F =20mA	-	45	-	deg

● Typical electro-optical characteristics curves

Fig.1 Relative intensity vs. Wavelength

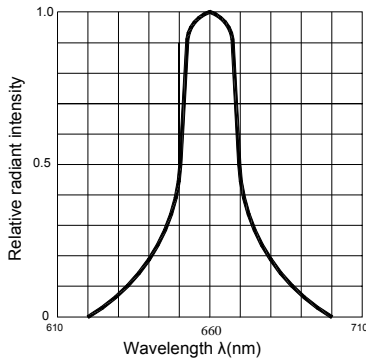

Fig.2 Forward current derating curve vs. Ambient temperature

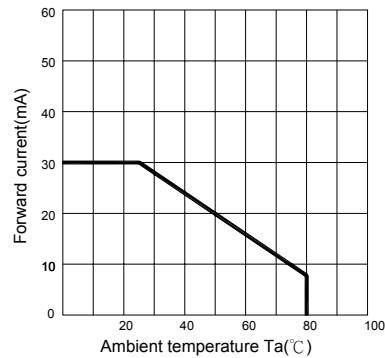

Fig.3 Forward current vs. Forward voltage

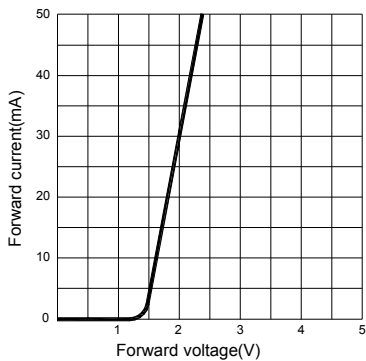

Fig.4 Relative luminous intensity vs. Ambient temperature

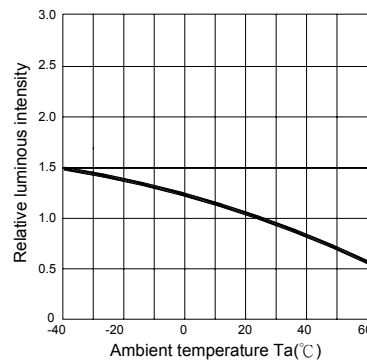

Fig.5 Relative luminous intensity vs. Forward current

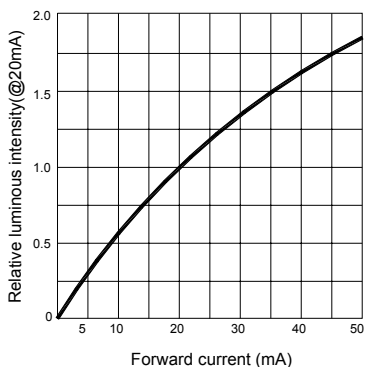

Fig.6 Radiation diagram

