

● Features:

1. Chip material: GaAsP/GaP(Red)
and GaP/GaP (Green)
2. Emitted color :Hi-Eff Red and Green
3. Lens Appearance : White Diffused
4. Low power consumption.
5. High efficiency.
6. Versatile mounting on P.C. Board or panel.
7. Low current requirement.
8. 3mm diameter package
9. This product don't contained restriction substance, compliance ROHS standard.

● Applications:

1. TV set
2. Monitor
3. Telephone
4. Computer
5. Circuit board

● Package Dimensions:

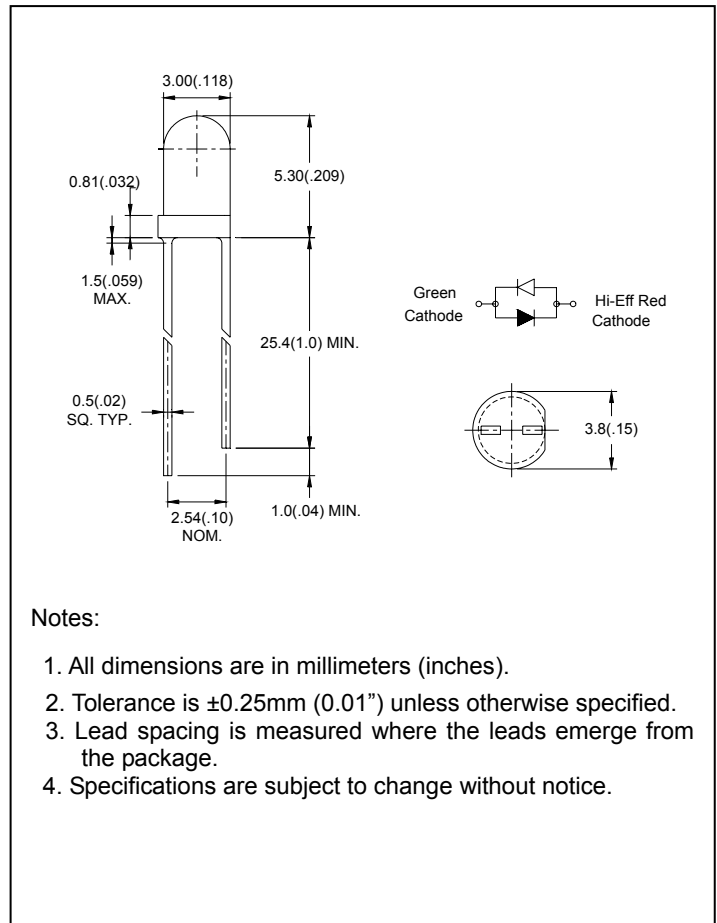

● Absolute Maximum Ratings(Ta=25°C)

Parameter	Symbol	Hi-Eff Red	Green	Unit
Power Dissipation	Pd	80	80	mW
Forward Current	I _F	30	30	mA
Peak Forward Current* ¹	I _{FP}	150	150	mA
Reverse Voltage	V _R	5		V
Operating Temperature	Topr	-40°C~80°C		
Storage Temperature	Tstg	-40°C~85°C		
Soldering Temperature	Tsol	260°C (for 5 seconds)		

*¹Condition for I_{FP} is pulse of 1/10 duty and 0.1msec width.

● Electrical and optical characteristics(Ta=25°C)

Parameter	Symbol	Condition	Color	Min.	Typ.	Max.	Unit
Forward Voltage	V_F	$I_F=20\text{mA}$	Hi-Eff Red Green	-	2.1 2.2	2.6 2.6	V
Luminous Intensity	I_v	$I_F=20\text{mA}$	Hi-Eff Red Green	-	30 30	-	mcd
Reverse Current	I_R	$V_R=5\text{V}$	Hi-Eff Red Green	-	-	100	μA
Peak Wave Length	λ_p	$I_F=20\text{mA}$	Hi-Eff Red Green	-	640 568	-	nm
Dominant Wave Length	λ_d	$I_F=20\text{mA}$	Hi-Eff Red Green	617 560	- -	638 576	nm
Spectral Line Half-width	$\Delta \lambda$	$I_F=20\text{mA}$	Hi-Eff Red Green	-	40 30	-	nm
Viewing Angle	$2\theta_{1/2}$	$I_F=20\text{mA}$	Hi-Eff Red Green	-	45	-	deg

● Typical Electro-Optical Characteristics Curves

