



# Maxiflex 2PFC Precision Frequency Counter Module

Model M1715A 2 Channel High Precision Frequency Counter Module.

DATASHEET



## FEATURES

- 2 individually Isolated Frequency Counter Channels
- Interfaces to two Vibrating Tube Densitometers
- Measures 1Hz to 5kHz at 15ppm accuracy
- Outputs period of incoming frequency in nanoseconds
- Accepts 9-30Vdc or 3 to5Vdc Pulse Input
- Fits in any MAXIFLEX base I/O slot
- 1500V rms Isolation

The M1715A high precision frequency counter module provides individually isolated field inputs to two 32-bit frequency counters. The counters are designed to operate in the range 1Hz to 5Khz and return the period in nanoseconds of each input to an accuracy of better than 15ppm.

A target application for this module is as interface to vibrating tube densitometers to allow the highest accuracy of frequency to be measured in oil and gas custody transfer applications.

Liquid density is one of the many parameters to be accurately measured for product quality control, custody transfer, process control, or liquid interface detection purposes. In the hydrocarbon industry, the vibrating tube densitometer is most common. In this type of densitometer, a tube of known mass is vibrated at its natural frequency. As the tube is filled with the process fluid, the frequency will be damped proportionate to the density of the material. Other variables, such as specific gravity,

molecular weight, Brix and concentration can be derived from this measurement if required. The mass is related to the mass of the tubing plus the mass of the fluid inside the tubing. As the mass (or density) of the fluid in the tubing varies, the natural frequency varies. Because of the relative mass of the tube to the process fluid in the tube, the measurement of frequency must be highly accurate to achieve satisfactory results. The high accuracy of the Maxiflex 2PFC module makes it ideal for this measurement application.

The 2PFC module should be used in conjunction with dedicated software to be used as part of the user application. For use with Isagraf compatible CPUs use the Omniflex supplied function block "cn74\_t". For use with Forth compatible CPUs, ask Omniflex for the necessary eziForth words.

Each input may be configured by links inside the module to either be a 3-5V dc, or a 9-30V dc input to support the widest range of densitometers.

## SPECIFICATIONS

### Input

Number	2 Frequency Inputs (Inputs 1 and 2)
Type (Two Ranges)	9-30Vdc (default) or 3-5Vdc Pulses
Input Current	Standard: 2.6mA at 9V; 10mA at 30V Low: 2.6mA at 3V; 8mA at 5V
Input Isolation	100% tested to 1500Vac for 1 minute
Insulation Resistance	1000MΩ min. at 500Vdc
Input Indication (Green LED per channel)	LED on channel Active LED off channel Inactive
Input Range	1Hz to 5kHz
Period Measurement Range	200,000 to 1,000,000,000 nanosec.

### Input Termination

Types	Screw clamp Plug-in Terminal Blocks and 20 way ribbon header
Screw Terminal Wire Size	2.0mm <sup>2</sup> maximum <i>For manageable wiring to the module, 0.5 mm<sup>2</sup> is recommended with 2mm overall outside diameter</i>

### Environmental

Operating Temperature	-25°C to +60°C (-13°F to +140°F)
Storage Temperature	-40°C to +70°C (-40°F to +158°F)
Humidity	95% max. at 40°C (104°F) non-condensing.
Protection	Electronics conformally coated

### Logic Power Consumption

From Logic Power Supply	60mA from 5Vdc max.
-------------------------	---------------------

### Auto Identification Codes

Module ID	126
Scan Code	127

### Mass

Excluding Packaging	320g (11.3oz)
Including Packaging	410g (14.5oz)

### Ordering Information

<b>Model</b>	<b>Order Code</b>
Maxiflex 2PFC	M1715A



# Maxiflex 2PFC Precision Frequency Counter Module

Model M1715A 2 Channel High Precision Frequency Counter Module.

## ELECTRICAL CONNECTION

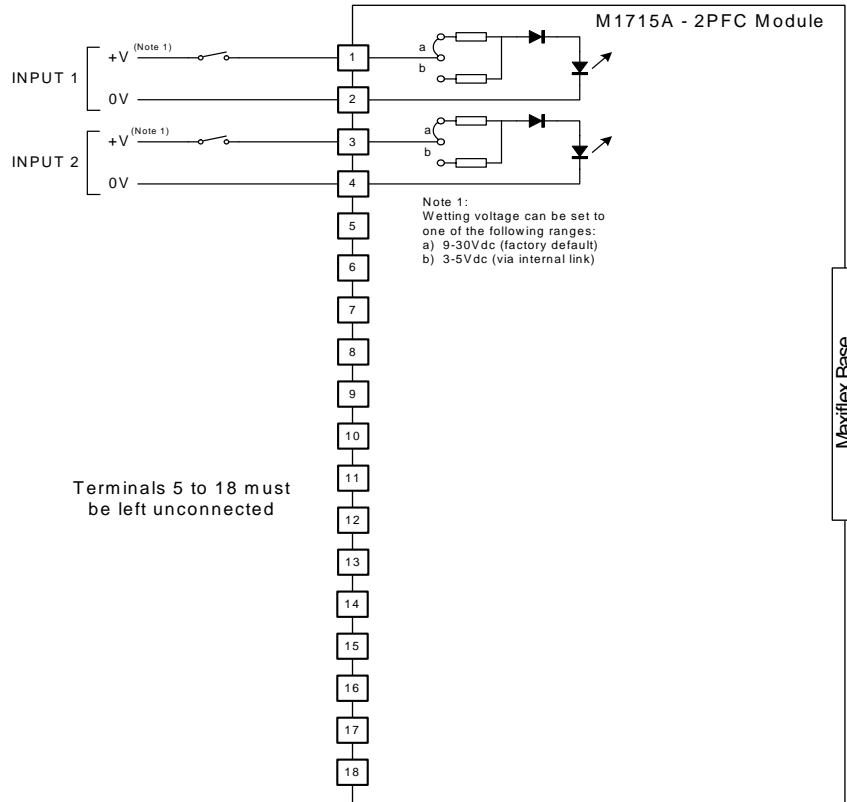

## MECHANICAL CONFIGURATION

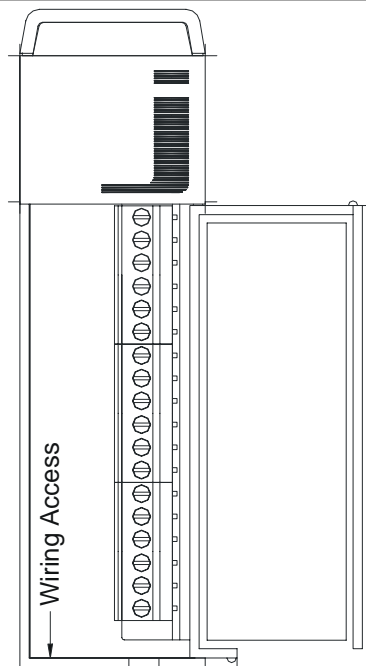

Note: Module shown with door open.