

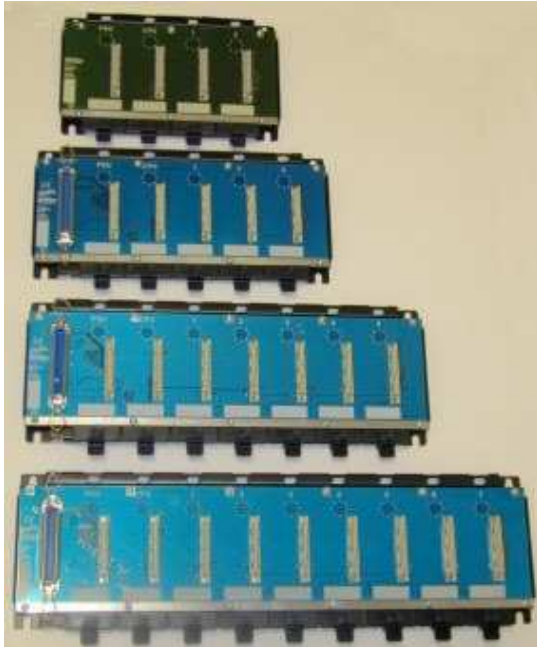

MAXIFLEX BASES

Models M1001, M1021, M1022, M1023, M1031, M1032

DATASHEET



FEATURES

- Wall- mounting
- System sizes from 2 to 15 I/O modules per CPU
- Secure easy-to-use module mounting.
- Hot Plug-in of I/O modules
- Automatic I/O module slot addressing
- Automatic I/O module type identification
- Optional module keying
- 19" frame adapter available

MAXIFLEX Bases are available in various sizes (for application flexibility and to cater for possible enclosure limitations).

These bases are designed for surface mounting but a purpose designed mounting bracket (Model M1821) facilitates mounting in a 19" frame.

Two types of base are available in this range: Master Bases and Expander Bases.

Every Master Base will accept a CPU module plus a number of I/O modules, while the Expander Bases accept only I/O modules.

The number of I/O modules accessed by the CPU on any Master Base, (except the M1001 2I/O base which does not have an expander socket), may be expanded using any one of the Expander Bases. A single

Expander Base is connected to a Master Base using the M1811 Expander Cable. This allows a maximum of 15 I/O modules to be connected to a single CPU module.

The M1811 Expander Cable is 400mm long, allowing a maximum of 180mm between the Master and Expander bases when mounted one above the other. A space of at least 100mm must be allowed between bases when mounted to allow for module insertion/removal and field wiring.

Each MAXIFLEX module is secured in position on the base by a retaining clip that is pressed to remove the module.

Each Master base in the range requires a logic power supply to power the system. An additional logic power supply is required for the 8 way expander base.

SPECIFICATIONS

Model	Description	PSU Slot	CPU Slot	I/O Slots	Expand	Weight Unpacked	Weight Packed
M1001A	2 I/O Master Base	1	1	2	No	410g (14.5oz)	500g (17.7oz)
M1021B	3 I/O Master Base	1	1	3	Yes	560g (19.8oz)	675g (23.8oz)
M1023B	5 I/O Master Base	1	1	5	Yes	710g (25.0oz)	890g (31.4oz)
M1022B	7 I/O Master Base	1	1	7	Yes	800g (28.2oz)	960g (33.8oz)
M1031B	5 I/O Expander Base	None	None	5	-	560g (19.8oz)	675g (23.8oz)
M1032B	8 I/O Expander Base	1	None	8	-	800g (28.2oz)	985g (34.7oz)

Environmental

Operating Temperature: -25°C to +60°C (-13°F to +140°F)

Storage Temperature: -40°C to +70°C (-40°F to +158°F)

Humidity: 95% max. at 40°C (104°F) non-condensing.

Vibration: 10m/s² (1G) 10Hz – 150Hz



MAXIFLEX BASES

Models M1001, M1021, M1022, M1023, M1031, M1032

MECHANICAL DIMENSIONS

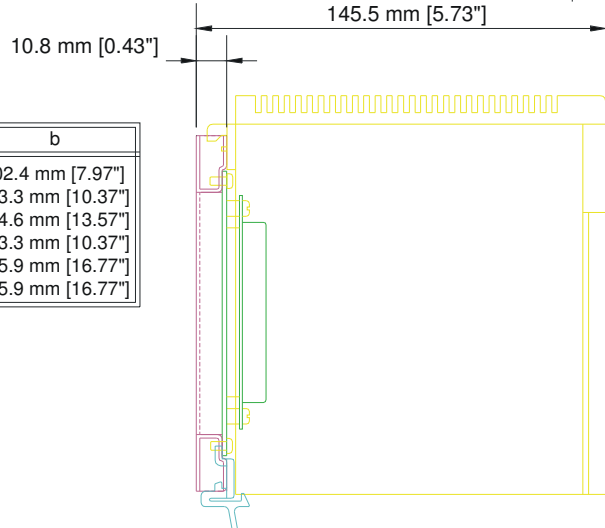
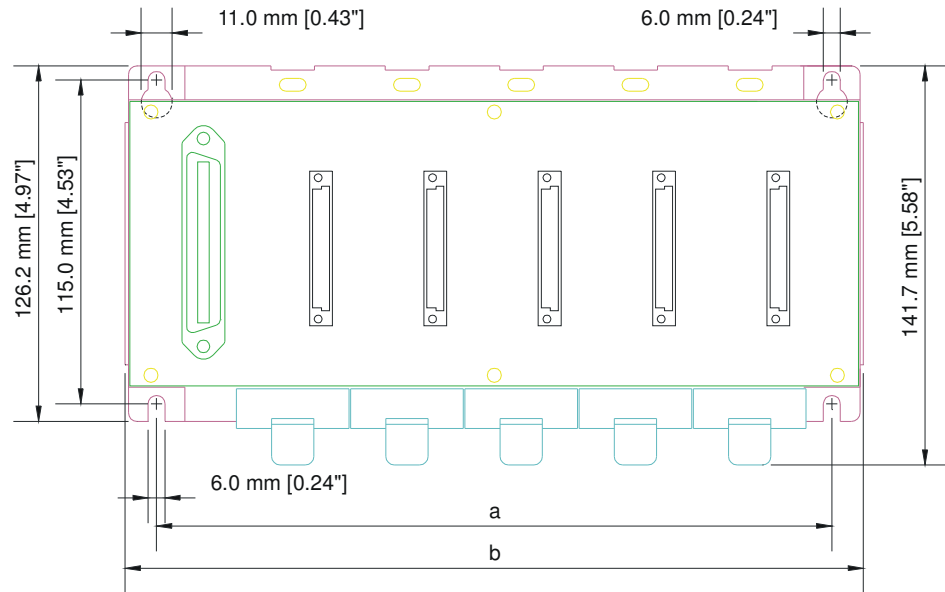

Model No.	Description	a	b
M1001A	2 I/O Master	180.0 mm [7.09"]	202.4 mm [7.97"]
M1021A	3 I/O Master	241.0 mm [9.49"]	263.3 mm [10.37"]
M1023A	5 I/O Master	322.2 mm [12.69"]	344.6 mm [13.57"]
M1031A	5 I/O Expander	241.0 mm [9.49"]	263.3 mm [10.37"]
M1022A	7 I/O Master	403.5 mm [15.89"]	425.9 mm [16.77"]
M1032A	8 I/O Expander	403.5 mm [15.89"]	425.9 mm [16.77"]



MAXIFLEX BASES

Models M1001, M1021, M1022, M1023, M1031, M1032

SYSTEM INSTALLATION

