

PanelX™ 50mm Trackball

DESCRIPTION

Designed for demanding industrial environments, PanelX builds on the proven design of Pretorian Technology's PanelPro™ panel mounting trackballs. They incorporate a PanelPro 50mm trackball into a convenient brushed stainless steel fascia for easy mounting into a larger panel.

Industry-standard fixing centres via four welded studs ensure that the unit may be retro-fitted into existing applications.

The unit incorporates three buttons which can be factory wired according to the application requirements, and benefits from an attractive brushed stainless steel fascia.

PanelX is the only pointing device family to combine all of the connection formats (protocols) used in modern computer systems into a single unit. Units are capable of phase quadrature, USB, PS/2, Microsoft, Sun and Mouse Systems formats. Quadrature (X and Y) outputs are available simultaneously with any one of the remaining formats.

Each unit has the option of a self-adjusting seal around the ball which affords the unit an IP65/NEMA 4 rating whilst ensuring that the ball tracks smoothly and accurately under all operating conditions. A gasket between the trackball body and the fascia ensures that the overall seal rating is not compromised.

A robust, durable metal bezel may be fitted to the unit in contrasting black anodised aluminium or in stainless steel. A shock-transmission plate may also be fitted to the unit to protect from abuse.

The left, middle and right buttons may be configured for latching functions. The latches may be programmed (using a DIP Switch) to operate instantaneously when the button is pressed, or after approximately one second of the button being pressed.

Additionally, the buttons may be wired in any order on request. For example, two buttons wired as 'left click' and one as 'right click' etc.

A facility is also provided to connect a scroll wheel, similar to that on a 'wheel mouse', giving pan, zoom and scroll features in numerous software packages.

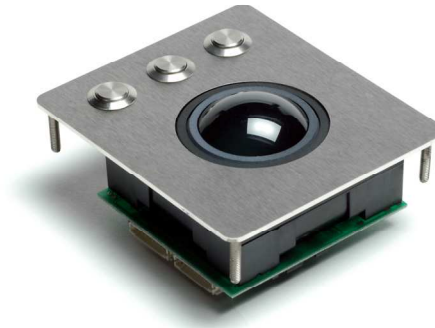

Model shown: T550BE1A3

In USB and PS/2 formats, an extended feature set may be enabled (using a DIP Switch), allowing an optional buzzer to indicate when a button latch is engaged and disengaged.

Each unit is shipped with either a 2 metre PS/2 or USB cable. Other cables are available as accessories- see Page 5 for ordering options.

All units are shipped with a comprehensive Data Log which provides a hard-copy of the tests performed by the Automatic Test Equipment.

The trackball incorporated into PanelX is exactly the same as the PanelPro range from Pretorian Technologies. Please refer to PanelPro data sheets for complete information on trackball configuration and features.

FEATURES

- Durable 50mm phenolic resin or solid stainless steel ball.
- Attractive brushed stainless steel fascia.
- Three buttons (fewer buttons to special order).
- IP65 (NEMA 4) or IP40 (NEMA 2) sealing.
- Phase Quadrature, USB, PS2, Microsoft, Sun and Mouse Systems protocols from a single unit.
- Z-axis inputs for scroll wheel operation.

APPLICATIONS

- Industrial process control.
- Medical equipment.
- Air traffic control/ marine/ radar equipment.
- Studio equipment.

SPECIFICATIONS

Mechanical

Weight	440 grams (without bezel) 450 grams (with metal bezel) (Add 420 grams where stainless steel ball fitted)
Ball dimensions	50.8mm \pm 0.05mm
Tracking force	50g nominal- any direction (tangential to ball)
Ball speed	250 rpm maximum
Seal material	PTFE with low friction fill
Ball material	Phenolic resin or stainless steel 440
Body material	PC/ABS
Bezel material	Black anodised aluminium or stainless 303
Shaft material	Stainless 303
Fascia material	Stainless 316S31
Mounting torque (M4 bolt, washer and nut, 3 locations)	40 Ncm

Electrical

Supply voltage	5.0V dc \pm 10%
Resolution	150 pulses/ball revolution 600 counts/ball revolution
Switch debounce	30ms rising and falling
Supply current (quadrature)	5mA maximum
Supply current (protocol)	15mA maximum
Supply current (with backlight)	100mA maximum
Supply current (USB Suspend Mode)	450 μ A maximum
Button pullup resistors	7k Ω nominal
Z1, Z2 pullup resistors	100k Ω nominal.
Maximum voltage connected to button and Z1, Z2 inputs	5.5V dc
Minimum voltage connected to button and Z1, Z2 inputs	-0.7V dc
Maximum backlight current per colour	50mA
Maximum voltage connected to J4	5.5V dc.
Minimum voltage connected to J4	-0.7V
Minimum output high voltage X1,X2, Y1, Y2, Data, Clk	4.5V
Maximum output low voltage X1, X2, Y1, Y2, Data, Clk	0.8V
Piezo buzzer nominal sound pressure	88dB at 0.1m

Buttons

Type	16mm Anti-vandal
Body Material	Nickel plated brass and PBT
Operating temperature	-20°C to +55°C
Switch rating	200mA at 48V dc
Switch life	1 000 000 cycles

Trackball Environmental

Storage temperature	-25°C to +85°C
Operating temperature	0°C to +70°C
Humidity	95% rh, non-condensing, maximum
Vibration	5G, sinusoidal, 2-5kHz (swept), any plane
Static ball load	1000N maximum
Shock ball load	10J maximum- single blow
Lifetime	10 million ball revolutions minimum

MOUNTING DETAILS

Note that an *IGES* model of this unit is available on the Pretorian Technologies website- www.pretorianuk.com. This model contains only the outer detail but is sufficient to allow the model to be incorporated into a 3D model of the target equipment to ensure correct fitting.

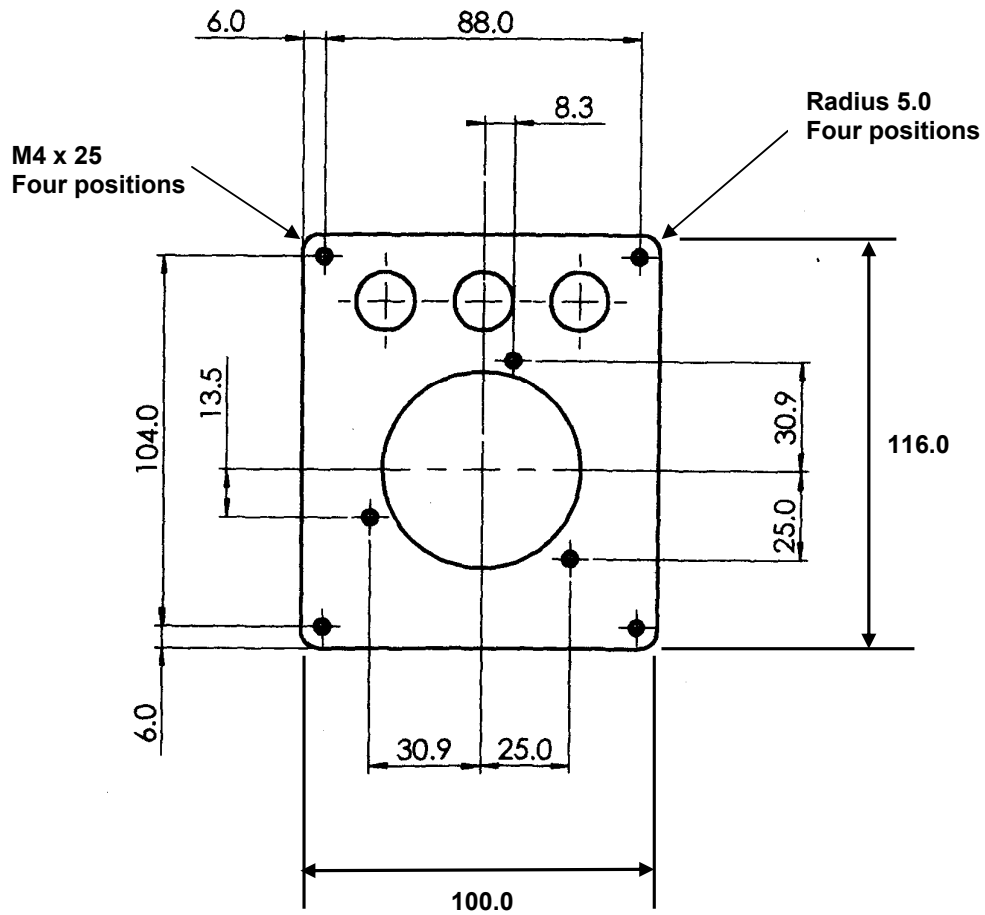

Panel thickness is 2.0mm.
Grain direction is north-south.

ORDERING INFORMATION

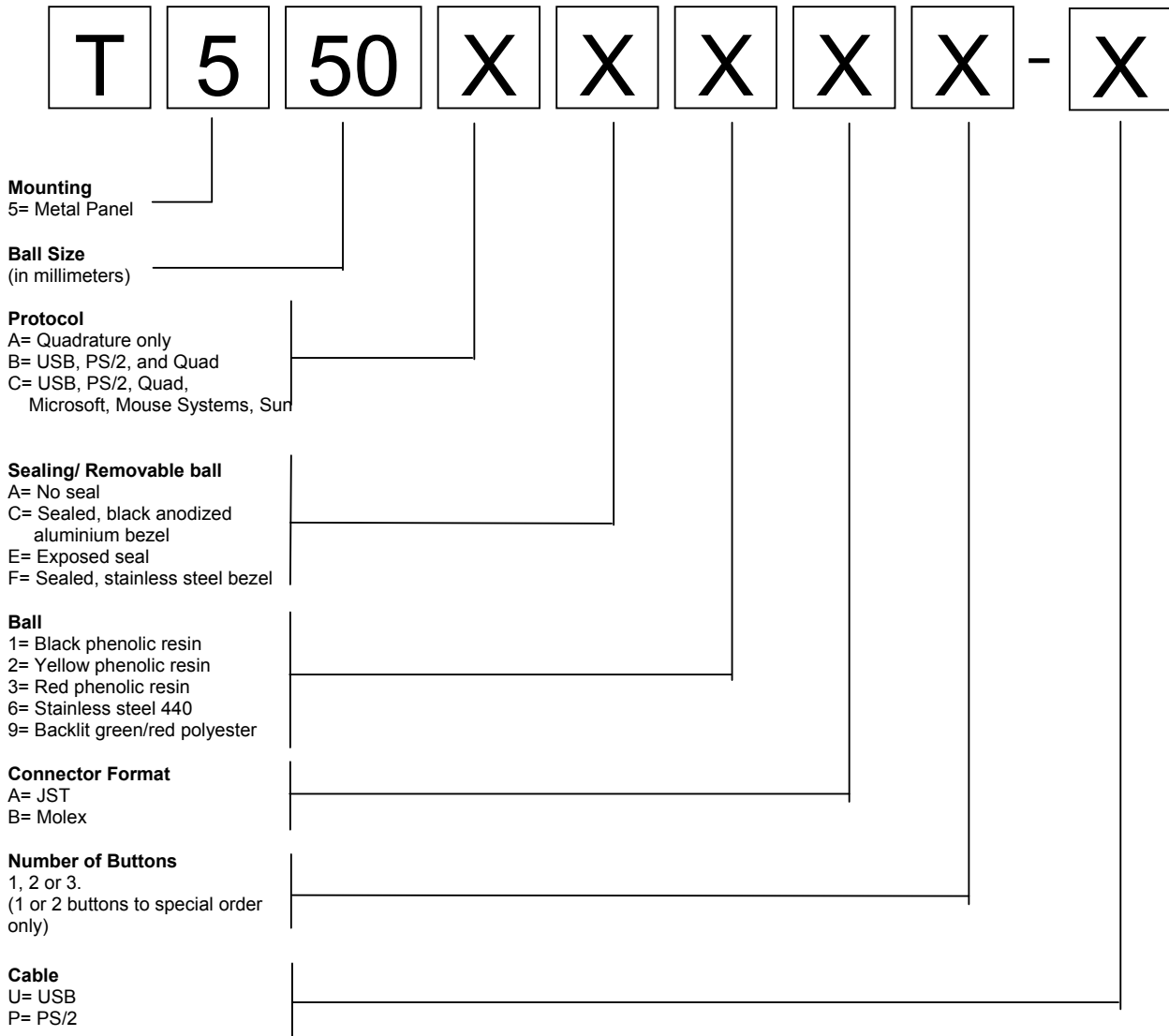

Examples:

The following are common order code examples:

T550BC1A3-U 50mm PanelX, PS2/USB output, IP65 with black anodised bezel, black phenolic ball, JST connectors, three buttons. Supplied with a USB cable.

T550BE1A3-P 50mm PanelX, PS2/USB output, IP65 with no bezel, black phenolic ball, JST connectors, three buttons. Supplied with a PS/2 cable.

OPTIONAL EXTRAS

Shock transmission (anti-vandal) plate- 50mm (order code X199001)
2m Lead assembly USB (order code X199003)
2m Lead assembly PS/2 (order code X199004)
2m Lead assembly RS232 (order code X199005)
Adaptor plug USB → PS2 (order code X199006)
0.5m Lead assembly buttons (order code X199012)
0.5m Lead assembly buttons/wheel (order code X199007)

Whilst the information provided herein is to the best of our knowledge true and accurate, it is provided for guidance only. You are strongly advised to ensure that the information provided is up to date. This document does not constitute any part of a contract unless expressly agreed in writing. Use of Pretorian Technologies Ltd. products in life support systems is not permitted except with the express written approval of the Company.

Copyright in this document is vested in Pretorian Technologies Ltd. All rights reserved. No unauthorised copying, transmission or storage in retrieval systems except as permitted by relevant copyright law. All other trade names and trademarks mentioned herein are the property of their respective owners.