

PanelPro™ 50mm Protocol Output Trackball

DESCRIPTION

The Pretorian Technologies Ltd. PanelPro™ range of Trackball products is a high-precision family of pointing devices which combines advanced features with extremely high build quality for the most demanding professional, industrial and military environments.

PanelPro is the only pointing device family to combine all of the connection formats (protocols) used in modern computer systems into a single unit. Units are capable of phase quadrature, USB, PS/2, Microsoft, Sun and Mouse Systems formats. Quadrature (X and Y) outputs are available simultaneously with any one of the remaining formats. This allows a single unit to operate with virtually any modern computer system, reducing inventory and minimising commissioning time.

Each unit has the option of a self-adjusting seal around the ball which affords the unit an IP65/NEMA 4 rating whilst ensuring that the ball tracks smoothly and accurately under all operating conditions.

Units may also benefit from a robust, durable metal bezel. This is normally manufactured from black anodised aluminium.

In public access and highly ruggedised applications where misuse is likely, a stainless steel bezel and shock-transmission plate may be fitted.

Five buttons are available when using the extended functionality of USB and PS/2 formats. This feature is fully supported by Windows 2000, XP and later. All buttons may be configured for a number of different purposes when used with these drivers.

Additionally, the left, middle and right buttons may be configured for latching functions. The latches may be programmed (using a DIP Switch) to operate instantaneously when the button is pressed, or after approximately one second of the button being pressed.

PanelPro units are also available with a translucent, colourless ball which may be backlit.



Model shown: T150BC1A

A facility is also provided to connect a scroll wheel, similar to that on a 'wheel mouse', giving pan, zoom and scroll features in numerous software packages.

In USB and PS/2 formats, an extended feature set may be enabled, allowing an optional buzzer to indicate when a button latch is engaged and disengaged.

All units are shipped with a comprehensive Data Log which provides a hard-copy of the unit's quadrature phase angle and all other tests which are performed by in-house Automatic Test Equipment.

FEATURES

- Durable 50mm phenolic resin, polyester or stainless steel ball.
- IP65 (NEMA 4) and IP40 (NEMA 2) sealing options.
- Public-access versions with stainless steel bezel and shock-transmission plate.
- Phase Quadrature, USB, PS2, Microsoft, Sun and Mouse Systems protocols from a single unit.
- Z-axis inputs for scroll wheel operation.
- Five button support with most protocols.
- Backlight and piezo-sounder features for audio-visual feedback.

APPLICATIONS

- Medical equipment.
- Specialist keyboards.
- Industrial process control.
- Air traffic control/ marine/ radar equipment.
- Studio equipment.

CONFIGURATION

The PanelPro range boasts many features which may be selected using an 8-way DIP Switch located on the circuit board. Table 1 shows the function of each switch, and the remainder of this section describes each feature in detail:

DIP Sw	Function	Off	On
1	Orientation 1	See Table 3	See Table 3
2	Orientation 2	See Table 3	See Table 3
3	Left Button Latch	Off	On
4	Middle Button Latch	Off	On
5	Right Button Latch	Off	On
6	Latch Mode	Immediate	Delayed
7	Protocol 1	See Table 2	See Table 2
8	Protocol 2	See Table 2	See Table 2

Table 1: DIP Switch functionality

Protocol

Refer to Table 2. For USB or PS/2 operation, the unit should be configured with DIP7 and DIP8 set to 'off'. The unit then automatically recognises the connection format when power is first applied. This auto-detection works even if the unit is hot-plugged into the host computer.

To switch the unit into RS232 (serial) operation, set DIP8 to 'on' and then select the particular protocol using DIP7. If the latter is set to 'off', the unit is configured for Microsoft (4-byte) operation and with it 'on' the unit is configured for Sun/ Mouse Systems (5-byte) operation.

Sun and Mouse Systems are essentially identical except for the transmission voltages. The PanelPro circuitry automatically adjusts to the correct voltages with no user intervention.

In certain systems such as Thin-Clients, it may be necessary to manually switch the unit into PS/2 mode by setting DIP7 on and DIP8 off.

Note that quadrature outputs (X1, X2, Y1, Y2) are available simultaneously with whichever output protocol has been selected.

DIP7 and DIP8 are read by the on-board microprocessor only at power-up. Ensure that this switch is set appropriately before applying power. All other switches are continuously scanned.

Protocol 2 (DIP Sw 8)	Protocol 1 (DIP Sw 7)	Selected protocol
Off	Off	Auto-selects between USB and PS2
Off	On	PS/2 only
On	Off	Microsoft 4-byte protocol
On	On	Sun/ Mouse Systems 5-byte protocol

Table 2: Protocol selection

Orientation

The purpose of the orientation DIP Switch settings is to allow the unit to be mounted in one of four positions to suit the application. In particular, the positioning of the connectors can be selected to suit the layout of the wiring harnesses etc.

Table 3 gives full details of the DIP Switch settings and which quadrant the unit should be oriented in to give correct operation.

Orientation2 (DIP Sw 2)	Orientation 1 (DIP Sw 1)	Unit orientation (when viewed from top)
Off	Off	Connector at 9 o'clock
Off	On	Connector at 12 o'clock
On	Off	Connector at 3 o'clock
On	On	Connector at 6 o'clock

Table 3: Orientation functionality

Button Latches

A number of DIP Switches are allocated to the button latch features to afford the user maximum flexibility. The left, middle and right buttons may be individually programmed to exhibit latching functionality- see DIP Switches 3, 4 and 5 in Table 1. Note that buttons 4 and 5 may not be programmed to latch.

DIP Switch 6 selects the latch mode. With this DIP Switch 'off', a button will latch as soon as it is pressed and with the DIP Switch 'on', a button will latch if it is held down for 0.8 seconds.

For example, if DIP Switches 3, 4 and 6 were on, this would set the left and middle buttons to delayed latching mode and the right button to momentary mode.

The unit may also be configured to give a 'draglock' function where a single press of the middle button latches the left button. This is achieved by setting DIP Switches 3,4 and 5 to 'off' and DIP Switch 6 to 'on'.

Regardless of the latch mode, a latch condition may be canceled by pressing *any* button momentarily.

BUZZER/ BACKLIGHT FEATURES

The backlight and piezo-sounder features are available only in USB and PS/2 protocols due to supply current limitations in RS232 modes.

When the unit is first configured and available for use, the backlights fade from off to full brightness (green) and the piezo-sounder emits a long beep.

Whenever a latch is engaged the piezo-sounder issues a two tone beep (low to high). Disengaging the latch issues a different two tone beep (high to low).

The buzzer is fitted to the unit only on request- please contact your local Sales Office.

CONNECTION DETAILS

Main connectors

Connection to the unit is afforded by means of three latching JST connectors:

- J1 is the output connector for Quadrature, USB and PS/2 protocols (10-way).
- J2 is the button and scroll wheel (Z-axis) connector (10-way).
- J3 is the RS232 output connection for Microsoft, Sun and Mouse Systems protocols (6-way).

Pin	J1 Function	J2 Function	J3 Function
1	X1 output	Z-axis power (5V)	Tx
2	X2 output	Z1 input	Rx
3	Y1 output	Z2 input	DTR
4	Y2 output	Z-axis return	RTS
5	DRAIN	Button 5	0V
6	TEST	Button 4	+5V (Sun supply)
7	+5V	Button 1 (L)	
8	D-/DATA	Button 2 (M)	
9	D+/CLK	Button 3 (R)	
10	0V	0V	

Table 4: Main connector details

Suitable lead assemblies are available from Pretorian Technologies Ltd.- please contact your local sales office.

Notes:

All connectors are JST right-angled type-PH headers with 2mm pitch. Mating connectors are PH, CR or KR types.

All button inputs are pulled to +5V by approximately 7kΩ.

Both Z-axis inputs are pulled to +5V by 100kΩ and are passed through Schmitt triggers on the main circuit board. The Z-axis is unavailable in Sun/Mouse Systems protocols.

Buttons 4 and 5 are unavailable in Microsoft, Mouse Systems and Sun protocols.

The Z-axis return is not simply connected to 0V. This connection allows the Z-axis encoder to be powered down in USB Suspend mode.

No connection should be made to the TEST pin on J1. This is reserved for factory test purposes only.

Backlight connectors

Under normal circumstances the backlights derive their power from the host computer's supply and are controlled by the on-board microprocessor at all times.

Under certain circumstances, it may be desirable for the power and control to be derived from elsewhere, for example if backlighting is required when using an RS232 protocol. This is made possible with the provision of J4 (2-way Molex KK header- right angled).

The pin-out of J4 is given in Table 5:

Pin	J4 Function
1	Backlight 1 (normally green)
2	Backlight 2 (normally red)

Table 5: J4 connector details

Notes:

J4 is not normally fitted. However, suitable Molex KK connectors are widely available.

It is *essential* that R12 and R20 on the circuit board are removed before connecting to J4, otherwise damage to the on-board backlight circuit may result. It is also essential that suitable current limiting resistors are used to set LED brightness.

The 0V connection on J4 must be common with the main 0V.

Please refer to AN0011 for further information.

MECHANICAL FEATURES

The PanelPro range of Trackballs benefits from a number of mechanical features which make the units more robust:

Ball Seal

The unit may optionally be fitted with a self-adjusting seal which maintains contact with the ball at all times and prevents ingress of liquids and foreign matter.

The profile of the seal has been carefully determined by Pretorian Technologies to optimize the sealing capabilities whilst minimising wear. A very low friction material is used to help minimise the drag.

When fitted, the seal affords the unit an IP65 (NEMA 4) rating whilst the ball is static. When the ball is revolving, the rating is reduced to IP54 (NEMA 3). Units not fitted with a seal have an IP40 (NEMA 2) rating.

Ball Skirt

This is a means for ensuring that any liquids or foreign matter which do enter the unit are kept away from the sensitive circuit board. The cavity in which the ball sits is effectively elongated such that any liquid which enters the unit runs down the inner walls and off the ball skirt, well away from the circuit board. This prevents 'leeching' of liquids between the circuit board and plastic body by capillary action, which can cause corrosion.

Ball Colour Options

The colour of the ball may be specified in the order code (see Page 7) to suit any application. Solid coloured balls (black, red and yellow) are manufactured from thermoset phenolic resin and translucent balls from polycarbonate.

Public Access/Ruggedised Applications

For high usage, public-access applications or where the Trackball is likely to be subjected to extreme abuse- such as point of information (POI) terminals and internet kiosks- all units may be fitted with a stainless steel ruggedised bezel and shock-transmission plate.

The shock-transmission plate fixes to the base of the Trackball using the standard fixing bosses. Consequently it does not require any extra panel holes or studs. It is manufactured from thick stainless steel and is designed to allow a minimum of clearance between the ball and the plate. A heavy blow to the ball causes the ball to contact the plate and so doing transmits the energy via the mounting studs to the panel on which the unit is mounted. This prevents the energy being transmitted to the shafts, bearings, and mouldings and causing damage.

The stainless steel bezel completely shrouds the sensitive ball seal to prevent damage from knife attack.

Stainless steel units may be supplied with or without an IP65 seal.

Face Gasket

All units are supplied with a closed-cell gasket which forms a liquid-tight seal between the customer's panel and the Trackball mouldings.

Packaging

All Pretorian 50mm Trackballs are supplied in anti-static bags within a re-usable, bio-degradable cardboard box with dimensions 96 x 92 x 85mm. These boxes have a false bottom and an upper cardboard insert to give added protection during shipping.

SPECIFICATIONS

Mechanical

Weight	260 grams (phenolic ball) 670 grams (stainless steel ball, stainless steel bezel)
Ball dimensions	50.8mm ±0.05mm
Tracking force	50g nominal- any direction (tangential to ball)
Ball speed	250 rpm maximum
Seal material	PTFE with low friction fill
Ball material	Phenolic resin, polyester pr stainless 420
Body material	PC/ABS
Bezel material	Black anodised aluminium or stainless 303
Shaft material	Stainless 303

Electrical

Supply voltage	5.0V dc ±10%
Resolution	150 pulses/ball revolution 600 counts/ball revolution
Switch debounce	30ms rising and falling
Supply current (quadrature)	5mA maximum
Supply current (protocol)	15mA maximum
Supply current (with backlight)	100mA maximum
Supply current (USB Suspend Mode)	450µA maximum
Button pullup resistors	7kΩ nominal
Z1, Z2 pullup resistors	100kΩ nominal.
Maximum voltage connected to button and Z1, Z2 inputs	5.5V dc
Minimum voltage connected to button and Z1, Z2 inputs	-0.7V dc
Maximum backlight current per colour	50mA
Maximum voltage connected to J4	5.5V dc.
Minimum voltage connected to J4	-0.7V
Minimum output high voltage X1,X2, Y1, Y2, Data, Clk	4.5V
Maximum output low voltage X1, X2, Y1, Y2, Data, Clk	0.8V
Piezo buzzer nominal sound pressure	88dB at 0.1m
MTBF (25°C Ground Benign)	240750 hours

Environmental

Storage temperature	-25°C to +85°C
Operating temperature	0°C to +70°C
Humidity	95% rh, non-condensing, maximum
Vibration	5G, sinusoidal, 2-5kHz (swept), any plane
Static ball load	1000N maximum
Shock ball load	10J maximum- single blow
Lifetime	10 million ball revolutions minimum

COMPATIBILITY

The Panel Pro Trackball range has been tested for compatibility with the following operating systems. Refer to AN0003 and AN0008 for further details.

Windows- all versions up to and including Windows 7.

Redhat Linux

Apple MacOS

Sun Sparc

Passes USB 1.1 Chapter 9 and HIDview

MOUNTING DETAILS

Note that an IGES model of this unit is available on the Pretorian Technologies website- www.pretorianuk.com. This model contains only the outer casing detail but is sufficient to allow the model to be incorporated into a 3D model of the target equipment to ensure correct fitting.

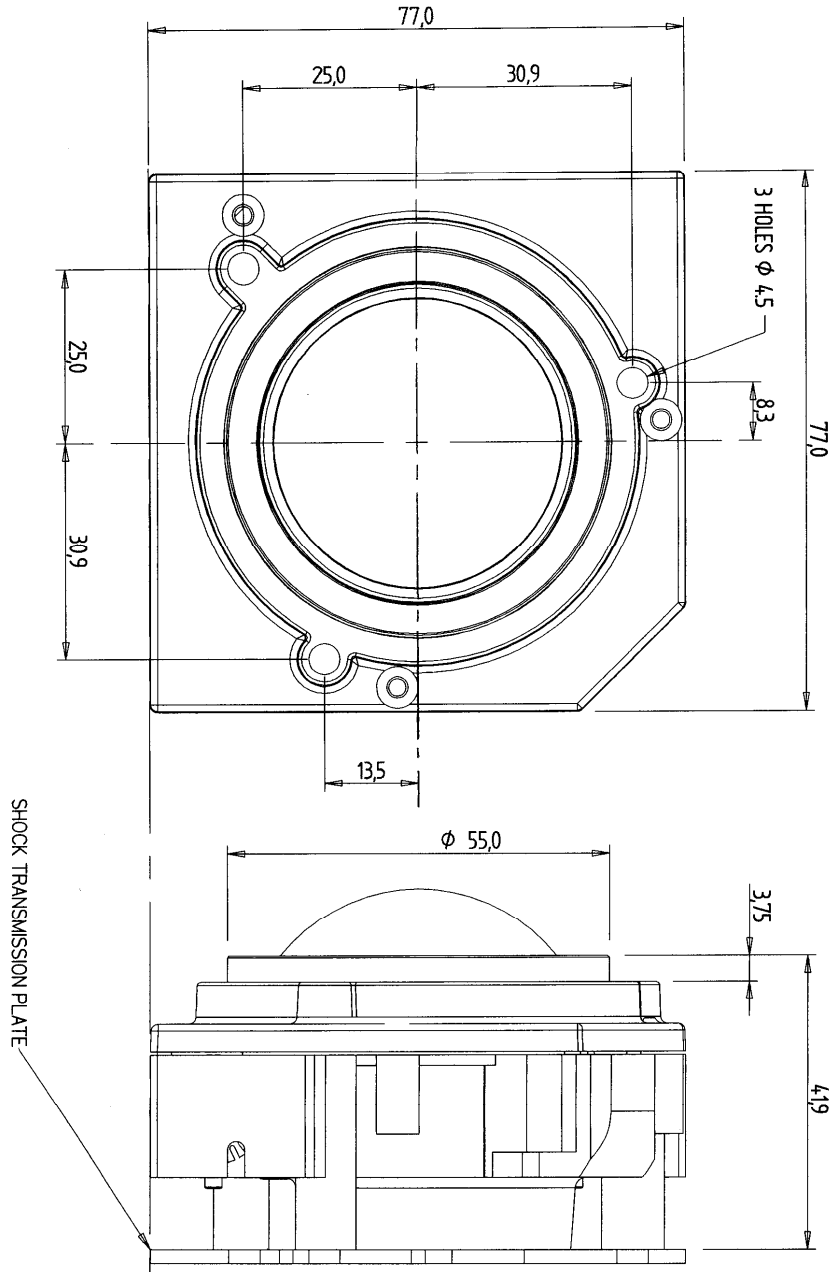

Note: Shock transmission plate is optional
Bezel height is dependent on choice of bezel type. Contact us for more details.

ORDERING INFORMATION

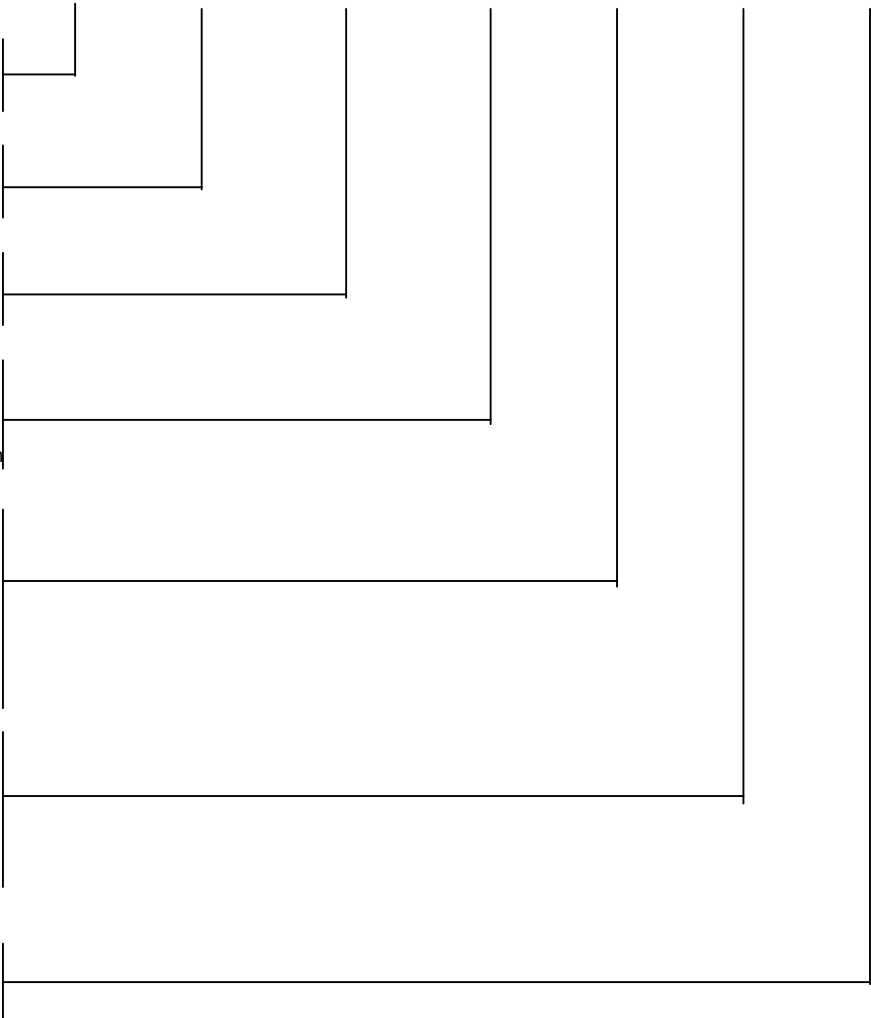
	T	1	50	X	X	X	X
Product Range T= PanelPro							
Mounting 1= Panel							
Ball Size (in millimeters)							
Protocol A= Quadrature only B= USB, PS/2, and Quad C= USB, PS/2, Quad, Microsoft, Mouse Systems, Sun							
Sealing/ Removable ball A= No seal C= Sealed, black anodised aluminium bezel E= Exposed seal F= Sealed, stainless steel bezel							
Ball 1= Black phenolic resin 2= Yellow phenolic resin 3= Red phenolic resin 6= Solid stainless steel (440) 9= Backlit green/red polyester							
Connector Format A= JST B= Molex							

The following are common order code examples:

- T150AC1A** 50mm, Phase Quadrature only output, IP65 seal, black anodised bezel, black ball, JST connectors.
- T150BE1A** 50mm, USB, PS/2 and Quadrature output, exposed seal, black ball, JST connectors.
- T150BF6B** 50mm, USB, PS/2 and Quadrature output, IP65 seal, stainless steel bezel, stainless steel ball, Molex connectors.
- T150CF6A** 50mm, USB, PS/2, Microsoft, Mouse Systems & Sun output, IP65 seal, stainless steel ball and bezel, JST connectors

OPTIONAL EXTRAS

Shock transmission (anti-vandal) plate- 50mm (order code X199001)
2m Lead assembly USB (order code X199003)
2m Lead assembly PS/2 (order code X199004)
2m Lead assembly RS232 (order code X199005)
Adaptor plug USB → PS2 (order code X199006)
0.5m Lead assembly buttons (order code X199012)

Whilst the information provided herein is to the best of our knowledge true and accurate, it is provided for guidance only. You are strongly advised to ensure that the information provided is up to date. This document does not constitute any part of a contract unless expressly agreed in writing. Use of Pretorian Technologies Ltd. products in life support systems is not permitted except with the express written approval of the Company.

Copyright in this document is vested in Pretorian Technologies Ltd. All rights reserved. No unauthorised copying, transmission or storage in retrieval systems except as permitted by relevant copyright law. All other trade names and trademarks mentioned herein are the property of their respective owners.