

PanelPro™ 38mm Quadrature Output Trackball

DESCRIPTION

The Pretorian Technologies Ltd. PanelPro™ range of Trackball products is a high-precision family of pointing devices which combines advanced features with extremely high build quality for the most demanding professional, industrial and military environments.

Each unit has the option of a self-adjusting seal around the ball which affords the unit an IP65/NEMA 4 rating whilst ensuring that the ball tracks smoothly and accurately under all operating conditions.

All units benefit from a robust, durable metal bezel. This is normally manufactured from black anodised aluminium. In public access and highly ruggedised applications where misuse is likely, a stainless steel ball may be fitted, together with a stainless steel bezel and shock-transmission plate.

All PanelPro units are optionally available with a translucent, colourless ball which may be backlit.

All units are shipped with a comprehensive Data Log which provides a hard-copy of the unit's quadrature phase angle and all other tests which are performed by in-house Automatic Test Equipment.



FEATURES

- Durable 38mm phenolic resin, polyester or surface-treated steel ball.
- IP65 (NEMA 4) and IP40 (NEMA 2) seal options.
- Public-access versions with stainless steel bezel and shock-transmission plate.
- Phase Quadrature output.
- Backlighting options

APPLICATIONS

- Medical equipment.
- Specialist keyboards.
- Industrial process control.
- Air traffic control/ marine/ radar equipment.
- Studio equipment.
- Emergency vehicle control centres.

CONNECTION DETAILS

Main connector

Connection to the unit is afforded by means of a latching JST connector:

- J1 is the output connector for Power, Quadrature outputs and Backlight inputs (10-way).

Pin	J1 Function
1	X1 output
2	X2 output
3	Y1 output
4	Y2 output
5	DRAIN
6	N.C.
7	+5V
8	BACKLIGHT1 (normally green)
9	BACKLIGHT2 (normally red)
10	0V

Table 4: Main connector details

Suitable lead assemblies are available from Pretorian Technologies Ltd.- please contact your local sales office.

Notes:

The connector is JST right-angled type-PH headers with 2mm pitch. Mating connectors are PH, CR or KR types.

BACKLIGHT1 and BACKLIGHT2 inputs may be connected to a voltage source up to 5V nominal. On-board resistors limit the current through the LEDs to a safe level.

The 0V connection on J4 must be common with the main 0V.

Please refer to AN0011 for further information.

MECHANICAL FEATURES

The PanelPro range of Trackballs benefits from a number of mechanical features which make the units more robust:

Ball Seal

The unit may optionally be fitted with a self-adjusting seal which maintains contact with the ball at all times and prevents ingress of liquids and foreign matter.

The profile of the seal has been carefully determined by Pretorian Technologies to optimize the sealing capabilities whilst minimising wear. A very low friction material is used to help minimise the drag.

When fitted, the seal affords the unit an IP65 (NEMA 4) rating whilst the ball is static. When the ball is revolving, the rating is reduced to IP54 (NEMA 3). Units not fitted with a seal have an IP40 (NEMA 2) rating.

Ball Skirt

This is a means for ensuring that any liquids or foreign matter which do enter the unit are kept away from the sensitive circuit board. The cavity in which the ball sits is effectively elongated such that any liquid which enters the unit runs down the inner walls and off the ball skirt, well away from the circuit board. This prevents 'leeching' of liquids between the circuit board and plastic body by capillary action, which can cause corrosion.

Ball Colour Options

The colour of the ball may be specified in the order code (see Page 7) to suit any application. Stainless steel balls give the unit added resilience to vandal attack as well as augmenting the overall appearance of the unit. Solid coloured balls (black, red and yellow) are manufactured from thermoset phenolic resin and translucent balls from polyester.

Public Access/Ruggedised Applications

For high usage, public-access applications or where the Trackball is likely to be subjected to extreme abuse- such as point of information (POI) terminals and internet kiosks- all units may be fitted with a solid stainless steel 440 grade ball, stainless steel ruggedised bezel and shock-transmission plate.

The shock-transmission plate fixes to the base of the Trackball using the standard fixing bosses. Consequently it does not require any extra panel holes or studs. It is manufactured from thick stainless steel and is designed to allow a minimum of clearance between the ball and the plate. A heavy blow to the ball causes the ball to contact the plate and so doing transmits the energy via the mounting studs to the panel on which the unit is mounted. This prevents the energy being transmitted to the shafts, bearings, and mouldings and causing damage.

The stainless steel bezel completely shrouds the sensitive ball seal to prevent damage from knife attack.

Face Gasket

All units are supplied with a closed-cell gasket which forms a liquid-tight seal between the customer's panel and the Trackball mouldings.

Packaging

All Pretorian 50mm Trackballs are supplied in anti-static bags within a re-usable, bio-degradable cardboard box with dimensions 50 x 90 x 100mm. These boxes have an upper cardboard insert to give added protection during shipping.

SPECIFICATIONS

Mechanical

Weight	105 grams (phenolic ball) 90 grams (polyester ball) 240 grams (steel ball, stainless steel bezel)
Ball dimensions	38.1mm ±0.05mm
Tracking force	50g nominal- any direction (tangential to ball)
Ball speed	250 rpm maximum
Seal material	PTFE with low friction fill
Ball material	Phenolic resin, polyester or stainless steel 440
Body material	PC/ABS
Bezel material	Black anodised aluminium or stainless 303
Shaft material	Stainless 303

Electrical

Supply voltage	5.0V dc ±10%
Resolution	150 pulses/ball revolution 600 counts/ball revolution
Supply current (quadrature)	5mA maximum
Supply current (with backlight)	100mA maximum
Backlight internal current limit resistors	56Ω nominal
Maximum backlight current per colour	50mA
Maximum voltage to BACKLIGHT1 and BACKLIGHT2	5.5V dc.
Minimum voltage to BACKLIGHT1 and BACKLIGHT2	-0.7V
Minimum output high voltage X1,X2, Y1, Y2	4.5V
Maximum output low voltage X1, X2, Y1, Y2	0.8V
MTBF (25°C Ground Benign)	240750 hours

Environmental

Storage temperature	-25°C to +85°C
Operating temperature	0°C to +70°C
Humidity	95% rh, non-condensing, maximum
Vibration	5G, sinusoidal, 2-5kHz (swept), any plane
Static ball load	1000N maximum
Shock ball load	10J maximum- single blow
Lifetime	10 million ball revolutions minimum

MOUNTING DETAILS

Note that an *IGES* model of this unit is available on the Pretorian Technologies website- www.pretorianuk.com. This model contains only the outer casing detail but is sufficient to allow the model to be incorporated into a 3D model of the target equipment to ensure correct fitting.

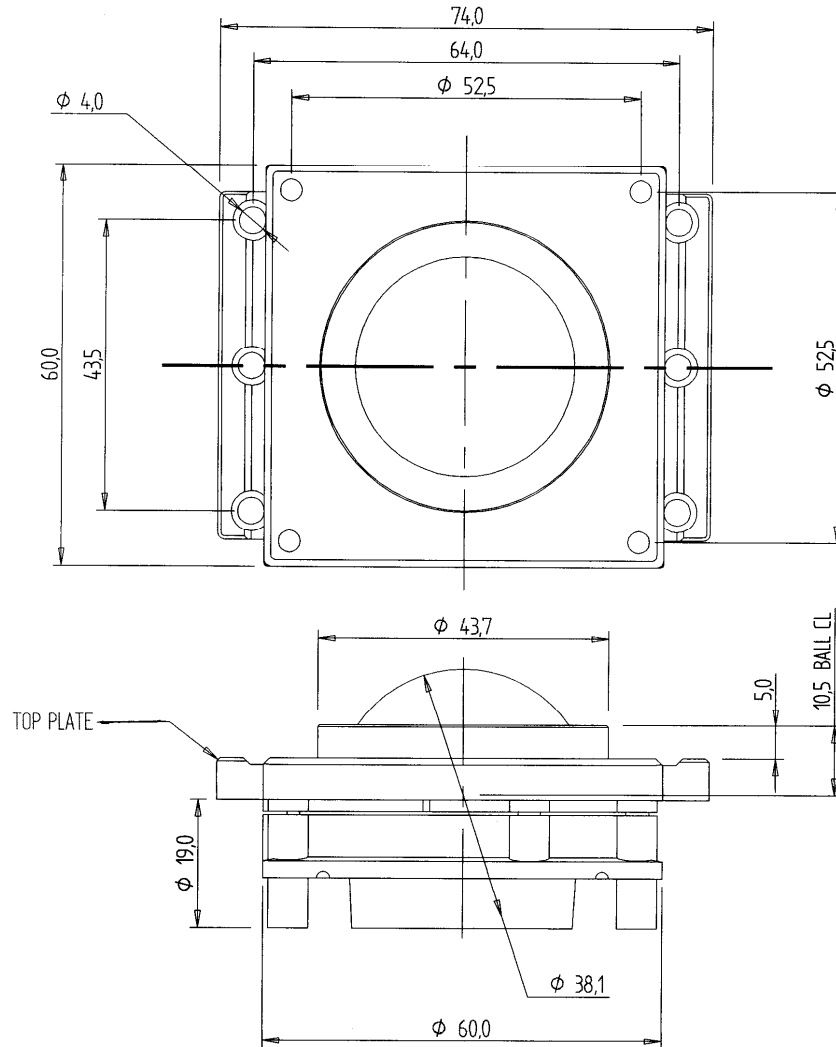

Note:

The PanelPro 38mm unit is also available without mounting 'wings', see T238XXX product range. Bezel height is dependent on choice of bezel type. Contact us for more details.

ORDERING INFORMATION

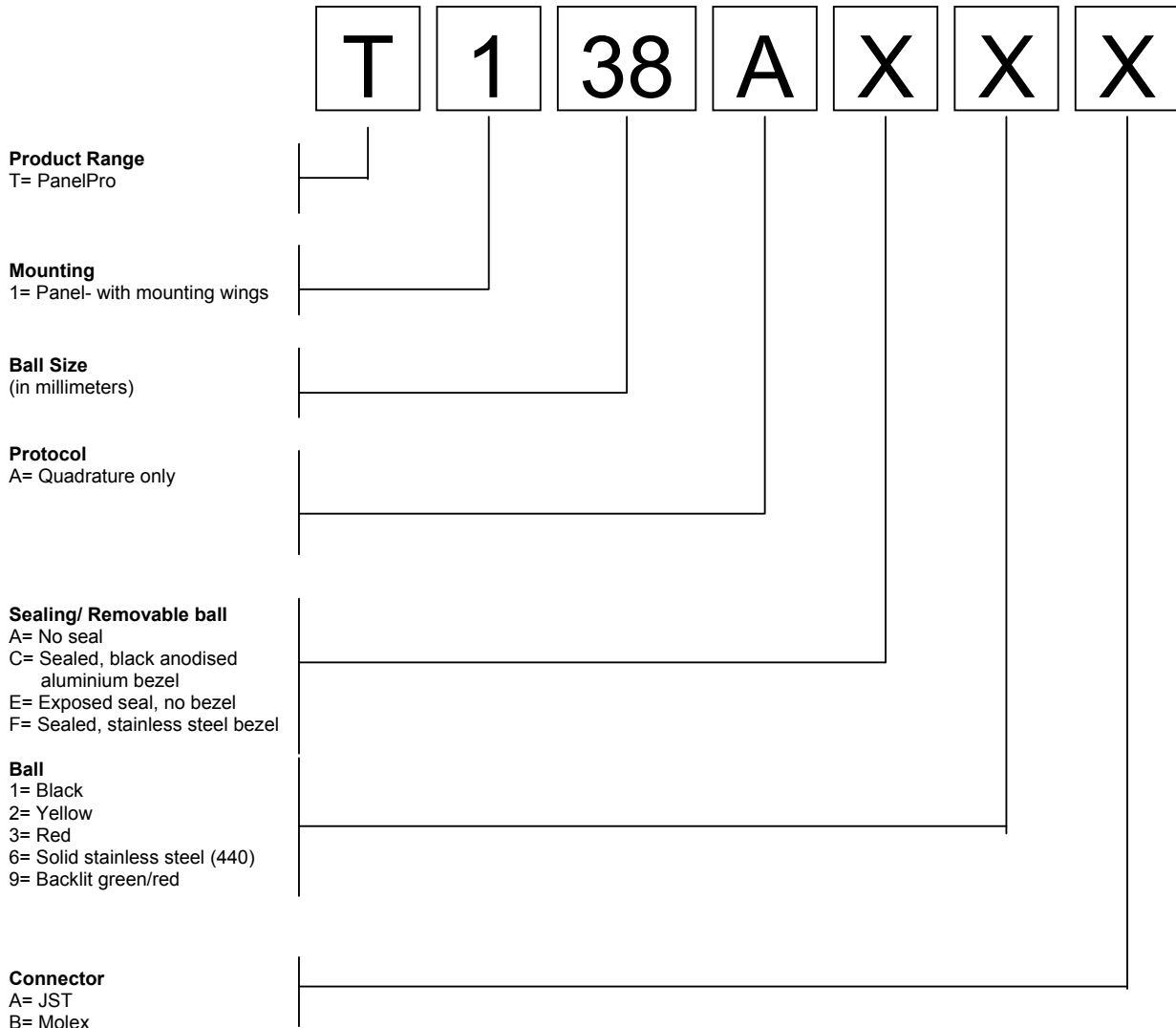

Examples:

The following are common order code examples:

- T138AA1A** 38mm, Phase Quadrature output, no seal, black ball.
- T138AE1A** 38mm, Phase Quadrature output, exposed IP65 seal, black ball.
- T138AF6A** 38mm, Phase Quadrature output, IP65 seal, stainless steel ball, stainless steel bezel.

OPTIONAL EXTRAS

0.5m lead assembly 10-way JST to unterminated wires (order code X199007)

Whilst the information provided herein is to the best of our knowledge true and accurate, it is provided for guidance only. You are strongly advised to ensure that the information provided is up to date. This document does not constitute any part of a contract unless expressly agreed in writing. Use of Pretorian Technologies Ltd. products in life support systems is not permitted except with the express written approval of the Company. Copyright in this document is vested in Pretorian Technologies Ltd. All rights reserved. No unauthorised copying, transmission or storage in retrieval systems except as permitted by relevant copyright law. All other trade names and trademarks mentioned herein are the property of their respective owners.