



## CX93040-1x CSPMxx Features

- ◆ Slave SPI Interface Modulations and protocols
  - ITU-T V.92: Quick Connect, Modem-on-Hold and PCM upstream
  - V.90/V.34/V.32bis/V.32
  - V.22bis/V.22/V.23/V.21
  - V.23 reverse, V.23 half-duplex
  - Bell 212A/Bell 103
  - V.29 FastPOS and V22 Fast Connect
  - SIA Protocol and Contact ID for alarm equipment
  - V.80 Synchronous Access Mode
  - V.17/V.29 Fax Class 1/1.0 and Fax Class 2
- ◆ V.44/V.42bis/MNP5 data compression
- ◆ V.42/MNP2-4 Error correction
- ◆ Call waiting (CW) detection for selected countries
- ◆ Hardware and software flow control and speed buffering
- ◆ Embedded and upgradable 63 country profiles
- ◆ Optional serial NVRAM interface for country profile storage and code upgrades
- ◆ Full-duplex 8-bit/16-bit PCM voice pass-through mode
- ◆ 28.224 MHz XTAL or clock input
- ◆ Worldwide operation
  - Complies to TBR21 and other country requirements
  - Type I Caller ID (CID) decoding
  - Type II Caller ID snooping
  - Call progress, blacklisting
  - Meets worldwide DC mask requirements
- ◆ Low power and voltage
  - Single +3.3 V supply
  - Low power consumption mode
  - +3.3 V I/O level
- ◆ Compact, robust board design
  - Reference design files provided for quick time-to-market
  - Reference design tested for PTT and TBR.21 approvals
  - Small, low-profile modem packages
  - Reference design supports 6KV isolation

## SmartDAA Features

- ◆ Extension pick-up detection
- ◆ Digital line protection
- ◆ Line reversal detection
- ◆ Remote hang-up detection
- ◆ Worldwide compliance
- ◆ CX20548 SmartDAA 4 LSD in a 16-pin QFN
- ◆ Worldwide support with a single design

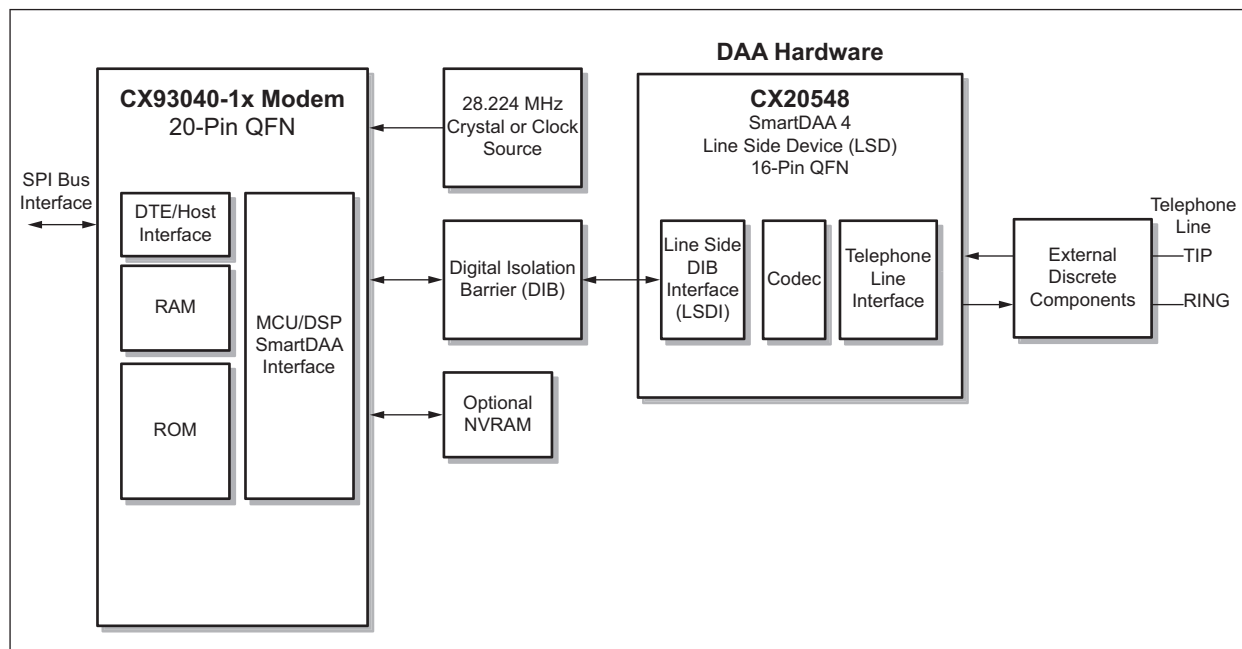

## Conexant Product Portfolio

Conexant's comprehensive product portfolio includes solutions for imaging, audio, video surveillance, and embedded modem applications

© 2011 Conexant Systems, Inc. All Rights Reserved. Conexant and the Conexant logo are registered trademarks of Conexant Systems, Inc. All other trademarks are owned by their respective owners. Although Conexant strives for accuracy in all its publications, this material may contain errors or omissions and is subject to change without notice. **THIS MATERIAL IS PROVIDED AS IS AND WITHOUT ANY EXPRESS OR IMPLIED WARRANTIES, INCLUDING MERCHANTABILITY, FITNESS FOR A PARTICULAR PURPOSE AND NON-INFRINGEMENT.** Conexant shall not be liable for any special, indirect, incidental or consequential damages as a result of its use.

**www.conexant.com**  
 General Information:  
 U.S. and Canada: (888) 855-4562  
 International: 1+ (949) 483-3000  
 Headquarters  
 4000 MacArthur Blvd.  
 Newport Beach, CA 92660

Doc# PBR-202792