



Features

Printer Support

- Up to 120 pages per minute (ppm) tandem color laser printing of 4-bit contone data
- USB 2.0 high-speed and 10/100 Ethernet printing supported
- Scalable support for both graphics device interface (GDI) and page description language (PDL)-based printing

Scanner Support

- Up to 30 images per minute (ipm) color scanning at 600 dpi
- Flatbed and automatic document feeder (ADF) scanners supported, including timing and motor control
- Charge-coupled device/contact image sensor (CCD/CIS) control
- Scan pre-processing supports gamma, shading, white-level and black-level corrections, 3xCIS data arrangement support

Copier Support

- Up to 30 copies per minute (cpm) ADF multi-page color copying at 600 dpi scan and print
- Tunable photo/text segmentation logic ensures best copy quality of mixed images
- Independent finite impulse response (FIR) filters, color space conversion tables and dither tables for photo and text

Fax Support

- Fax controller with complete protocol stack for leading Conexant fax modems

External Memory Support

- DDR2-533 supported: Up to 1 GB of system memory
- Field upgradeable using DIMM

Connectivity/Interfaces

- USB 2.0 high-speed device and hosts
- Synchronous serial bus configurable for: 1-bit, 4-bit or 8-bit high-speed MMC/SD/SDIO; 4-bit or 8-bit CE-ATA mode; SPI; 1-bit MS; TI SSI
- I²C
- UARTs
- Thin Film Transistor (TFT) or Super-twisted Nematic Display (STN) graphical LCD controller

Processor/CPU

- 32-bit, RISC microprocessor with Memory Management Unit (MMU) and vector floating point processor
- Compact 16-/32-bit instruction set, offering reduced code size and higher performance

Development Environment

- Conexant's Integrated Development Environment (IDE)
- C/C++ Compiler/Assembler/Linker
- PC Command Line Debugger/Profiler
- JTAG Emulator/ICE and Debugger

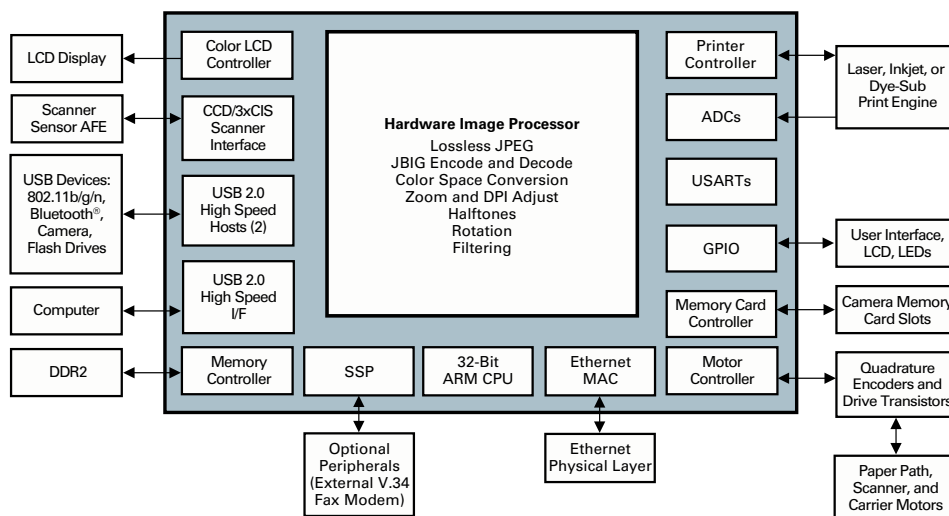

CX92235 Block Diagram

Conexant Product Portfolio

Conexant's comprehensive product portfolio includes solutions for imaging, audio, and video applications, and analog modems that enable cost-effective Internet access. The company's broadband access products include end-to-end solutions for xDSL networks, and PON solutions for fiber optic applications.

© 2008 Conexant Systems, Inc. All Rights Reserved. Conexant and the Conexant logo are registered trademarks of Conexant Systems, Inc. All other trademarks are owned by their respective owners. Although Conexant strives for accuracy in all its publications, this material may contain errors or omissions and is subject to change without notice. **THIS MATERIAL IS PROVIDED AS IS AND WITHOUT ANY EXPRESS OR IMPLIED WARRANTIES, INCLUDING MERCHANTABILITY, FITNESS FOR A PARTICULAR PURPOSE AND NON-INFRINGEMENT.** Conexant shall not be liable for any special, indirect, incidental or consequential damages as a result of its use.

www.conexant.com
General Information:
 U.S. and Canada: (888) 855-4562
 International: 1+ (949) 483-3000
Headquarters
 4000 MacArthur Blvd.
 Newport Beach, CA 92660
 Doc# PBR-202000

