



Additional Features

There are two variants of the CX25854 offered - one with the external DDR2 interface, and one without the interface. When equipped with DDR2, the CX25854 supports frame-interleaved video outputs, as well as a 2x2 CIF tiling mode, in which four CIF images are tiled into a single D1 stream.

The CX25854 contains 48 GPIO pins, which maximize flexibility and allow customization to a variety of applications and designs. I²C interfaces and the Maxim interface are supported via GPIOs.

The CX25854 includes programmable motion detection logic, which can trigger flags or PCIe interrupts when motion is detected on incoming analog video streams.

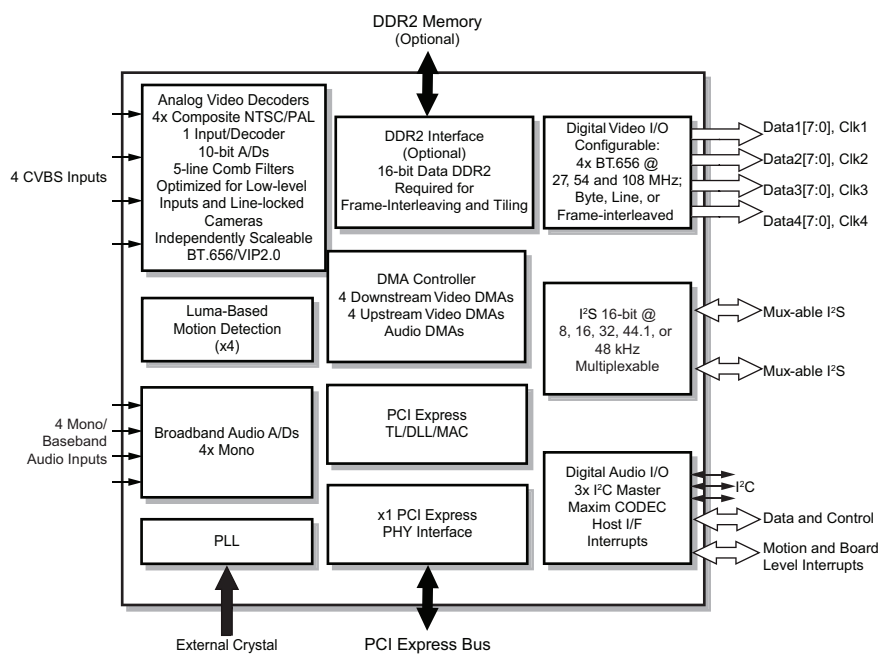

CX25854 Block Diagram

The CX25854-1x (contains DDR2 interface) is offered in a 23mm x 23mm, 288 pin fpBGA package.

The CX25854-2x (no DDR2 interface) is offered in a 14mm X 14mm, 233 pin fpBGA package.

Conexant Product Portfolio

Conexant's comprehensive product portfolio includes solutions for imaging, audio, video, and embedded-modem applications.

© 2013 Conexant Systems, Inc. All Rights Reserved. Conexant and the Conexant logo are registered trademarks of Conexant Systems, Inc. All other trademarks are owned by their respective owners. Although Conexant strives for accuracy in all its publications, this material may contain errors or omissions and is subject to change without notice. **THIS MATERIAL IS PROVIDED AS IS AND WITHOUT ANY EXPRESS OR IMPLIED WARRANTIES, INCLUDING MERCHANTABILITY, FITNESS FOR A PARTICULAR PURPOSE AND NON-INFRINGEMENT.** Conexant shall not be liable for any special, indirect, incidental or consequential damages as a result of its use.

www.conexant.com
General Information:
U.S. and Canada:
(888) 855-4562
International:
1+ (949) 483-3000
Headquarters
4000 MacArthur Blvd.
Newport Beach, CA 92660

Doc# PBR-203156

Distributor/Representative Information