

CX93610 Features

Operating Modes

- ◆ Visual verification of intruder via image sensor interface
- ◆ SXGA 1.3MP (1280x1024) and HD (1280x720) - B&W or Color @ up to 15 fps (512KB option only)
- ◆ D1 (720x480) and VGA (640x480) - B&W or Color @ up to 30 fps
- ◆ Up to 5MP (2592x1944) - B&W or Color, JPEG still captures (512KB option only)
- ◆ Resolution Scaling of ½ or ¼ (available for input resolutions of 1280x1024 or lower)
- ◆ 4:2:2 to 4:2:0 Sub-Sampling Conversion (available for input resolutions of 1280x1024 or lower)
- ◆ JPEG & MJPEG Image Compression (ISO/IEC 10918-1/2)
- ◆ Programmable Difference Threshold Encoded JPEG Mode (DIFT)
- ◆ Differential Encoded JPEG Mode (DIFF)
- ◆ Programmable DCT tables for ultimate flexibility in compression and image quality (2 pre-defined tables)
- ◆ Privacy Mode - blurs out image details
- ◆ Frame by Frame Motion Detection with programmable thresholds
- ◆ Light Detection through luminance measurements with auto IR LED control
- ◆ Continuous streaming and variable image modes

- ◆ 512KB/256KB frame buffer for compressed images (no external memory) with programmable audio buffer allocation
- ◆ Interface to external mP though SPI, UART, or I²C
- ◆ Variable IR illumination control port
- ◆ A/D for Photocell sensor, Battery voltage monitor, and microphone inputs
- ◆ Sleep mode - SoC off except frame buffer in retention mode
- ◆ Integrated DC-DC converter for reduced power consumption

Interfaces

- ◆ Sensor i/f
 - 8-b 4:2:2 YCbCr with BT-656 embedded timing codes or frame/line sync support up to 54 MHz, progressive mode
 - Resolutions: 5MP (2592x1944), 1.3MP SXGA (1280x1024), (VGA (640x480) & QVGA (320x240)
 - 54 MHz or 48 MHz clk output with divide-by-two option for 27 MHz or 24 MHz output
 - Crystal/Clock input allowing 54 MHz, 48 MHz, 27 MHz, or 24 MHz. Supports fundamental and 3rd overtone crystals
 - 2/3 wire control i/f: I²C Master port or SCCB

- ◆ 4-wire I²C/SPI/UART slave port to external mP
- ◆ 8 GPIO (5 dedicated pins, 3 shared pins)
- ◆ IR illumination with variable DAC control
- ◆ Microphone input, mic boost 0-36 dB in 6 dB steps, 2- and 4- bit ADPCM
- ◆ DC measurement battery monitor
- ◆ Photocell sensor input - analog or I²C (shared with GPIO)
- ◆ Support for battery operation: 3.6 V to 1.8 V

56-pin eMLF/QFN

- ◆ -10 °C to +85 °C ambient,
- ◆ +100 °C junction
- ◆ Full industrial temperature version available (-40 °C to +85 °C)
- ◆ TBD mA in operational mode
- ◆ 10 nA in sleep mode

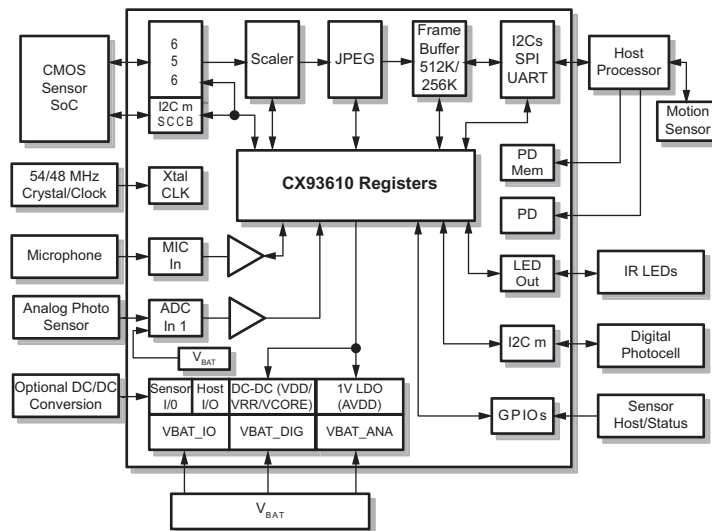

CX93610 Functional Block Diagram

© 2011 Conexant Systems, Inc. All Rights Reserved. Conexant and the Conexant logo are registered trademarks of Conexant Systems, Inc. All other trademarks are owned by their respective owners. Although Conexant strives for accuracy in all its publications, this material may contain errors or omissions and is subject to change without notice. **THIS MATERIAL IS PROVIDED AS IS AND WITHOUT ANY EXPRESS OR IMPLIED WARRANTIES, INCLUDING MERCHANTABILITY, FITNESS FOR A PARTICULAR PURPOSE AND NON-INFRINGEMENT.** Conexant shall not be liable for any special, indirect, incidental or consequential damages as a result of its use.

www.conexant.com

General Information:
 U.S. and Canada:
 (888) 855-4562
 International:
 1+ (949) 483-3000
 Headquarters
 4000 MacArthur Blvd.
 Newport Beach, CA 92660

Doc# PBR-202885

Distributor/Representative Information