



CX20745 Features CODEC

- Stereo 8/16/24-bit DAC supports sample rates capable of 8, 8.018, 11.025, 12, 16, 16.0364, 22.05, 24, 32, 44.1, 48, 88.2, and 96 kHz, depending on the master clock
 - 98 dB Dynamic Range
 - -85 dB THD
- Stereo 8/16/24-bit ADC supports sample rates capable of 8, 8.018, 11.025, 12, 16, 16.0364, 22.05, 24, 32, 44.1, 48, 88.2, and 96 kHz, depending on the master clock
- Supports master clock of 24.576 MHz and 22.5792 MHz
- Data interface: I²S that can be converted to PCM, I²S/PCM are slave only
- Control Interface: I²C slave only
- Audio ports:
 - Stereo analog input port supporting up to one single-ended stereo microphone, one differential mono microphone, one single-ended stereo line-in, or one differential mono line-in

- 4-conductor OMTP headset set jack compliant with integrated in-line command sensing. Mic bias sensing capability for external headset control. Supports sense and switching between MIC and GND pins
- Stereo class-D amplifier
- Stereo capless headphone port
- Single-ended analog line output (stereo)
- Digital microphone input (stereo)
- Class-D amplifier with the following modes of operation:
 - Up to 2 W per channel into 4Ω with 5 V supply
 - Up to 1 W per channel into 4Ω with 3.3 V supply
 - Spread Spectrum for EMI protection on the class-D amplifier
- Line-In loopback mode, where the input signal will loop back to the DAC for playback with EQ
- PopShield active anti-pop circuit
- Device can operate in 3.3 V only mode
- Integrated LDO converting 5 V to 3.3 V, and

3.3 V to 1.8 V

- PDM digital MIC interface supporting clock frequency of 3.072 MHz and 1.536 MHz
- Supports industrial temperatures of -40~85C
- Jack sense supporting up to four jacks
- Codec provides independent gain and mute control for both DAC and ADC
- Four General purpose GPIOs
 - GPIO1 and GPIO2 can be configured for “Infinity Volume Control” using a rotary encoder

DSP

- Digital parametric equalizer (5 bands/channel)
- Dynamic range control including compressor and limiter
- Microphone automatic gain control

Power Management

- Idle Mode: 2.2 mA with 10 ms fast resume
- Sleep Mode: 0.5 mA (digital supply only) with 200 ms resume

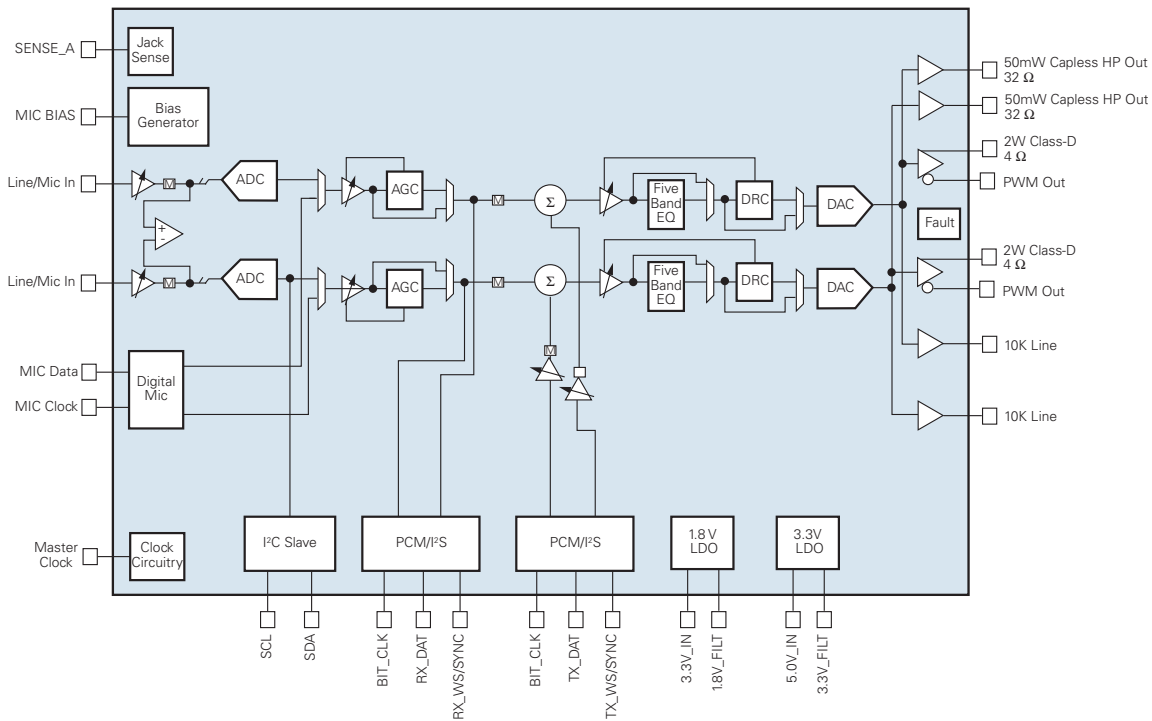

CX20745 System Block Diagram
The CX20745 is offered in a 48-pin QFN package

Conexant Product Portfolio

Conexant’s comprehensive product portfolio includes solutions for imaging, audio, video surveillance, and embedded modem applications.

© 2010 Conexant Systems, Inc. All Rights Reserved. Conexant and the Conexant logo are registered trademarks of Conexant Systems, Inc. All other trademarks are owned by their respective owners. Although Conexant strives for accuracy in all its publications, this material may contain errors or omissions and is subject to change without notice. **THIS MATERIAL IS PROVIDED AS IS AND WITHOUT ANY EXPRESS OR IMPLIED WARRANTIES, INCLUDING MERCHANTABILITY, FITNESS FOR A PARTICULAR PURPOSE AND NON-INFRINGEMENT.** Conexant shall not be liable for any special, indirect, incidental or consequential damages as a result of its use.

www.conexant.com
General Information:
 U.S. and Canada: (888) 855-4562
 International: 1+ (949) 483-3000
Headquarters
 4000 MacArthur Blvd.
 Newport Beach, CA 92660
 Doc# PBR-202653

