



CX20706 Features

CODEC

- Compliant Microsoft Office Communicator peripheral requirement
- Pass TIA-920 test requirement
- USB 2.0 Compliant Audio Class interface
- UART interface for external MCU
- Eight GPIO pins
- 2.5 W BTL Mono Class-D speaker amplifier
- Single-ended or differential stereo analog audio input
- Two microphones interfaces with on-chip bias supply
- Integrated 50 mW headphone driver with jack sense
- Single-ended or differential line out
- 24-bit DAC/ADC, SNR 102 dB, THD - 92 dB at 48 kHz 3.3 V
- Audio sample rate: 8, 11.025, 12, 16, 22.05, 24, 32, 44.1, 48, 64, 88.2, 96 kHz
- 90 dB dynamic range with 0.01percent THD+N at 4 Ω load
- Spread Spectrum for filter-less, low EMI output
- 10-bit ADC multiplexed to support analog volume potentiometer and DC level detection

- Flexible power management
- Variable master clock rates

DSP

- Subband acoustic echo suppression and cancellation
- Stereo beam-forming
- Noise reduction for inbound speech (far end) and outbound speech (near end)
- Dynamic loudness adaptor
- Mic auto gain control
- Digital parametric equalizer (10 bands/channel)
- Dynamic range compression

SPoC Configuration Toolbox

- Fast configuration tool via USB-to-I²C from PC
- Device configuration and DSP parameter adjustment
- Output log for convenient MCU programming

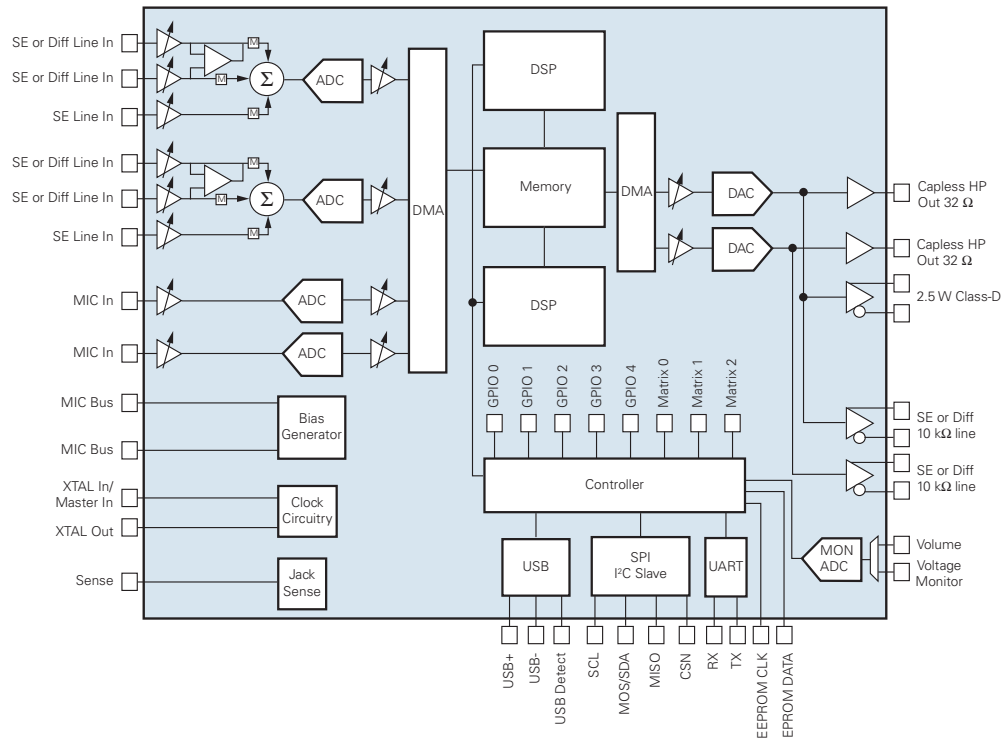

CX20706 Interface Diagram

The CX20706 is offered in a 76-pin QFN package

Conexant Product Portfolio

Conexant's comprehensive product portfolio includes solutions for imaging, audio, embedded modem and video surveillance applications.

© 2009 Conexant Systems, Inc. All Rights Reserved. Conexant and the Conexant logo are registered trademarks of Conexant Systems, Inc. All other trademarks are owned by their respective owners. Although Conexant strives for accuracy in all its publications, this material may contain errors or omissions and is subject to change without notice. **THIS MATERIAL IS PROVIDED AS IS AND WITHOUT ANY EXPRESS OR IMPLIED WARRANTIES, INCLUDING MERCHANTABILITY, FITNESS FOR A PARTICULAR PURPOSE AND NON-INFRINGEMENT.** Conexant shall not be liable for any special, indirect, incidental or consequential damages as a result of its use.

www.conexant.com
General Information:
 U.S. and Canada: (888) 855-4562
 International: 1+ (949) 483-3000
 Headquarters
 4000 MacArthur Blvd.
 Newport Beach, CA 92660
 Doc# PBR-202454

