



Speakers-on-a-Chip with On-chip Voice/Audio DSP, Integrated I²S/I²C Codec, and Mono Class-D Amplifier

CX20704

Conexant's portfolio includes a comprehensive suite of semiconductor solutions for communications and consumer applications.

The CX20704 is one of Conexant's Speakers-on-a-Chip (SPoC) embedded audio solutions for convergence audio entertainment and voice communication applications. The SPoC features a proprietary on-chip Digital Signal Processor (DSP), Codec, Mono Class-D Amplifier, I²S and I²C interfaces, high performance 24-bit DAC's and ADC's, a range of digital and analog input/output channel selections for flexible routing and mixing, and a stereo capless headphone driver in a cost-effective single-chip package. The solution features a suite of turnkey audio and voice enhancement algorithms designed for applications such as Portable Navigation Devices, Portable Media Players, Multimedia IP phones, and Mobile Internet Devices. This product is part of the CX2070x SPoC family, which includes CX20702, CX20703, CX20705, CX20706, CX20707 and CX20709.

The device features multiple high performance 24-bit DACs for stereo speaker output, multiple 24-bit high performance ADCs supporting mono microphone and one stereo line input, capless headphone output, support for bi-directional I²S, PCM, S/PDIF-out with independent sampling rates, and a range of digital and analog input/output channel selections for flexible routing and mixing. Different audio sampling rates ranging from 8 kHz to 96 kHz are generated directly from the master clock without the need for external PLL. The power-efficient mono Class-D amplifier drives a maximum of 2.5 Watt (average) from the integrated amplifier. The device can be controlled and configured by both read and write capability through I²C and Serial Peripheral Interface (SPI).

The on-chip Digital Signal Processor (DSP) runs a suite of innovative Conexant proprietary voice processing algorithms and audio post processing effects that dramatically improves sound quality and frees-up processing power for other applications without compromising on cost and future firmware scalability. Key audio innovations include Subband Acoustic Echo Suppression and Cancellation, Noise Reduction, Dynamic Loudness Adapter, Mic Auto Gain Control, Digital Equalizer, Dynamic Range Compression, and 3D effects. The embedded SPoC Configuration Toolbox allows for fast configuration and performance optimization.

The CX20704 turnkey solution eliminates the need for a multiple-chip reference design, making it easy and economical for manufacturers to design products for high quality audio and voice applications. A complete evaluation kit with reference board and all the necessary technical documents and software is available.

The SoC is packaged in an environmentally-friendly, RoHS/Green-compliant 76-pin QFN (Quad Flat No leads) package.

Applications

- Portable Navigation Device
- Portable Media Player
- Multimedia IP phone
- Mobile Internet Device



Distinguishing Features

- 24-bit DAC/ADC, SNR 102 dB, THD - 92 dB at 48 kHz 3.3 V
- Programmable on-chip proprietary DSP
 - Subband acoustic echo suppression and cancellation
 - Noise reduction
 - Dynamic loudness adaptor
 - Mic auto gain control
 - Digital equalizer (10 bands/channel)
 - Dynamic range compression
 - 3D Expander (Phantom mode and Immersion mode)
- 5-wire digital audio I/O (I²S/PCM/SPDIF-out), supporting full duplex independent sampling rates
- One 2-wire I²C or 4-wire SPI slave interface for external MCU
- 2.5 W BTL mono Class-D speaker amplifier
- One microphone interface with on-chip bias supply
- Flexible power management
- Audio sample rate: 8, 11.025, 12, 16, 22.05, 24, 32, 44.1, 48, 64, 88.2, 96 kHz

Part Number CX20704

Description Speakers-on-a-Chip with On-chip Voice/Audio DSP, Integrated I²S/ I²C Codec, and Mono Class-D Amplifier



CX20704 Features

CODEC

- 5-wire digital audio I/O (I2S/PCM/SPDIF), supporting full duplex independent sampling rates
- One 2-wire I²C or 4-wire SPI slave interface for external MCU
- Eight GPIO pins
- 2.5 W mono Class-D speaker amplifier
- Single-ended or differential stereo analog audio input
- One microphone interface with on-chip bias supply
- Integrated 50 mW headphone driver with jack sense
- Single-ended or differential line out
- 24-bit DAC/four ADC, SNR 102 dB, THD - 92 dB at 48 kHz 3.3 V
- Audio sample rate: 8, 11.025, 12, 16, 22.05, 24, 32, 44.1, 48, 64, 88.2, 96 kHz
- 90 dB dynamic range with 0.01percent THD+N at 4 Ω load
- Spread Spectrum for filter-less, low EMI output
- 10-bit ADC multiplexed to support analog volume potentiometer and DC level detection

- Flexible power management
- Variable master clock rates

DSP

- Subband acoustic echo suppression and cancellation
- Noise reduction
- Dynamic loudness adaptor
- Mic auto gain control
- Digital parametric equalizer (10 bands/channel)
- Dynamic range compression
- 3D Expander (Phantom mode and Immersion mode)

SPoC Configuration Toolbox

- Fast configuration tool via USB-to-I²C from PC
- Device configuration and DSP parameter adjustment
- Output log for convenient MCU programming

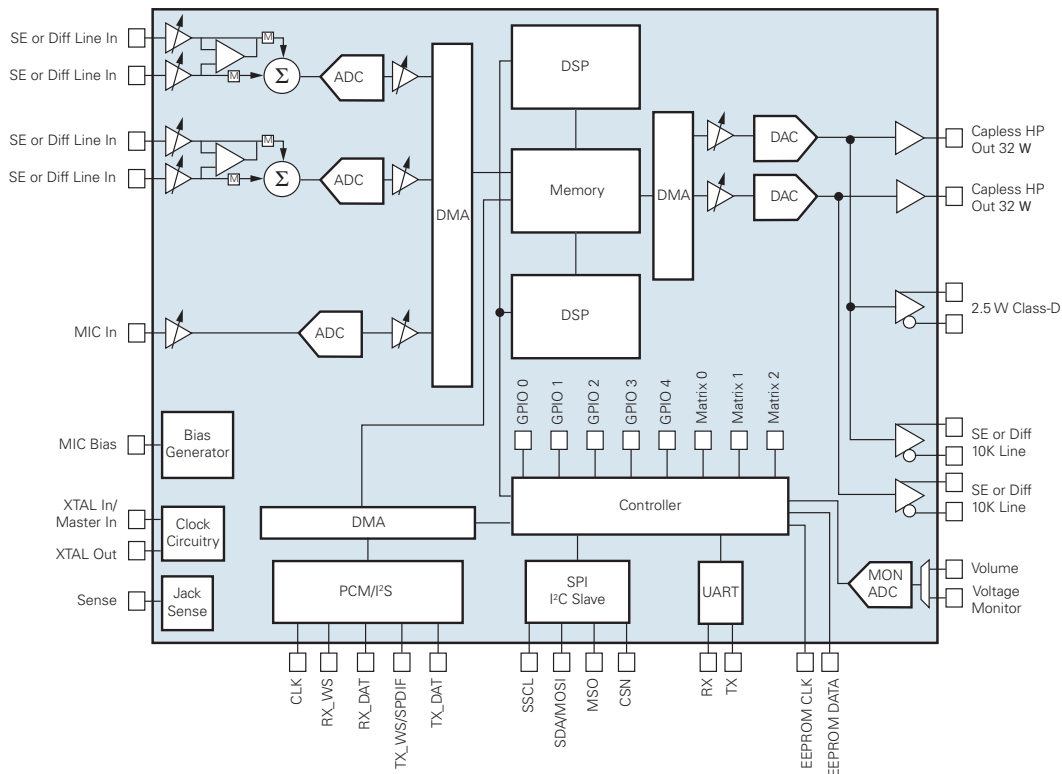

CX20704 Interface Diagram

The CX20704 is offered in a 76-pin QFN package

Conexant Product Portfolio

Conexant's comprehensive product portfolio includes solutions for imaging, audio, embedded modem and video surveillance applications.

© 2009 Conexant Systems, Inc. All Rights Reserved. Conexant and the Conexant logo are registered trademarks of Conexant Systems, Inc. All other trademarks are owned by their respective owners. Although Conexant strives for accuracy in all its publications, this material may contain errors or omissions and is subject to change without notice. **THIS MATERIAL IS PROVIDED AS IS AND WITHOUT ANY EXPRESS OR IMPLIED WARRANTIES, INCLUDING MERCHANTABILITY, FITNESS FOR A PARTICULAR PURPOSE AND NON-INFRINGEMENT.** Conexant shall not be liable for any special, indirect, incidental or consequential damages as a result of its use.

www.conexant.com
General Information:
 U.S. and Canada: (888) 855-4562
 International: 1+ (949) 483-3000
 Headquarters
 4000 MacArthur Blvd.
 Newport Beach, CA 92660
 Doc# PBR-202453

