



## DUAL PRECISION CMOS VOLTAGE COMPARATOR WITH PUSH-PULL DRIVER

### GENERAL DESCRIPTION

The ALD2332A/ALD2332B/ALD2332 is a monolithic high performance dual precision voltage comparator built with advanced silicon gate EPAD<sup>®</sup> CMOS technology intended for high precision analog applications. The ALD2332A/ALD2332B/ALD2332 offers ultra-low input offset voltages and currents at its input pre-amplifier, precision voltage comparator and high-current output driver integrated on-chip, in one industry standard pinout 8 Lead PDIP or SOIC package. Primary features include: very high typical input impedance of  $10^{12}\Omega$ ; low input bias current of 10pA; fast response time of 520ns with only 10mV input step signal; very low power dissipation of 175 $\mu$ A per comparator; single (+5V) or dual ( $\pm$ 5V) power supply operation; and 50mA push-pull output drivers.

The input voltage range includes ground, which makes these comparators ideal for single supply low level signal detection with high source impedance. The outputs can source and sink current allowing for application flexibility. They can be used in either wired-OR connection without pull-up resistor or push-pull configuration. ALD2332A/ALD2332B/ALD2332 can also be used in wired-OR connection with other open drain circuits such as the ALD2331/ALD2303 voltage comparators.

The ALD2332A/ALD2332B/ALD2332 voltage comparators are ideal for a great variety of precision analog voltage comparator applications, especially in low level signal detection circuits which require low standby power and high output current.

### FEATURES

- Guaranteed to drive 200 $\Omega$  loads
- Fanout of 30LS TTL loads
- Low supply current of 175 $\mu$ A each comparator
- Pinout of LM193 type industry standard voltage comparators
- Extremely low input bias currents -- typically 10pA
- Virtually eliminates source impedance effects
- Low operating supply voltage of 4V to 10V
- Single (+5V) and dual supply  $\pm$ 5V operation
- High speed for both large and small signals -- 180ns for TTL inputs and 400ns for 20mV overdrive
- CMOS, NMOS and TTL compatible
- Push-pull outputs-current sourcing/ sinking
- High output sinking current -- typically 50mA
- Low supply current spikes
- High gain -- 100V/mV

### ORDERING INFORMATION ("L" suffix for lead free version)

Operating Temperature Range *	
0°C to +70°C	0°C to +70°C
8-Pin Small Outline Package (SOIC)	8-Pin Plastic Dip Package
ALD2332ASAL	ALD2332APAL
ALD2332BSAL	ALD2332BPAL
ALD2332SAL	ALD2332PAL

\* Contact factory for leaded (non-RoHS) or high temperature versions.

### APPLICATIONS

- MOSFET driver
- High source impedance voltage comparison circuits
- Multiple limit window comparator
- Power supply voltage monitor
- Photo-detector sensor circuit
- High speed LED driver
- Oscillators
- Battery operated instruments
- Remote signal detection
- Multiple relay drivers

### BENEFITS

- Simple precision reference voltage setting
- On-chip input pre-amplifier and output buffers
- Precision voltage comparison without pre-amplifier
- Eliminate need for second power supply
- Eliminate pull-up resistor

### PIN CONFIGURATION

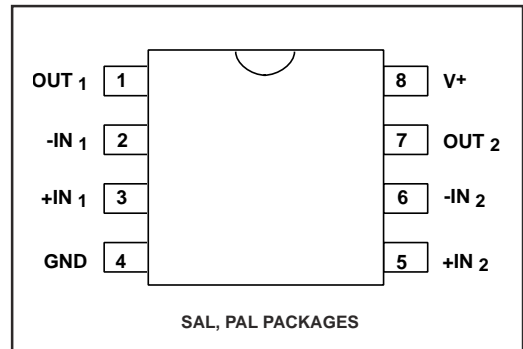

### BLOCK DIAGRAM

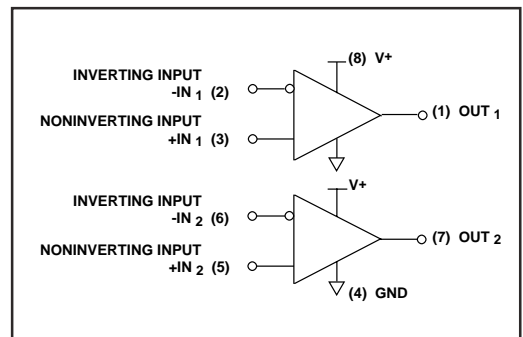

## ABSOLUTE MAXIMUM RATINGS

Supply voltage, V<sup>+</sup> \_\_\_\_\_ +10.6V  
 Differential input voltage range \_\_\_\_\_ -0.3V to V<sup>+</sup> +0.3V  
 Power dissipation \_\_\_\_\_ 600 mW  
 Operating temperature range PAL, SAL packages \_\_\_\_\_ 0°C to +70°C  
 Storage temperature range \_\_\_\_\_ -65°C to +150°C  
 Lead temperature, 10 seconds \_\_\_\_\_ +260°C

## OPERATING ELECTRICAL CHARACTERISTICS

T<sub>A</sub> = 25°C V<sup>+</sup> = +5V unless otherwise specified

Parameter	Symbol	2332A			2332B			2332			Unit	Test Conditions
		Min	Typ	Max	Min	Typ	Max	Min	Typ	Max		
Supply Voltage	V <sub>S</sub> V <sub>+</sub>	±2 4		±5 10	±2 4		±5 10	±2 4		±5 10	V V	Dual Supply Single Supply
Supply Current	I <sub>S</sub>		350	500		350	500		350	500	µA	No Load Two Comparators
Voltage Gain	A <sub>VD</sub>	50	150		50	150		50	150		V/mV	R <sub>LOAD</sub> ≥ 15K
Input Offset Voltage	V <sub>OS</sub>		0.02	0.5		0.5	1.0		1.0	2.0	mV	R <sub>LOAD</sub> ≥ 1.5KΩ
Input Offset Current <sup>1</sup>	I <sub>OS</sub>		0.01	20		0.01	20		0.01	20	pA	
Input Bias Current <sup>1</sup>	I <sub>B</sub>		0.01	20		0.01	20		0.01	20	pA	
Common Mode Input Voltage Range <sup>2</sup>	V <sub>ICR</sub>	-0.3		V <sup>+</sup> -1.5	-0.3		V <sup>+</sup> -1.5	-0.3		V <sup>+</sup> -1.5	V	
Low Level Sink Output Voltage	V <sub>OL</sub>		0.15	0.4		0.15	0.4		0.15	0.4	V	I <sub>SINK</sub> = 12mA V <sub>INPUT</sub> = 1V Differential
Low Level Sink Output Current	I <sub>OL</sub>	24	50		24	50		24	50		mA	V <sub>OL</sub> = 1.0 V SINK OUTPUT ON
High Level Source Output Voltage	V <sub>OH</sub>	3.5	4.5		3.5	4.5		3.5	4.5		V	I <sub>SOURCE</sub> = -2mA SOURCE OUTPUT ON
Response Time <sup>2</sup>	t <sub>RP</sub>		1.1			1.1			1.1		µs	R <sub>L</sub> = 5.1KΩ, C <sub>L</sub> = 15pF 5mV Input Step/ 0mV Overdrive
	t <sub>RP</sub>		2.4			2.4			2.4		µs	R <sub>L</sub> = 5.1KΩ, C <sub>L</sub> = 15pF 1mV Input Step/ 0mV Overdrive
	t <sub>RP</sub>		400			400			400		ns	R <sub>L</sub> = 5.1KΩ, C <sub>L</sub> = 15pF 100mV Input Step/ 20mV Overdrive
	t <sub>RP</sub>		180			180			180		ns	R <sub>L</sub> = 5.1KΩ, C <sub>L</sub> = 15pF TTL-Level Input Step
Common Mode Rejection Ratio	CMRR		80			80			80		dB	V <sub>INPUT</sub> = 0V to 2.5V
Power Supply Rejection Ratio	PSRR		75			75			75		dB	V <sup>+</sup> = 4V to 5V

Notes: <sup>1</sup> Consists of junction leakage currents  
<sup>2</sup> Sample test parameter

# TYPICAL PERFORMANCE CHARACTERISTICS

### TRANSFER FUNCTION

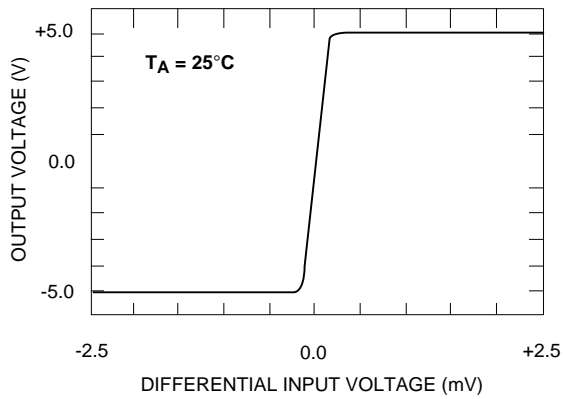

### COMMON - MODE VOLTAGE REFERRED TO SUPPLY VOLTAGE

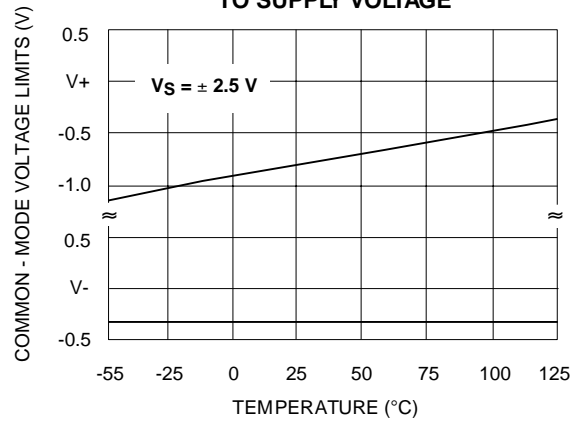

### TOTAL SUPPLY CURRENT vs. TOTAL SUPPLY VOLTAGE

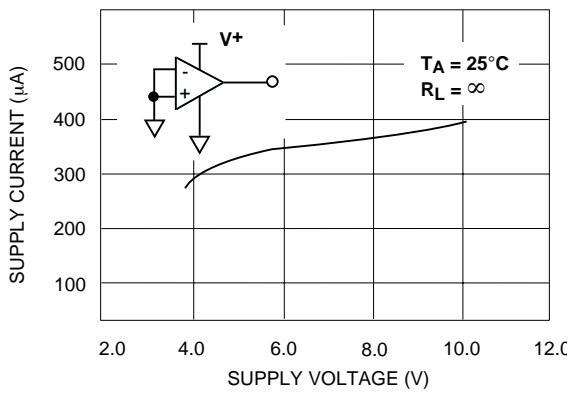

### SUPPLY CURRENT vs. TEMPERATURE

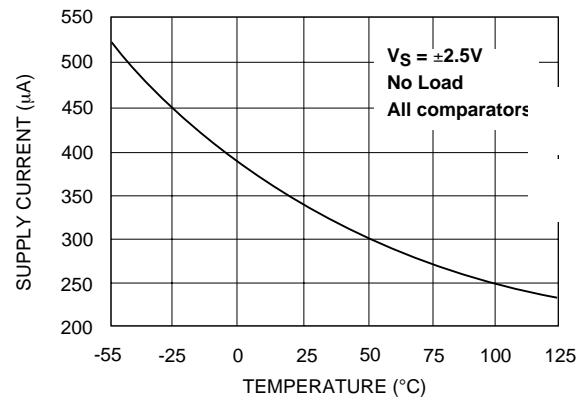

### NORMALIZED INPUT OFFSET VOLTAGE vs. TEMPERATURE

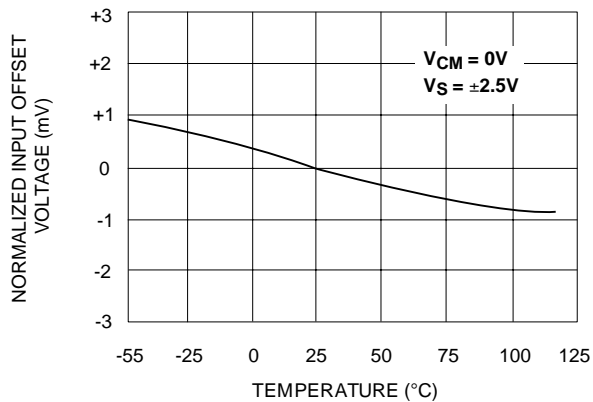

### OUTPUT HIGH VOLTAGE vs. SUPPLY VOLTAGE

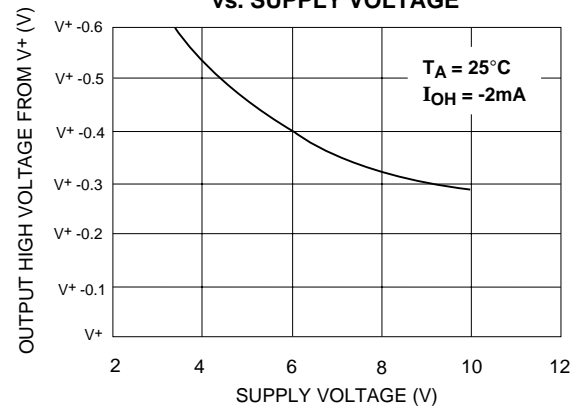

## TYPICAL PERFORMANCE CHARACTERISTICS (cont'd)

**OUTPUT LOW VOLTAGE vs. SUPPLY VOLTAGE**

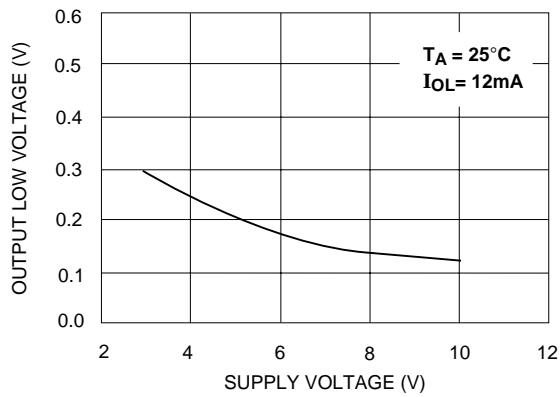

**INPUT BIAS CURRENT vs. TEMPERATURE**

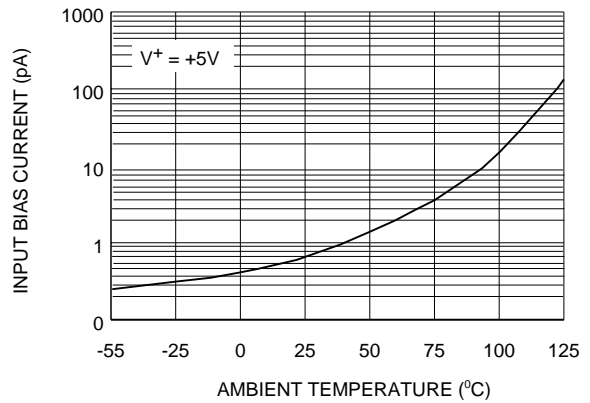

**LOW LEVEL OUTPUT VOLTAGE vs. TEMPERATURE**

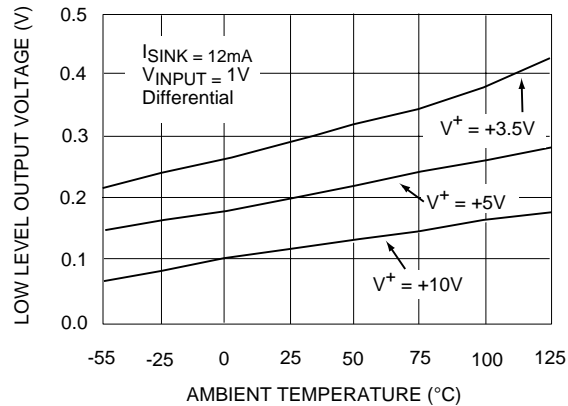

**SATURATION VOLTAGE vs. SINK CURRENT**

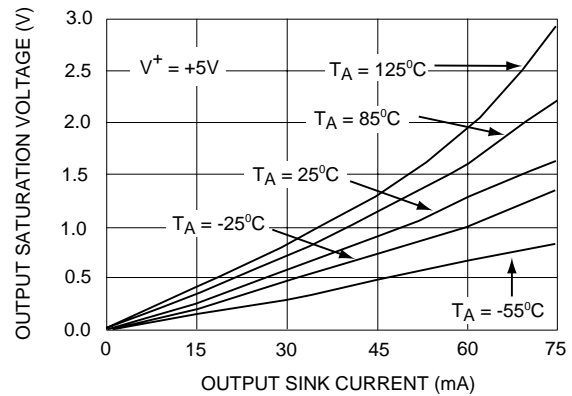

**HIGH LEVEL OUTPUT VOLTAGE vs. TEMPERATURE**

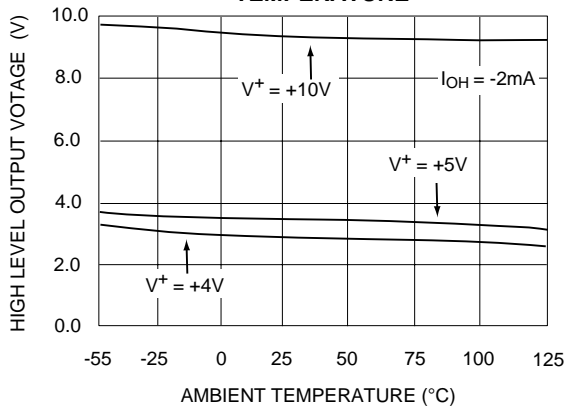

**INPUT OFFSET VOLTAGE vs. TEMPERATURE**

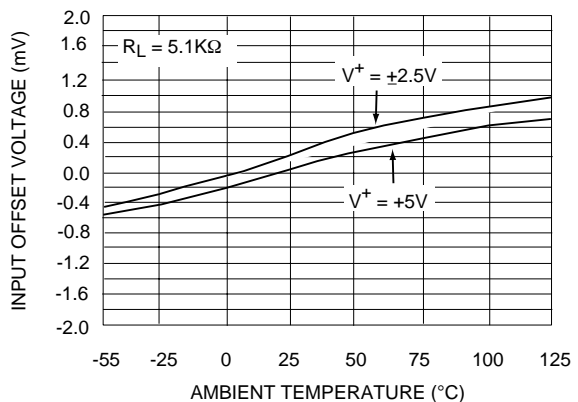

## TYPICAL PERFORMANCE CHARACTERISTICS (cont'd)

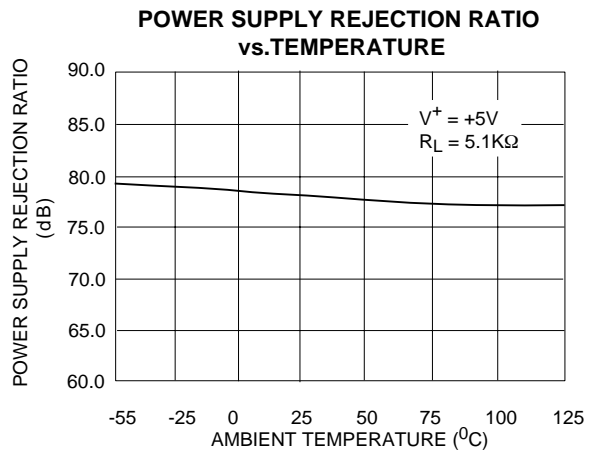
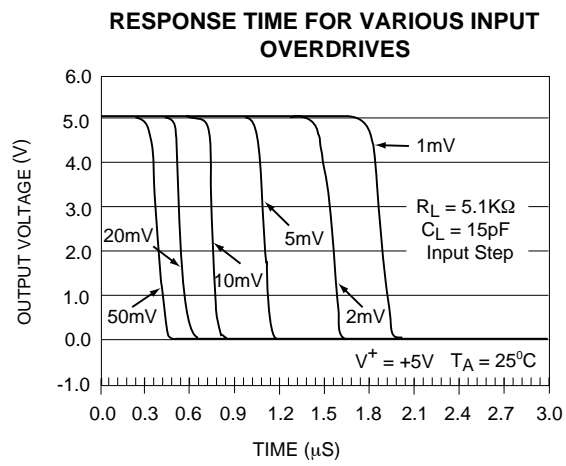
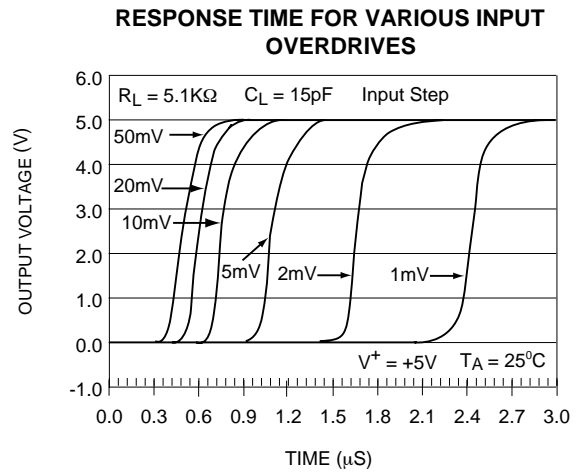
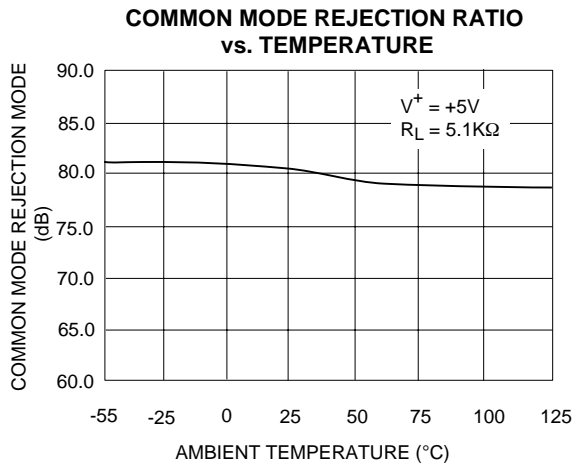

## TYPICAL APPLICATIONS

**PRECISION SINGLE SUPPLY VOLTAGE  
COMPARATOR WITH DIRECT RELAY DRIVER**

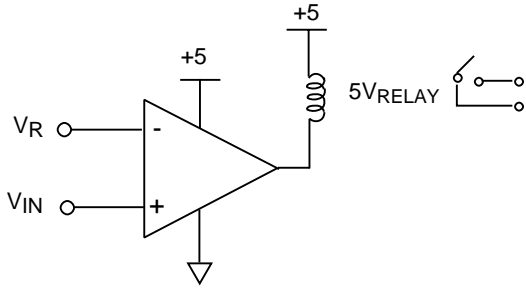

**PRECISION SINGLE SUPPLY VOLTAGE  
COMPARATOR WITH DIRECT RELAY DRIVER**

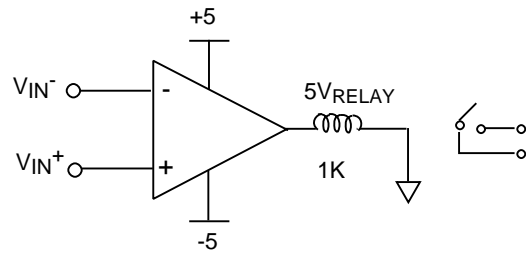

**ZERO CROSSING DETECTOR**

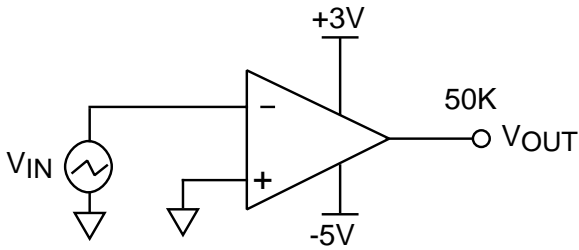

**MULTIPLE RELAY DRIVE**

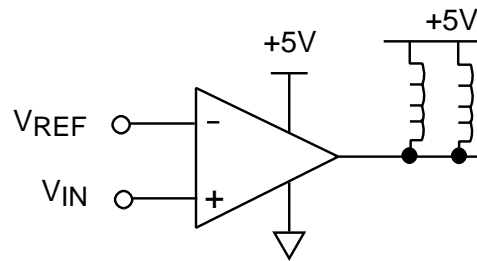

**DOUBLE DUAL LIMIT WINDOW COMPARATOR**

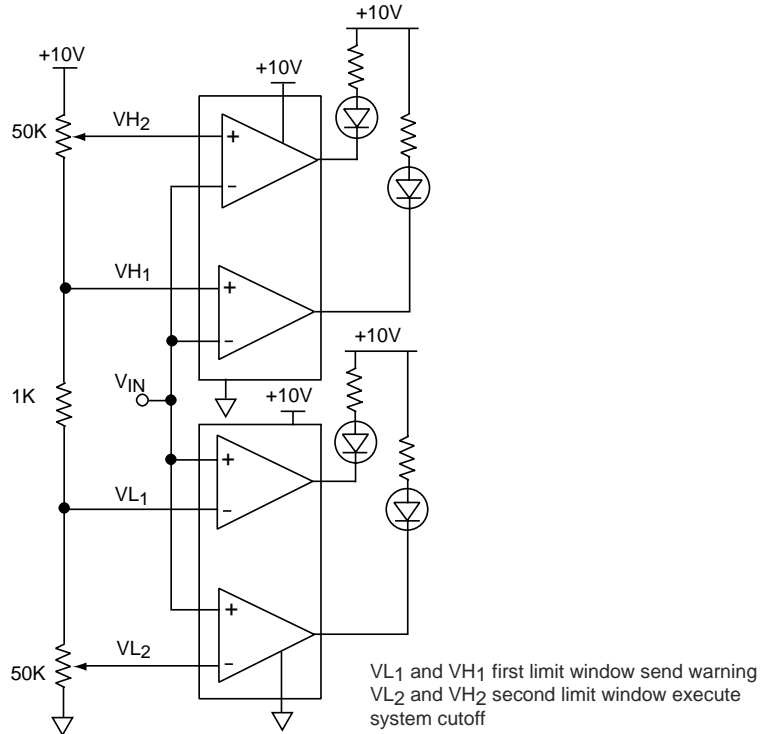

## TYPICAL APPLICATIONS (cont'd)

**VOLTAGE COMPARATOR WITH SINGLE SUPPLY AND OUTPUT LEVEL SHIFT**

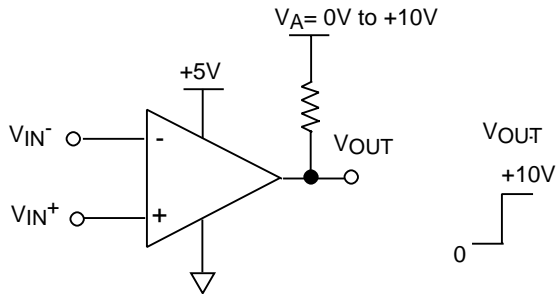

**PRECISION VOLTAGE COMPARATOR WITH COMPLEMENTARY PUSH-PULL OUTPUTS**

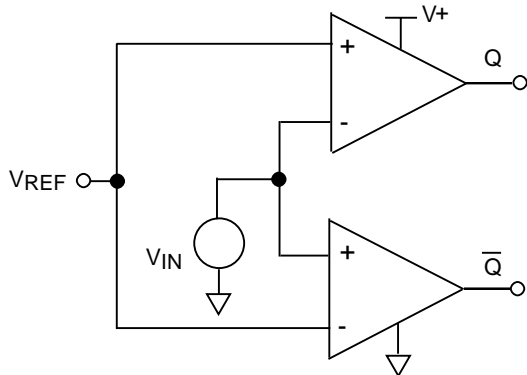

**DOUBLE DUAL PRECISION PHOTO DETECTOR MONITOR**

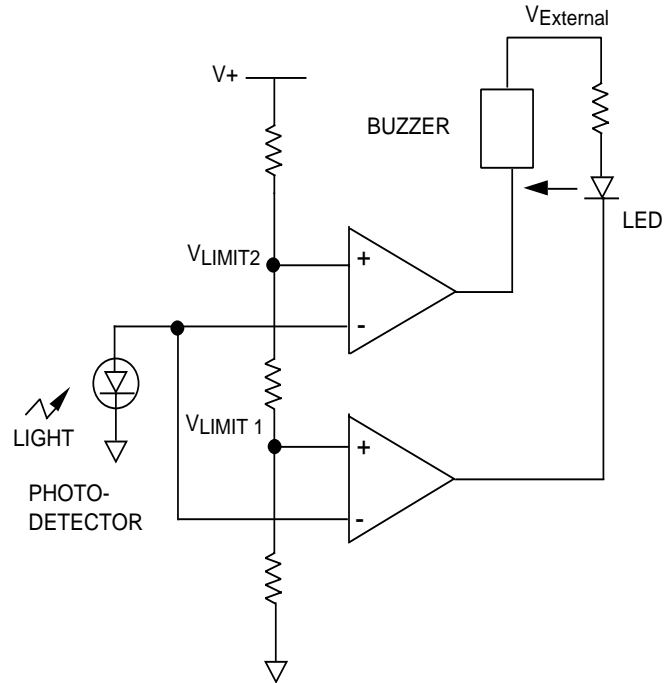

LED turns on as photo-detector voltage reaches  $V_{LIMIT1}$ . Both LED and horn turns on as photo-detector voltage reaches  $V_{LIMIT2}$ .  
 $V_{External} = +10V$ ,  $V+ = +5V$ .

### RESPONSE TIME MEASUREMENT CIRCUIT

Response time is defined as the interval between the application of an input step function and the instant when the output reaches 50% of its maximum value as measured by the following test circuit:

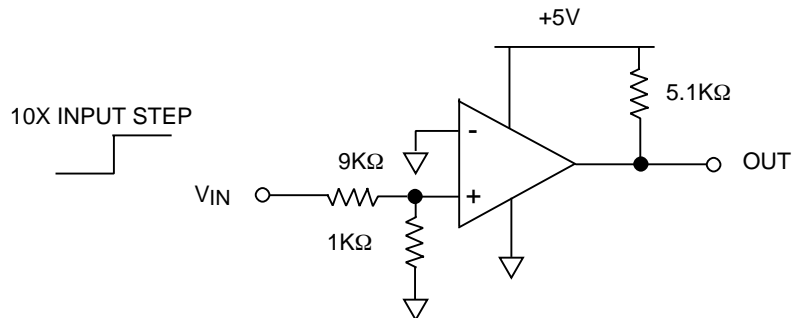

## TYPICAL APPLICATIONS (cont'd)

### PUSH-PULL COMPLEMENTARY POWER MOSFET DRIVER

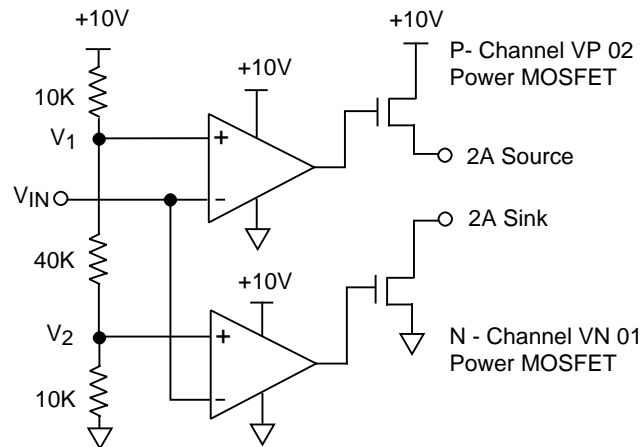

This circuit eliminates crossover current in the complementary power transistors. The outputs can be used to source and sink different loads or tied together to provide push-pull drive of the same load.

### TIME DELAY GENERATOR

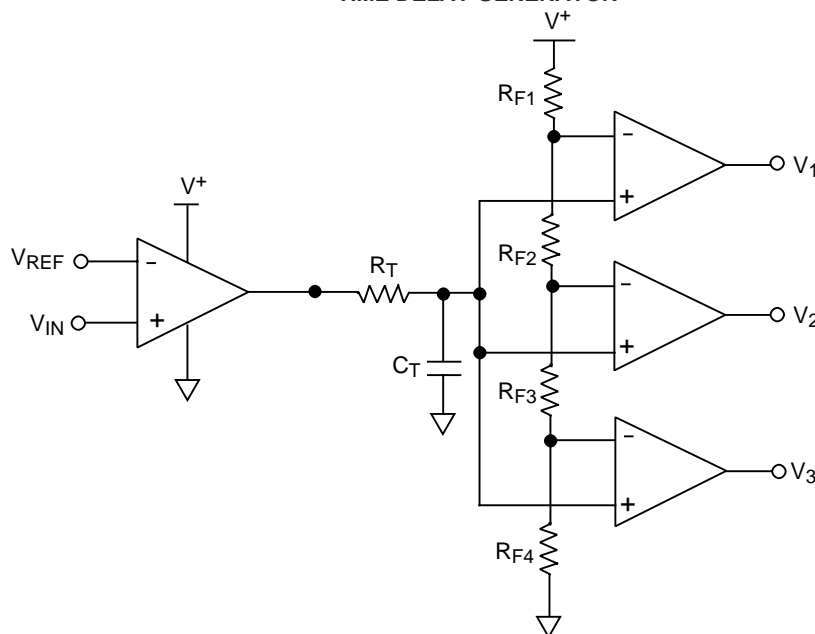

#### Design & Operating Notes:

1. As each output sources up to 10mA in the output high state, the output stage of a wired - OR low output circuit must be able to sink this current and still provide desired output voltage levels. For TTL output levels, this consideration limits the number to a maximum of three ALD2302 outputs wired-OR together.
2. In order to minimize stray oscillation, all unused inputs must be tied to ground.
3. The input bias and offset currents are essentially input protection diode reverse bias leakage currents, and are typically less than 1 pA at room temperature. The currents are a function of ambient temperature, and would have to be considered in applications where very high source impedance or high accuracy are involved.
4. The high output sinking current of 60mA for each output offers flexibility in many applications, as a separate buffer or driver would not be necessary to drive the intended load. However, as the circuit normally operates close to ambient temperature due to its very low power consumption, thermal effects caused by large output current transients must be considered in certain applications.



## TYPICAL APPLICATIONS (cont'd)

**PRECISION DUAL LIMIT WINDOW COMPARATAOR**

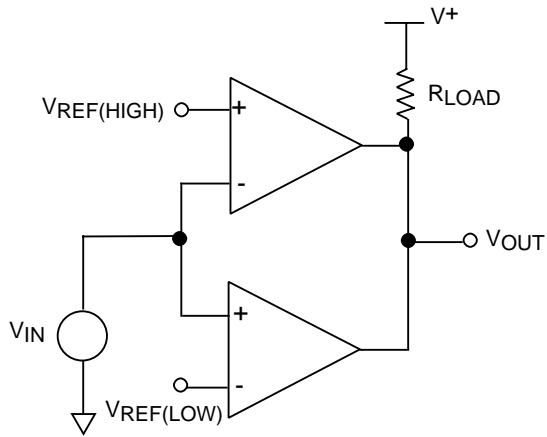

$R_{LOAD} = 1.5K\Omega$   
 OUTPUT HIGH FOR  $V_{IN} < V_{REF(HIGH)}$   
 AND  $V_{IN} > V_{REF(LOW)}$

**VOLTAGE LEVEL TRANSLATOR**

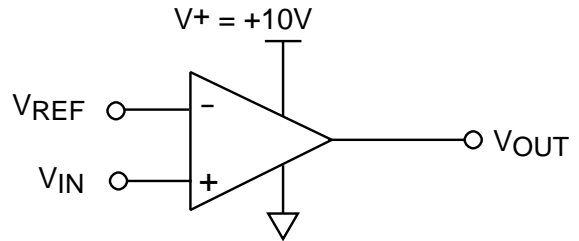

$V_{REF} = 1.4V$  for TTL input

$V_{REF} = \frac{V^+}{2}$  for CMOS input

Output  $V_{OUT}$  swings from rail-to-rail

**PRECISION VOLTAGE COMPARATOR WITH +/-5V SUPPLY AND OUTPUT LEVEL SHIFT**

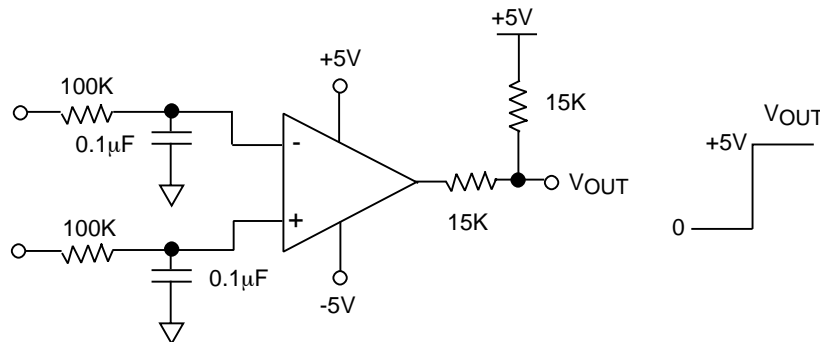

**PRECISION VOLTAGE COMPARATOR WITH OUTPUT LEVEL SHIFT AND HIGH CURRENT LOAD DRIVER**

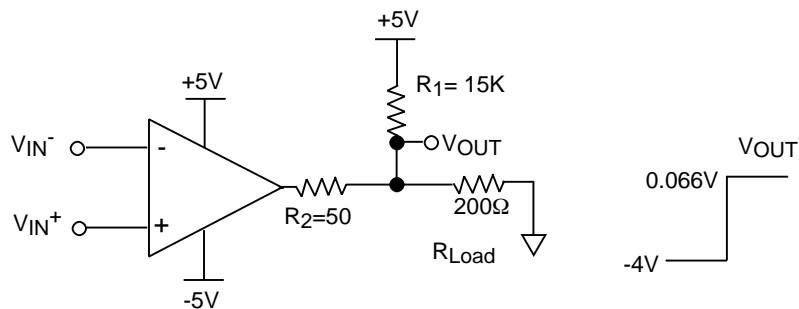

# SOIC-8 PACKAGE DRAWING

## 8 Pin Plastic SOIC Package

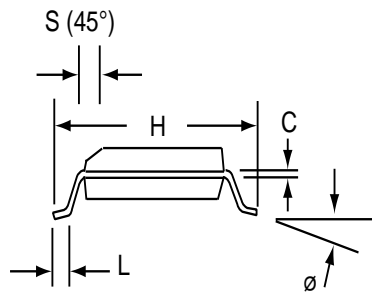
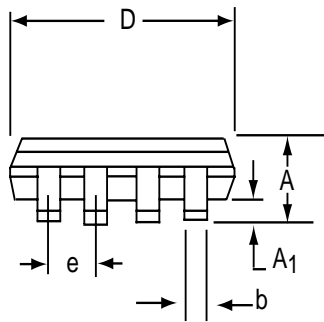
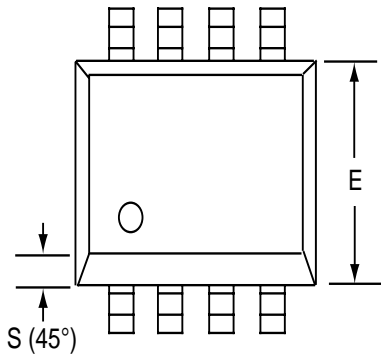

Dim	Millimeters		Inches	
	Min	Max	Min	Max
A	1.35	1.75	0.053	0.069
A <sub>1</sub>	0.10	0.25	0.004	0.010
b	0.35	0.45	0.014	0.018
C	0.18	0.25	0.007	0.010
D-8	4.69	5.00	0.185	0.196
E	3.50	4.05	0.140	0.160
e	1.27 BSC		0.050 BSC	
H	5.70	6.30	0.224	0.248
L	0.60	0.937	0.024	0.037
Ø	0°	8°	0°	8°
S	0.25	0.50	0.010	0.020

# PDIP-8 PACKAGE DRAWING

## 8 Pin Plastic DIP Package

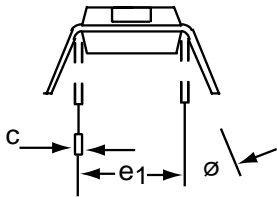
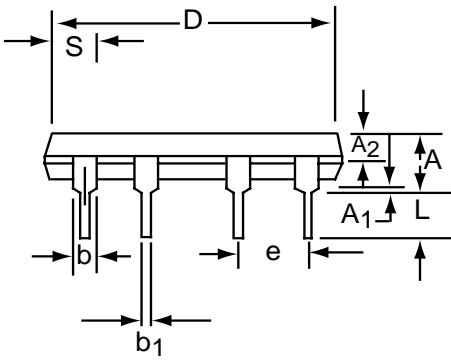
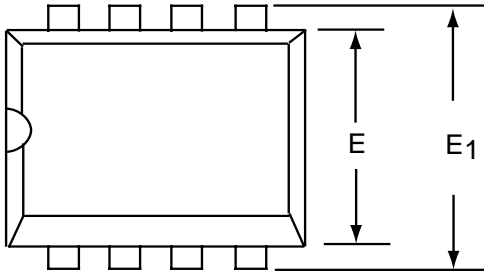

Dim	Millimeters		Inches	
	Min	Max	Min	Max
A	3.81	5.08	0.105	0.200
A <sub>1</sub>	0.38	1.27	0.015	0.050
A <sub>2</sub>	1.27	2.03	0.050	0.080
b	0.89	1.65	0.035	0.065
b <sub>1</sub>	0.38	0.51	0.015	0.020
c	0.20	0.30	0.008	0.012
D-8	9.40	11.68	0.370	0.460
E	5.59	7.11	0.220	0.280
E <sub>1</sub>	7.62	8.26	0.300	0.325
e	2.29	2.79	0.090	0.110
e <sub>1</sub>	7.37	7.87	0.290	0.310
L	2.79	3.81	0.110	0.150
S-8	1.02	2.03	0.040	0.080
∅	0°	15°	0°	15°