

**0.9Ω/ 1Ω Dual SPDT Analog Switch****Features**

- Maximum 0.9Ω ON-State Resistance at 2.7V Supply for NC Switch
- Maximum 1Ω ON-State Resistance at 2.7V Supply for NO Switch
- Low Charge Injection
- Excellent ON Resistance Matching
- +2.7V to +5.5V Single-Supply Operation
- Low Total Harmonic Distortion
- Low supply Current (<0.2μA)
- Break-before-make Enable Circuitry
- Control Inputs 5V Tolerant
- WLCSP Package and TDFN 3X3 Package

Applications

- Speaker Headset Switching
- MP3 Players
- Power Routing
- Battery-Operated Equipment
- Relay Replacement
- Audio and Video Signal Routing
- Communication circuits
- PCMCIA Cards
- Cellular Phones
- Modems

General Description

The G3203 is a low on-resistance, dual SPDT (Single-Pole/Double-Throw) analog switch that operates from a 2.7V to 5.5V supply. The G3203 features a 0.9Ω (max) R_{ON} for its NC switch and a 1Ω(max) R_{ON} for its NO switch at a +2.7V supply. The device offers an excellent ON-resistance matching, and low total harmonic distortion (THD) performance. The device is designed for fast switching speeds with the break-before-make feature to prevent signal distortion during the transferring of signal from one channel to another. These features make this device suitable for portable audio applications.

The G3203 is available in the WLCSP3X4-10, WLCSP3X4-12 and TDFN3X3-10 package.

Ordering Information

ORDER NUMBER	MARKING	TEMP. RANGE	PACKAGE (Pb free)
G3203RE1U	3203	-40°C to 85°C	TDFN3X3-10
G3203B51U	323x	-40°C to 85°C	WLCSP3X4-12
G3203B52D	32032	-40°C to 85°C	WLCSP3X4-10

Note :RE: TDFN3X3-10 B51: WLCSP3X4-12 B52: WLCSP3X4-10
 1: Bonding Code (only TDFN3X3-10)
 U & D: Tape & Reel

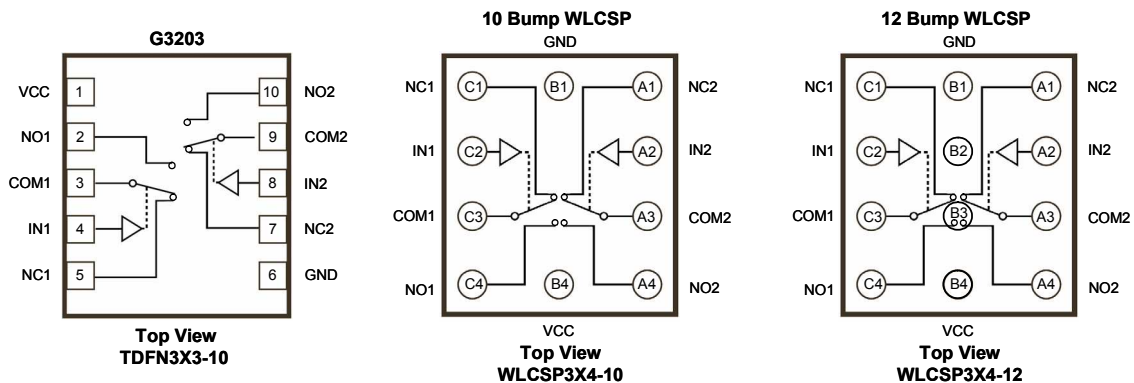
Pin Configuration

Summary of Characteristics ⁽¹⁾

CONFIGURATION	DUAL SPST
Number of channels	2
On-State resistance (r_{on}) of NC/NO	0.9Ω/1Ω
On-State resistance match (Δr_{on}) of NC/NO	0.25Ω/0.25Ω
On-State resistance flatness ($r_{on(flat)}$) of NC/NO	0.4Ω/0.4Ω
Turn-on / Turn-off time (t_{ON} / t_{OFF})	15ns / 14ns
Charge injection (Q_C)	20pC
Bandwidth (BW)	20MHz
OFF isolation (O_{ISO})	- 74dB at 100kHz
Crosstalk (X_{TALK})	- 72dB at 100kHz
Total harmonic distortion (THD)	0.1%
Power-supply current (I_+)	0.2μA
Package options	WCSP3X4-10, WCSP3X4-12 and TDFN3X3-10

(1) $V_+ = 5V$, $T_A = 25^\circ C$ and the value are the worst one.

Function Table

IN_	NO_	NC_
0	OFF	ON
1	ON	OFF

Absolute Maximum Ratings

VCC supply voltage to GND. -0.3V to +7V
 IN1, IN2 input voltage to GND -0.3 to +7V
 NO, NC, COM switch I/O voltage to GND. . -0.3 to +7V
 Output Short-Current Indefinite
 Maximum Junction Temperature 150°C

Continuous Current NO_NC_COM ±500mA
 Operating Temperature Range -40°C to 85 °C
 Storage Temperature Range. -65 °C to 150°C
 Reflow Temperature (soldering, 10sec) 260°C
 ESD(HBM)(Note 1) 2KV

Note 1 : Human body model is a 100pF capacitor discharged through a 1.5kΩ resistor into each pin.

Electrical Characteristics

T_A=25°C, unless otherwise noted.

PARAMETER	CONDITIONS	MIN	TYP	MAX	UNITS
DC Characteristics					
Analog signal range		0	---	V+	V
NC On-Resistance, R _{ON(NC)}	V+=2.7, I _{COM} =100mA, V _{NC} =0 to V+	---	0.45	0.9	Ω
	V+=4.5, I _{COM} =100mA, V _{NC} =0 to V+				
	V+=2.7, I _{COM} =100mA, V _{NC} =0 to V+	---	0.45	0.9	
	V+=4.5, I _{COM} =100mA, V _{NC} =0 to V+				
NO On-Resistance, R _{ON(NO)}	V+=2.7; I _{COM} =100mA; V _{NO} =0 to V+	---	0.6	1	Ω
	V+=4.5, I _{COM} =100mA, V _{NO} =0 to V+	---	0.6	1	
On-Resistance Match Between Switches, ΔR _{ON}	V+=2.7, I _{COM} =100mA, V _{NO} or V _{NC} =1.5V	---	0.1	0.25	Ω
	V+=4.5, I _{COM} =100mA, V _{NO} or V _{NC} =2.5V	---	0.1	0.25	
NC On-Resistance Flatness, R _{FLAT(NC)}	0 ≤ V _{NC} ≤ V+, I _{COM} =100mA, V+=2.7V	---	0.12	0.4	Ω
	0 ≤ V _{NC} ≤ V+, I _{COM} =100mA, V+=4.5V	---	0.16	0.4	
NO On-Resistance Flatness, R _{FLAT(NO)}	0 ≤ V _{NO} ≤ V+, I _{COM} =100mA, V+=2.7V	---	0.2	0.4	Ω
	0 ≤ V _{NO} ≤ V+, I _{COM} =100mA, V+=4.5V	---	0.16	0.4	
NO or NC Off leakage current, I _{NO(OFF)} or I _{NC(OFF)}	V+=5.5V, V _{NO} or V _{NC} =1V, 4.5V, V _{COM} =4.5V, 1V	---	---	20	nA
COM On Leakage Current, I _{COM(ON)}	V+=5.5V, V _{NO} =1V or 4.5V with V _{NC} floating, or V _{NC} =1V or 4.5V with V _{NO} floating, V _{COM} =1V or 4.5V	---	---	20	nA
Input Logic High, V _{IH}	V+=3V	1.4	---	---	V
	V+=5V	2	---	---	
Input Logic Low, V _{IL}	V+=3V	---	---	0.5	V
	V+=5V	---	---	0.8	
Input leakage Current	V _{IN} =5.5V or 0V, V+=5.5V	---	---	1	μA
Supply Current, I+	V _{IN} =0 or 5.5V, V+=5.5V	---	---	0.2	μA
Dynamic					
Turn-On Time, t _{ON}	V+=3V, V _{NO} or V _{NC} =1.5V, R _L =50Ω; C _L =35pF	---	26	50	ns
	V+=5V, V _{NO} or V _{NC} =2.5V, R _L =50Ω; C _L =35pF	---	16	40	
Turn-Off Time, t _{OFF}	V+=3V, V _{NO} or V _{NC} =1.5V, R _L =50Ω; C _L =35pF	---	14	40	ns
	V+=5V, V _{NO} or V _{NC} =2.5V, R _L =50Ω; C _L =35pF	---	16	30	
Break-Before Make Time, t _{BBM}	V+=3V, V _{NO} =V _{NC} =1.5V, R _L =300 ohm; C _L =35pF	7.8	10	---	ns
Charge injection, Q _C	V+=3V, COM =0V; R _S =0V, C _L =1nF	---	30	---	pC
OFF isolation, O _{ISO}	V+=3V, R _L =50Ω, C _L =5pF; f=100kHz, V _{COM} =1V _{RMS} , Switch OFF	---	-74	---	dB
Crosstalk, X _{Talk}	V+=3V, R _L =50Ω, C _L =5pF; f=100kHz, V _{COM} =1V _{RMS} , Switch OFF	---	-72	---	dB
Total harmonic distortion, THD	V+=3V, R _L =600Ω, C _L =50pF, V _{IN} =1V _{RMS} , f= 20Hz to 20kHz	---	0.1	---	%
3 db Bandwidth, BW	Input centered between V+ and GND, R _L =50Ω	---	20	---	MHz
NO OFF capacitance, C _{NO(OFF)}	V+=5V, f=1MHz	---	79	---	pF
NC OFF capacitance, C _{NC(OFF)}	V+=5V, f=1MHz	---	95	---	pF
NO ON capacitance, C _{NO(ON)}	V+=5V, f=1MHz	---	211	---	pF
NC ON capacitance, C _{NC(ON)}	V+=5V, f=1MHz	---	273	---	pF

Typical Performance Characteristics

$T_A = 25^\circ\text{C}$, unless otherwise specified.

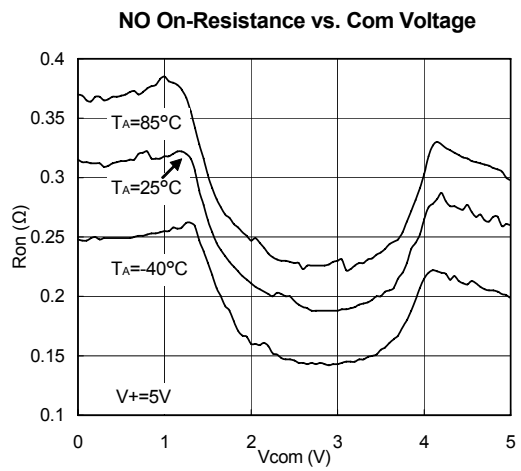
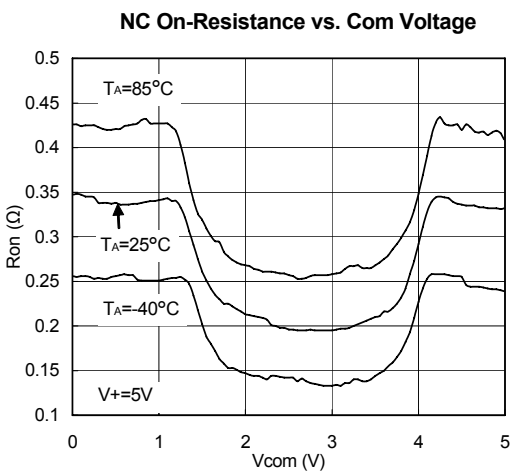
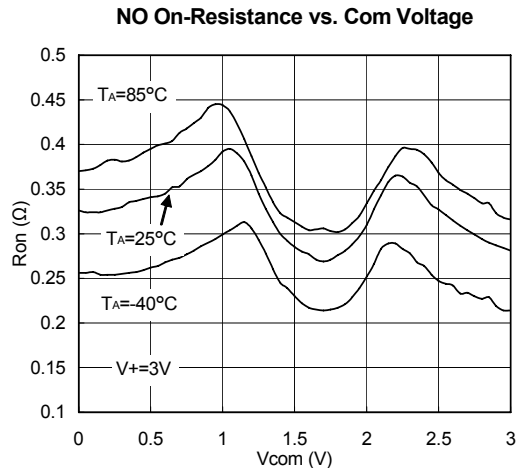
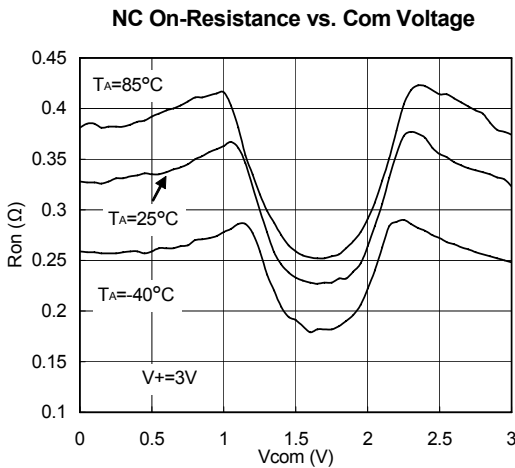
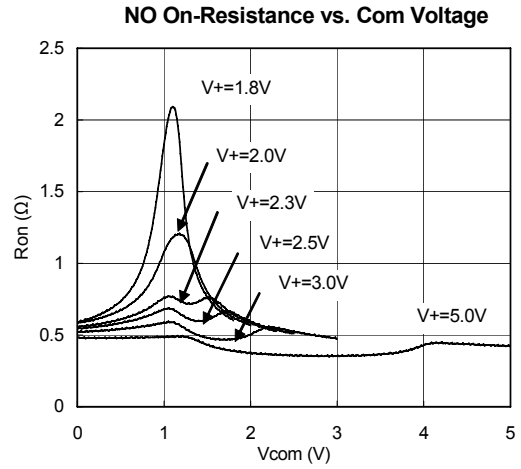
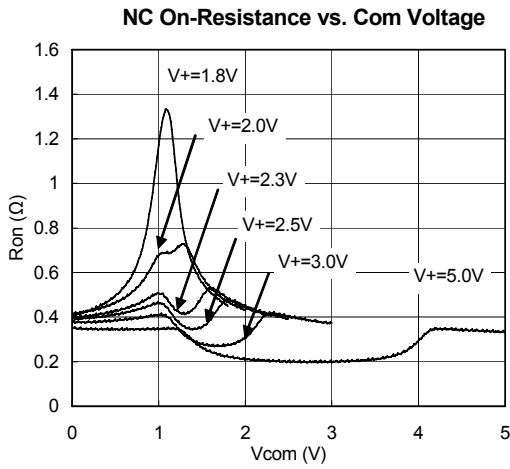

Typical Performance Characteristics (Continued)

Supply Current vs. Supply Voltage

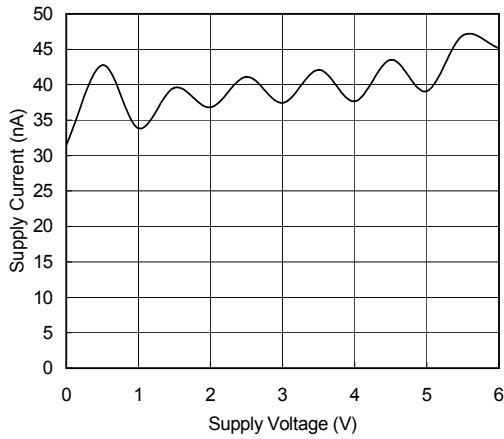

Logic Threshold Voltage vs. Supply Voltage

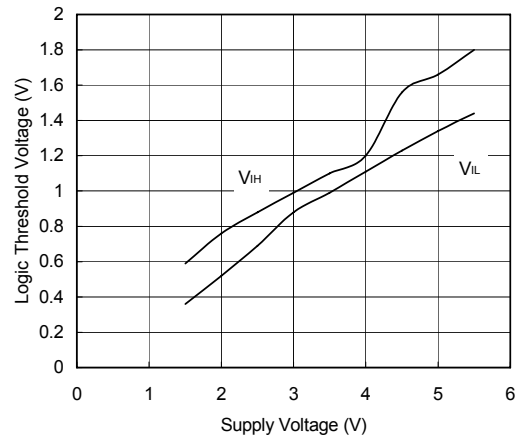

Com Leakage Current vs. Temperature

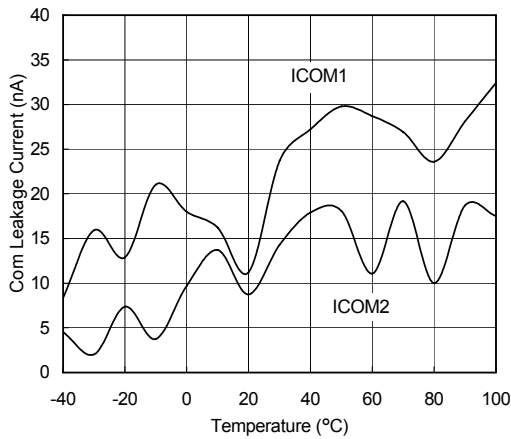

Turn -on/Turn-off Times vs. Supply Voltage

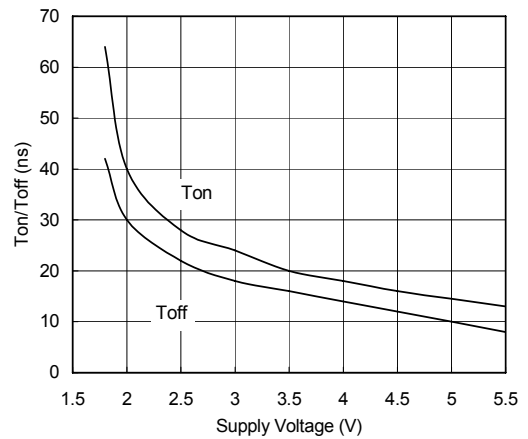

Charge Injection vs. Com Voltage

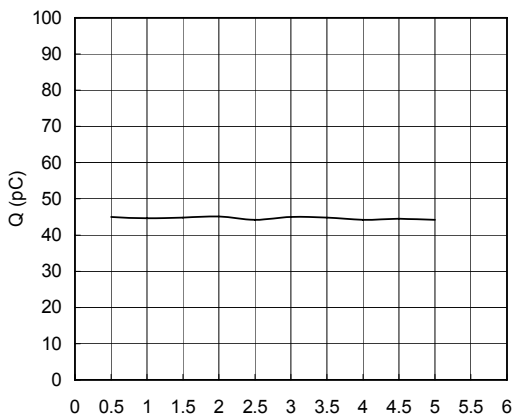

THD+N vs. Frequency

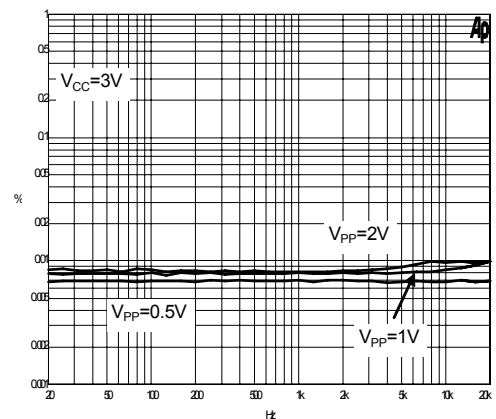

Typical Performance Characteristics (Continued)

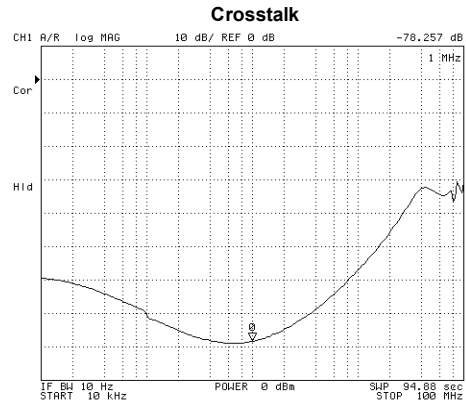
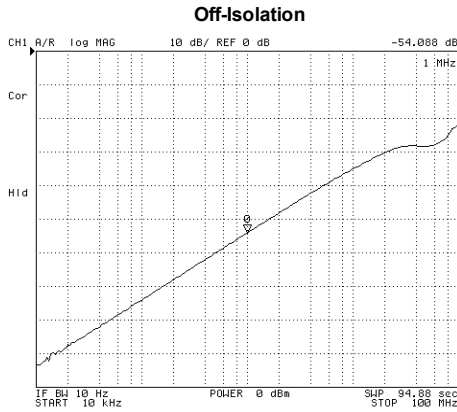

Recommended Minimum Footprint

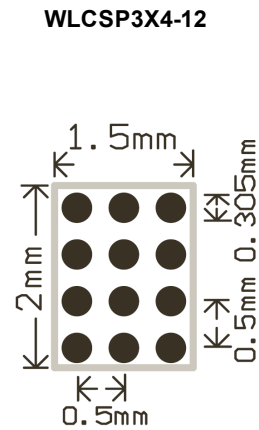
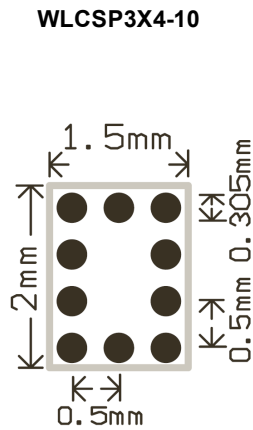
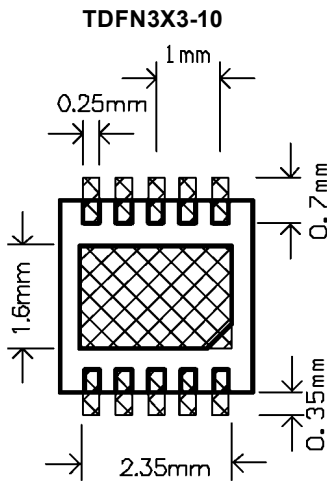

Pin Descriptions

PIN			NAME	FUNCTION
TDFN3X3-10	WLCSP3X4-10	WLCSP3X4-12		
1	B4	B4	VCC	Power supply
2	C4	C4	NO1	Normally open
3	C3	C3	COM1	Common
4	C2	C2	IN1	Digital control pin
5	C1	C1	NC1	Normally close
6	B1	B1	GND	Digital ground
7	A1	A1	NC2	Normally close
8	A2	A2	IN2	Digital control pin
9	A3	A3	COM2	Common
10	A4	A4	NO2	Normally open
---	---	B2,B3	NC	No connection

Test Circuits/ Timing Diagrams

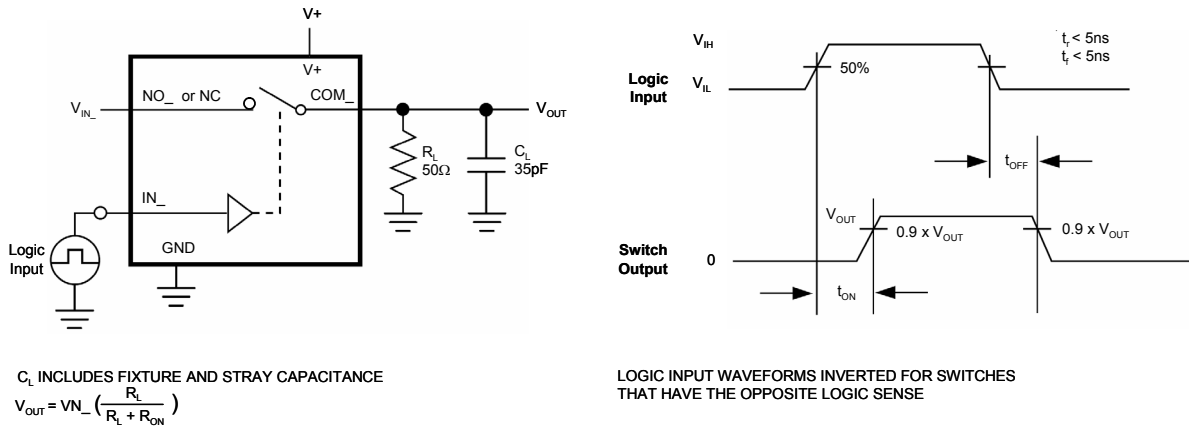

Figure 1. Switching Time

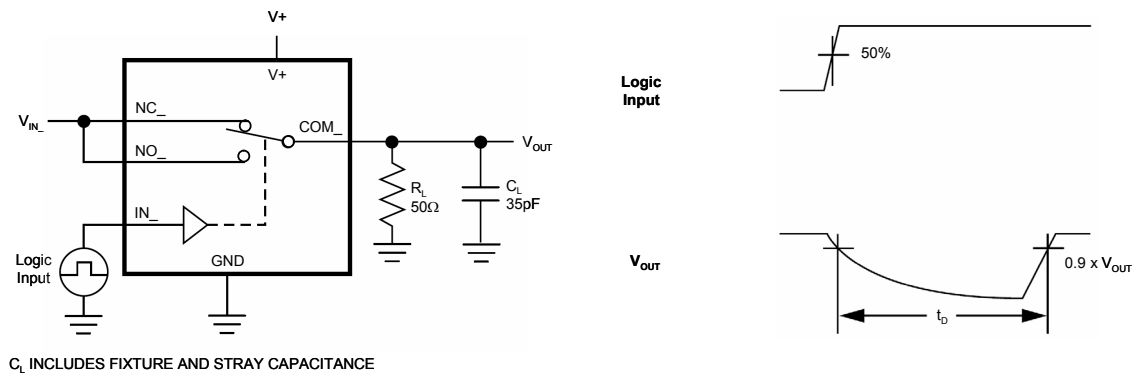

Figure 2. Break Before Make Interval

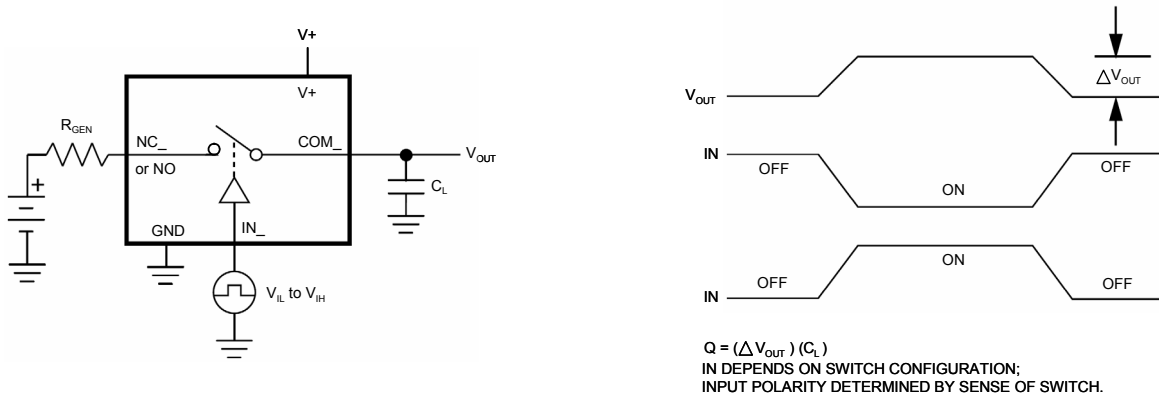
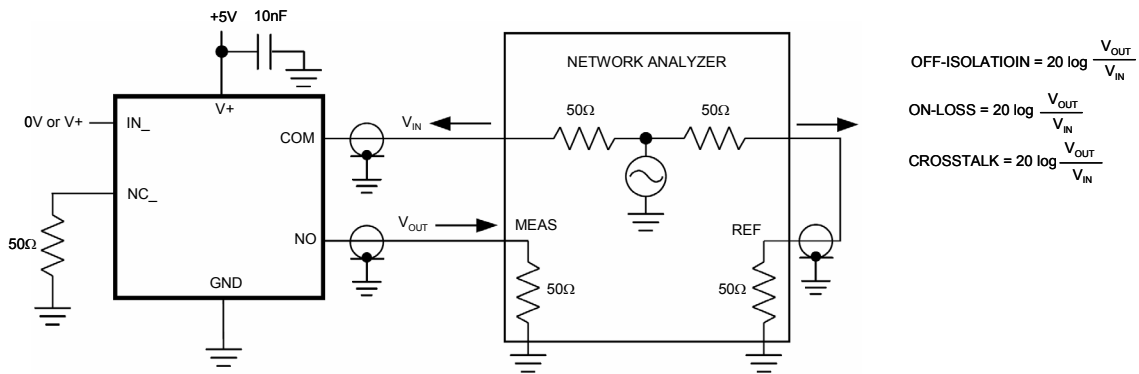

Figure 3. Charge Injection



MEASUREMENTS ARE STANDARDIZED AGAINST SHORTS AT IC TERMINALS.
OFF-ISOLATION IS MEASURED BETWEEN COM_ AND "OFF" NO_ OR NC_ TERMINAL ON EACH SWITCH.
ON-LOSS IS MEASURED BETWEEN COM_ AND "ON" NO_ OR NC_ TERMINAL ON EACH SWITCH.
CROSSTALK IS MEASURED FROM ONE CHANNEL TO ALL OTHER CHANNELS.
SIGNAL DIRECTION THROUGH SWITCH IS REVERSED; WORST VALUES ARE RECORDED.

Figure 4. On-Loss, Off-Isolation, and Crosstalk

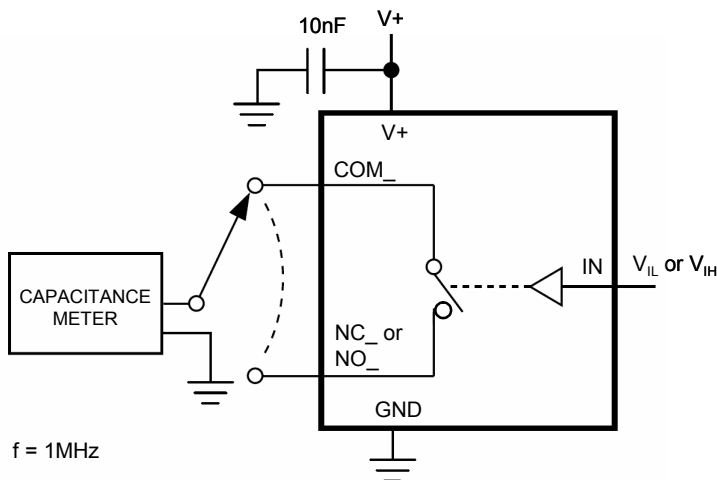
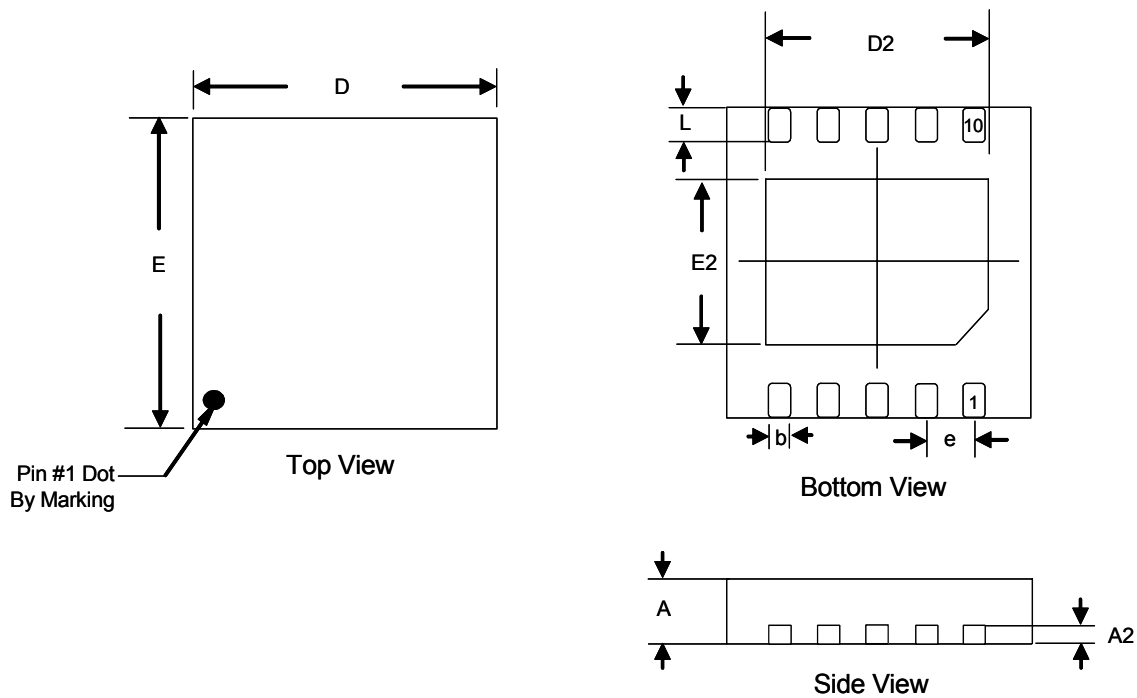

Figure 5. Channel Off/On Capacitance

Package Information



TDFN3X3-10 Package

SYMBOL	DIMENSION IN MM			DIMENSION IN INCH		
	MIN.	NOM.	MAX.	MIN.	NOM.	MAX.
A	0.700	0.750	0.800	0.028	0.030	0.031
A2	0.195	0.203	0.211	0.008	0.008	0.008
b	0.180	0.250	0.300	0.007	0.010	0.012
D	2.950	3.000	3.050	0.116	0.118	0.120
D2	2.300	2.350	2.400	0.091	0.093	0.094
E	2.950	3.000	3.050	0.116	0.118	0.120
E2	1.550	1.600	1.650	0.061	0.063	0.065
e	0.500 BSC			0.020 BSC		
L	0.350	0.400	0.450	0.014	0.016	0.018

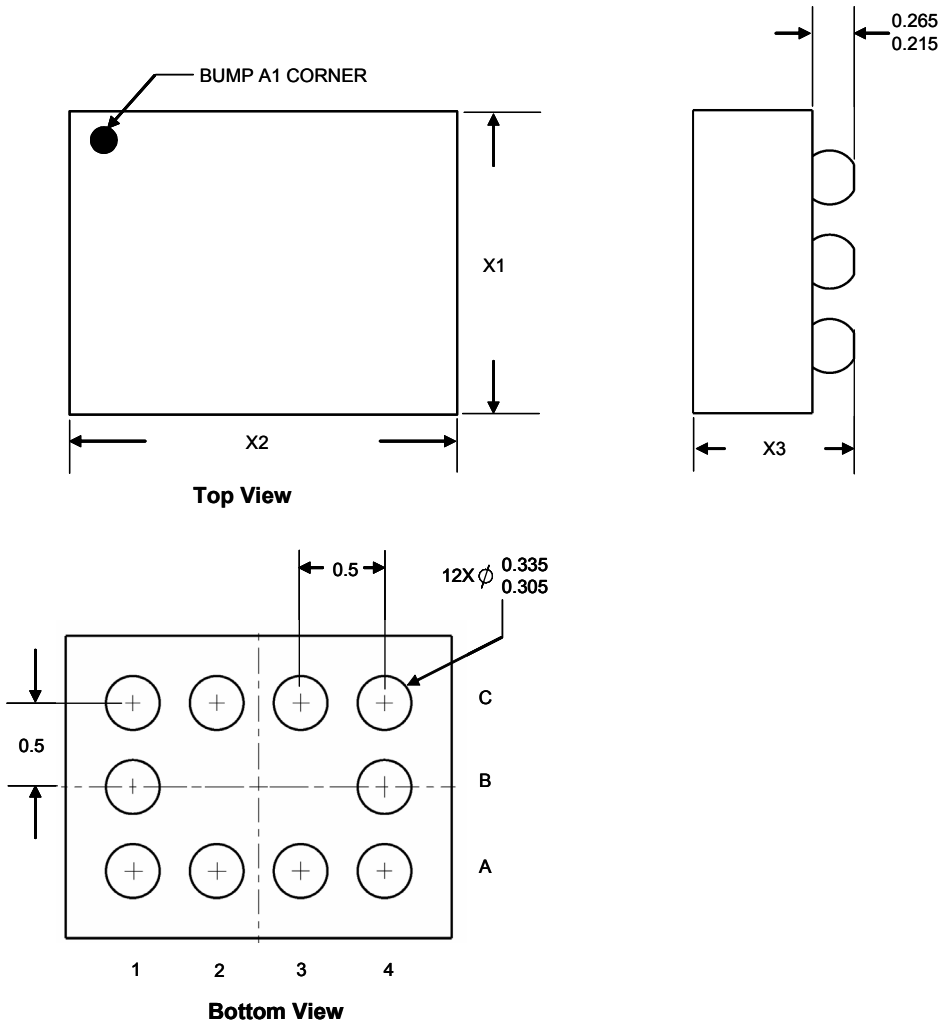

Note: 1. Unless Otherwise Specified
 2. Reference JEDEC Registration MO-211.

WLCSP3X4-10 Package

SYMBOL	DIMENSION IN MM			DIMENSION IN INCH		
	MIN.	NOM.	MAX.	MIN.	NOM.	MAX.
X1	1.450	1.470	1.500	0.057	0.058	0.059
X2	1.950	1.970	2.000	0.077	0.078	0.079
X3	0.560	0.600	0.640	0.022	0.024	0.025

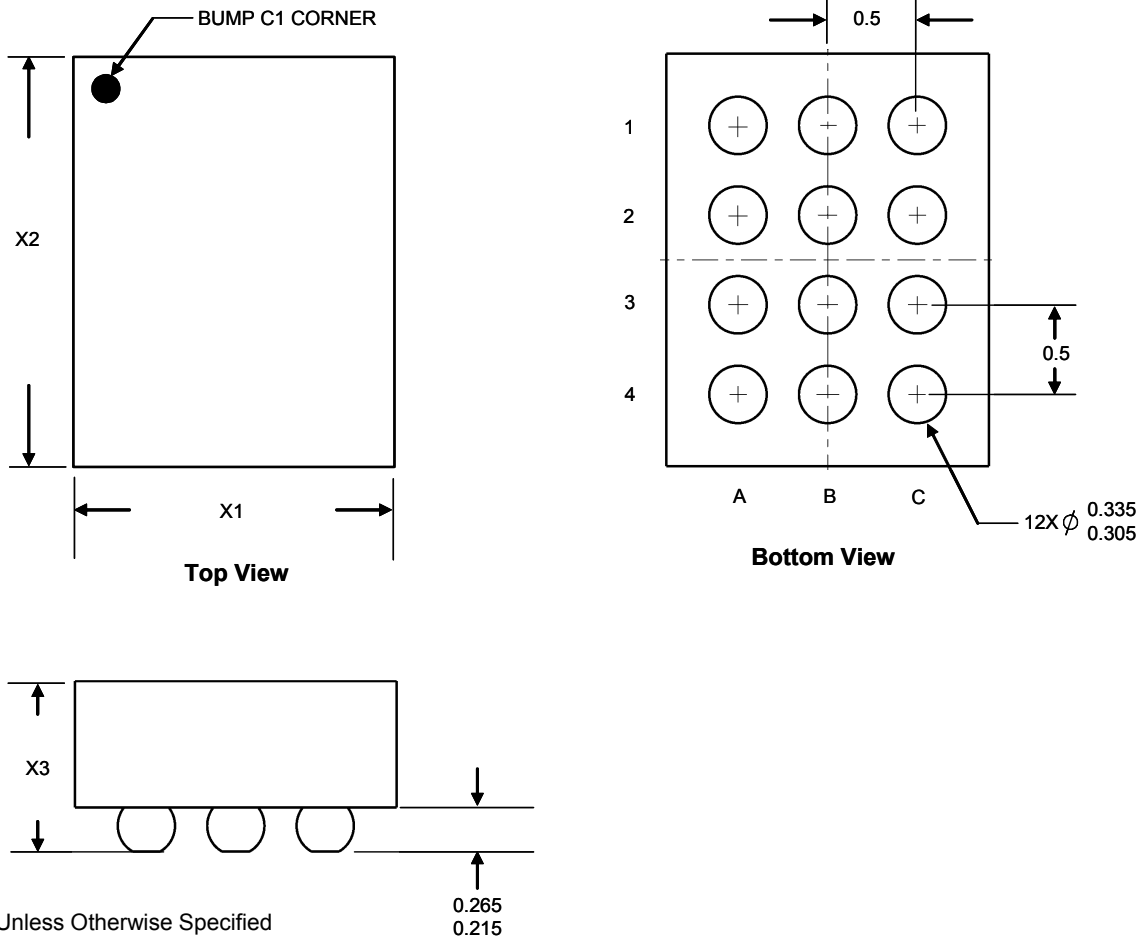

WLCSP3X4-12 Package

SYMBOL	DIMENSION IN MM			DIMENSION IN INCH		
	MIN.	NOM.	MAX.	MIN.	NOM.	MAX.
X1	1.450	1.470	1.500	0.057	0.058	0.059
X2	1.950	1.970	2.000	0.077	0.078	0.079
X3	0.560	0.600	0.640	0.022	0.024	0.025

Taping Specification

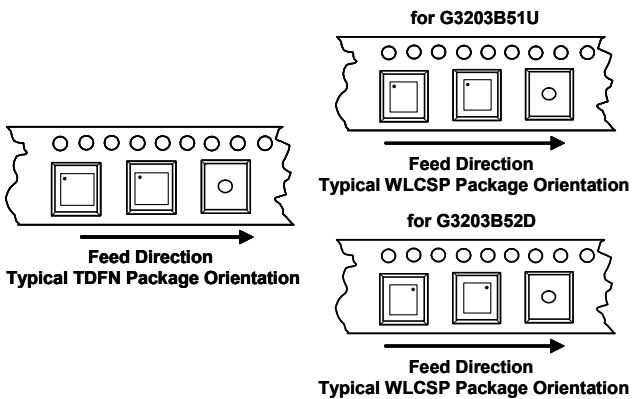

PACKAGE	Q'TY/REEL
TDFN3X3-10	3,000 ea
WLCSP3X4	3,000 ea

GMT Inc. does not assume any responsibility for use of any circuitry described, no circuit patent licenses are implied and GMT Inc. reserves the right at any time without notice to change said circuitry and specifications.