

2.6W Stereo Audio Amplifier with Shutdown Mode

Features

- Depop Circuitry Integrated
- 3V to 5.5V Operation
- Output Power at 10% THD+N, VDD=5V
--2.6W (typical) into a 3Ω Load
- Output Power at 1% THD+N, VDD=5V
--2W (typical) into a 4Ω Load
--1.3W (typical) into a 8Ω Load
- Stereo Bridge-Tied Load (BTL)
- Shutdown Control Available
- TQFN3X3-16 Package Available

Applications

- PDAs
- Portable Devices
- Notebook

General Description

The G1453/G1453L is a stereo audio power amplifier in 16 pin TQFN3X3-16 with thermal pad package. It can drive 2W continuous RMS power into 4Ω load in Bridge-Tied Load (BTL) mode at 5V supply voltage. Its THD is smaller than 1% under the above operation condition. For the low current consumption applications, the SHUTDOWN mode is supported to disable the G1453/G1453L when it is idle. The current consumption can be further reduced to below 1μA.

Giving the $\overline{\text{SHUTDOWN}}$ pin low level will drive the G1453L entering the shutdown.

Giving the SHUTDOWN pin high level will drive the G1453 entering the shutdown

Ordering Information

ORDER NUMBER	MARKING	TEMP. RANGE	PACKAGE (Green)
G1453R41U	1453	-40°C to +85°C	TQFN3X3-16
G1453LR41U	1453L	-40°C to +85°C	TQFN3X3-16

Note: R4: TQFN3X3-16

1: Bonding Code

U: Tape & Reel

Pin Configuration

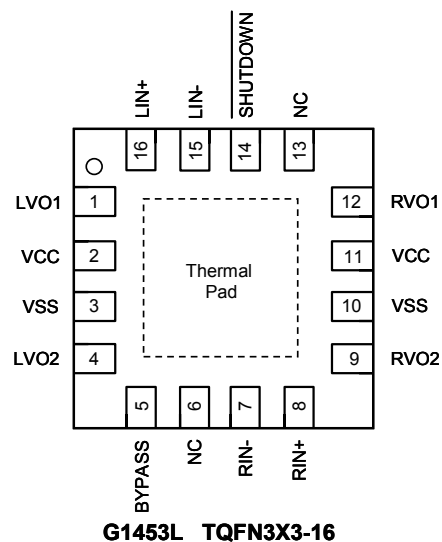
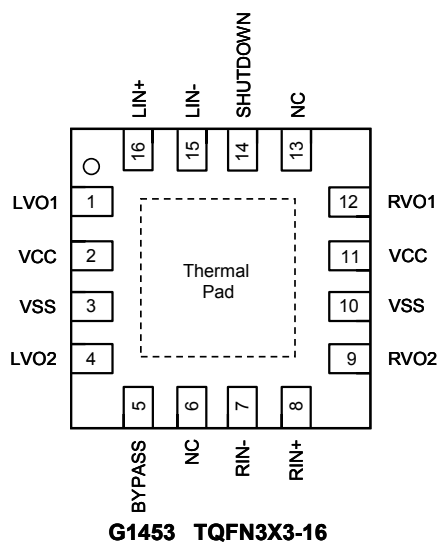

Note: Recommend connecting the Thermal Pad to the Ground for excellent power dissipation.