

## Low Power Quadruple Operational Amplifiers

### Features

- Wide Supply Operation Range +4.5V to +16V
- Input Common Voltage Range Beyond the Rails
- Rail-to-Rail Output Voltage Swing
- Low Input Offset Voltage 3mV (Typical)
- Wide Bandwidth (unit gain) 4MHz
- Low Quiescent Current: 500µA per Amplifier
- Large DC Voltage Gain 100dB (Typical)
- Slew-Rate 5.5V/us
- Unit-Gain Stable

### Applications

- Portable Equipment
- LCD-TV Equipment
- Battery-Powered Equipment
- ASIC Input or Output Amplifier
- Low Power/Low Voltage Applications

### General Description

The G1540 consists of four independent, high gain, internally frequency compensated operational amplifiers which were designed to operate from a single power supply over a wide range of voltages. Operation from split power supplies is also possible. The input common mode range of the G1540 can be beyond the rails, and the G1540 are with rail-to-rails output voltage swing. The quiescent current is 500µA per amplifier.

The G1540 also feature fast slewing and settle-times, as well as high output drive capability of 60mA (source/sink). These features make these amplifiers ideal for use as reference buffers for TFT-LCD. Other applications include battery power, portable devices, and anywhere low power consumption is important.

The G1540 is housed in a 14-pin SOP, TSSOP and TQFN4X4-16 packages.

### Ordering Information

ORDER NUMBER	MARKING	TEMP. RANGE	PACKAGE (Green)
G1540P21U	G1540	-40°C~+85°C	SOP-14
G1540D21U	G1540	-40°C~+85°C	TSSOP-14
G1540R81U	1540	-40°C~+85°C	TQFN4X4-16

Note: P2 : SOP-14    D2:TSSOP-14    R8: TQFN4X4-16

1: Bonding Code

U: Tape & Reel

### Pin Configuration

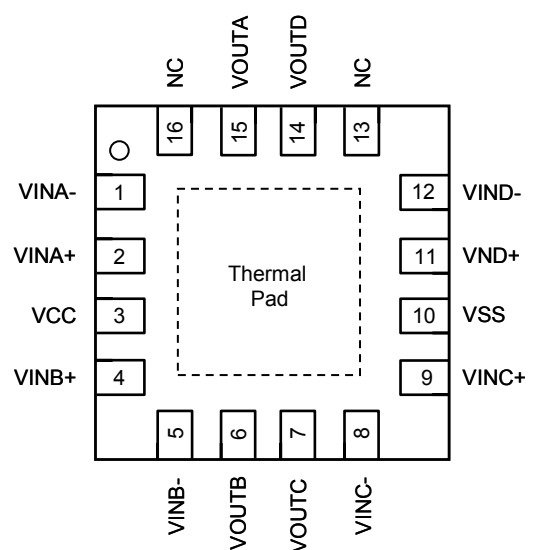
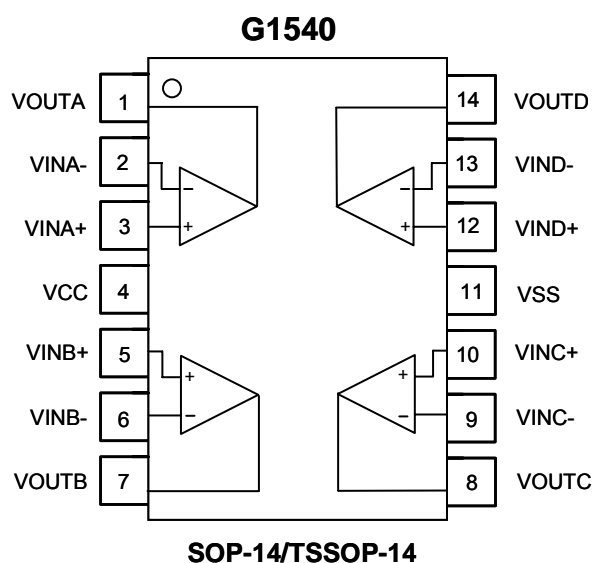

**G1540 TQFN4X4-16**

Note: Recommend connecting the Thermal Pad to the Ground for excellent power dissipation.