

# Motor Controllers

## AC Semiconductor Motor Controller

### Type RSHP Flexy

CARLO GAVAZZI



- Soft starting and stopping of 3-phase induction squirrel cage motors
- 2-phase control with integral bypassing of semi-conductors
- Low inrush and reduced vibration during starting
- User-selected ramping profiles
- Rated operational voltage: up to 600VAC, 50/60 Hz
- Rated operational current up to 45A AC-53b
- LED status indicators
- Device over-temperature protection
- Motor PTC protection
- Kickstart option for high torque loads
- Auxiliary relay for top of ramp and alarms
- DIN rail or panel mounting

## Product Description

The RSHP Flexy is a micro-processor-based softstarter for 3-phase induction motors in a compact new format. While offering versatile ramping features, Flexy is also very easy to configure. It is possible to match the start/stop ramping profiles with the functional requirements of specific motor loads. A clever push-button and LED user interface eliminates the added cost of an alphanumeric display. The RSHP Flexy uses an in-house designed system that ensures efficient power management.

## Ordering Key

**RSH P 40 25 C V21**

H-line Motor Controller \_\_\_\_\_  
 Push button selector \_\_\_\_\_  
 Rated operational voltage \_\_\_\_\_  
 Rated operational current \_\_\_\_\_  
 Control voltage \_\_\_\_\_  
 Options \_\_\_\_\_

## Selection Guide

Rated operational voltage $U_e$	Rated operational current $I_e$		
	25A AC-53b	38A AC-53b	45A AC-53b
220VACrms	RSHP2225CV21	RSHP2238CV21	RSHP2245CV21
400VACrms	RSHP4025CV21	RSHP4038CV21	RSHP4045CV21
480VACrms	RSHP4825CV21	RSHP4838CV21	RSHP4845CV21
600VACrms	RSHP6025DV21	RSHP6038DV21	RSHP6045DV21

## Supply Specification

Rated operational voltage $U_e$ through L1, L2, L3	RSHP22..	127/220 VAC-15% /+10%
	RSHP40..	230/400 VAC-15% /+10%
	RSHP48..	277/480 VAC-15% /+10%
	RSHP60..	346/600 VAC-15% /+10%
Rated AC frequency	50/60 Hz±10%	
Dielectric strength		
Dielectric voltage	2 kV (rms)	
Rated impulse withstand volt.	4 kV (1.2/50µs)	

## Input Specifications

Rated control input voltage $U_c$ , A1-A2:	C: 24-550 VAC/DC D: 24-600 +10% VAC/DC
Rated control input current	<1.5 mA
Rated AC frequency	50/60 Hz±10%
Dielectric strength	
Dielectric voltage	2kVAC (rms)
Rated impulse withstand volt.	4kV (1.2/50 µs)

## Load Ratings

	RSHP..25.V21	RSHP..38.V21	RSHP..45.V21
IEC rated operational current $I_e$ (AC-53b)	25 A	38A	45 A
Assigned motor rating @ 60°C/ UL rating @ 60°C			
RSHP22..	5.5kW / 10HP	11kW / 10HP	11kW / 15HP
RSHP40..	11kW / 15HP	18.5kW / 20HP	22kW / 25HP
RSHP48..	15kW / 20HP	22kW / 25HP	30kW / 30HP
RSHP60..	18.5kW / 25HP	22kW / 30HP	30kW / 40HP
Overload cycle according to IEC/EN 60947-4-2 @ 40°C	25A:AC-53b:4-5:65	38A: AC-53b: 4-5:85	45A: AC-53b: 4-5: 115
@ 50°C	25A:AC-53b:4-5:85	38A:AC-53b:4-5:175	45A: AC-53b: 4-5: 135
@ 60°C	25A:AC-53b:4-5:175	38A:AC-53b:4-5:355	45A: AC-53b: 4-5: 175
Number of starts per hour @ 40°C/50°C/60°C	50/35/20	40/20/10	30/25/20
Minimum load current	500mA	500mA	500mA

## General Specifications

Pollution Degree	3
Weight	800g (approx.)
Degree of protection	IP20 (IEC 60 529)
Relative humidity	<95% non-condensing
Ramp up time	1...20s
Ramp down time	1...20s
Initial torque	0...70%
Kickstart	0...300ms
Status indicator LEDs:	
Power supply ON	LED, green (continuous)
Ramping	LED, yellow (intermittent)
Bypass relay ON	LED, yellow (continuous)
Over-temperature alarm	
Device alarm	LED, red (intermittent)
Motor PTC alarm	LED, red (continuous)
Wrong phase sequence*	LED, red (intermittent)
Phase loss	
Phase loss alarm*	LED, red (blinking at 4Hz)
Under voltage alarm	LED, red (blinking at 1.3Hz)
Function Parameters (ramp up etc.)	LED, yellow
Bargraph (1...10)	LED, red
Motor PTC alarm input P1, P2	Acc. to DIN 44081 and DIN 44082-1
Form designation	Form 1
Auxiliary relays:	
Bypass relay activation	Normally open (21,22)
Over-temperature, phase sequence phase loss alarm	Normally closed (11, 22)
Auxiliary relay contact capacity	3 A, 250 VAC 3 A, 30 VDC
Installation altitude	Above 1000m derate linearly by 1% of unit FLC per 100m to a maximum altitude of 2000m

\* detection of these alarm conditions is made during power-up of the device

## Conductor Data

<b>Line conductors:</b> <b>L1, L2, L3/T1, T2, T3</b>	
according to IEC 60947	0.75...16mm <sup>2</sup>
maximum size	
solid	1.5...16mm <sup>2</sup>
finely stranded with end sleeve	1.5...16mm <sup>2</sup>
stranded	1.5...25mm <sup>2</sup>
UL rated data	AWG 14...4
CSA rated data	AWG 10...6
Terminal screws	6xM5 (cage clamp)
Tightening torque	1.5...2.5 Nm /13...22 lb.in
CSA data	max. 3.0 Nm/ 26.5 lb. in
Stripping length	10 mm
<b>Secondary conductors:</b> <b>A1, A2, 11, 21, 22, P1, P2</b>	
according to IEC 60947	0.75...2.5mm <sup>2</sup>
maximum size	0.5...2.5mm <sup>2</sup>
UL/CSA rated data	AWG 22...14
Terminal screws	7xM3 (cage clamp)
Tightening torque	0.3...0.5 Nm/2.7...4.5 lb.in
Stripping length	6 mm

## Thermal Specifications

Operating temperature	-20° to +60°C (-4° to +140°F)
Storage temperature	-50° to +85°C (-58° to +185°F)

## Standards

Approvals	UL, cUL, CSA
Markings	CE
Norms	IEC/EN 60947-4-2

## Recommended Protection according to IEC/EN 60 947-4-2

	RSHP..25.V21	RSHP ..38.V21	RSHP..45.V21
Type of coordination: 2 Semiconductor fuse	Ferraz Shawmut 63A, Class URQ, Art.No. 6.621 CP URQ27x60/63	Ferraz Shawmut 80A, Class URQ, Art.No. 6.621 CP URQ27x60/80	Ferraz Shawmut 100A, Class URQ, Art.No. 6.621 CP URQ27x60/100
Type of coordination: 1 Motor protection circuit breaker	ABB: MS325 -25 Telemecanique: GV2-M22 Sprecher+Schuh: KTA3-25-25A	ABB: MS450 -40 Telemecanique: GV3-ME40 Sprecher+Schuh: KTA3-100-40A	ABB: MS450 -45 Telemecanique: GV3-ME63 Sprecher+Schuh: KTA3-100-63A
RK5 fuse	TRS45R 45A	TRS70R 70A	TRS90R 90A

## Wiring Diagram

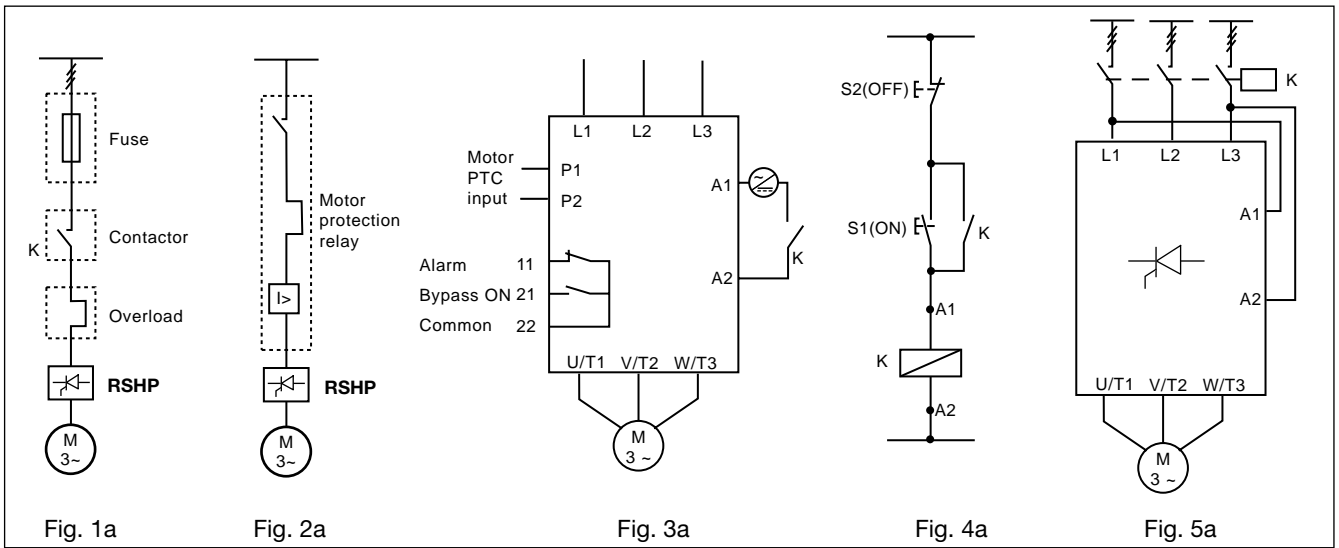

IEC

The motor controller provides by-passing of the semiconductors during running operation. Therefore the semiconductors can only be damaged by short-circuit currents during ramp-up and ramp-down. Please note that the motor controller does not isolate the motor from the mains.

**Figure 1: Protection of the device when using fuses.** Protection with semiconductor fuses is intended to protect the motor feeder and motor controller from damage due to short-circuit.

**Figure 2: Protection using a thermal-magnetic motor protection relay.** The motor feeder is protected but damage to the motor controller is possible. When motor failure occurs, if part of the motor winding limits the fault current and the motor feeder is protected, this type of protection can be considered acceptable.

**Figure 3: Secondary conductors.** 3.1: Control using a 2-position switch. When K is closed, the control

input is supplied to A1, A2 and soft starting of the motor is performed. When K is opened, soft stopping is performed. 3.2: Motor PTC input. When the motor PTC sensor is connected to P1, P2 the motor controller detects overheating of the motor windings. 3.3: Auxiliary Relays. The Alarm relay 11, 22 (NC) can be connected in series with the supply to the coil of a mains contactor. The Bypass ON relay 21, 22 (NO) can be used in series with the supply to the coil of an external

bypass contactor. **Figure 4: Control using ON and OFF push buttons** Pushing S1 soft starts the RSHP. Pushing S2 soft stops the RSHP. K is an auxiliary relay contact of the mains contactor. **Figure 5: Control using 2 phases** Connecting input A1, A2 to two of the incoming lines will soft start the motor when K is operated. When K is switched off, the motor will stop (no soft stop).

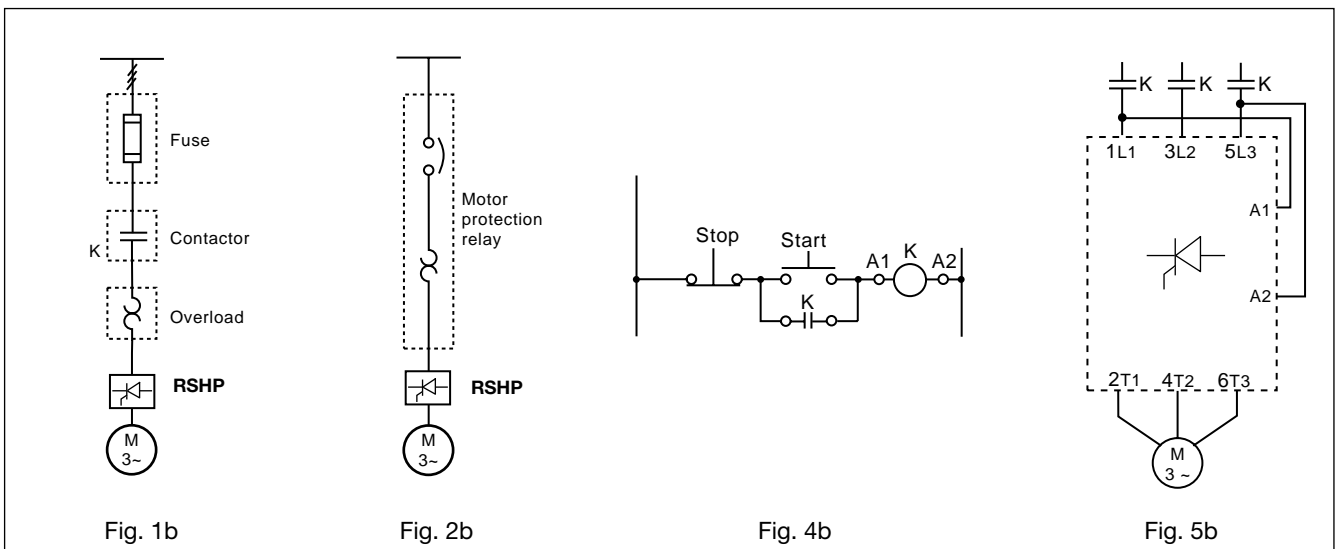

NEMA

## Dimensions

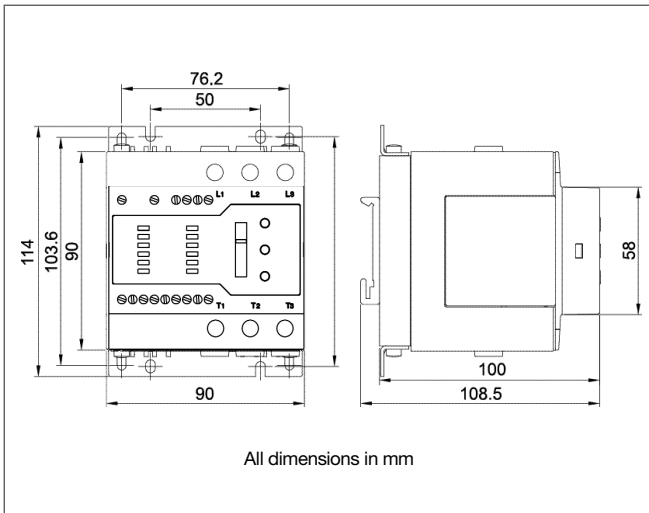

## Terminal Diagram

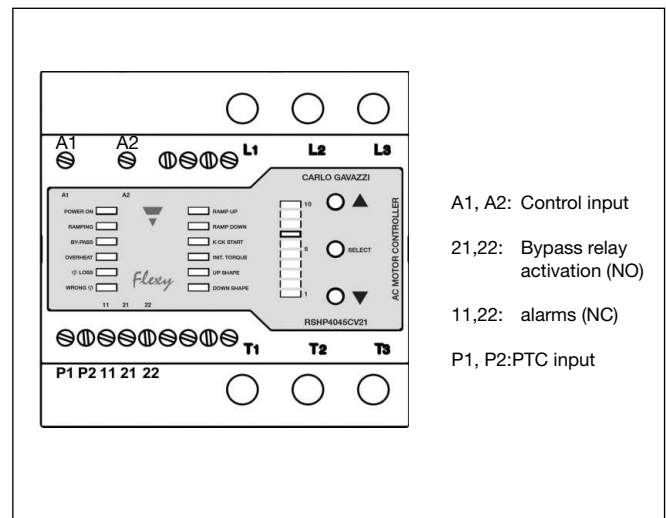

## Operation Diagram

Multi ramp starting strategies suitable for all applications are designed into the RSHP

Excluding setup position [9]

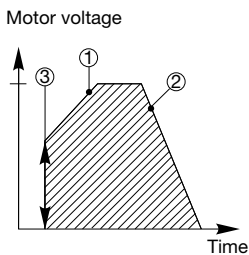

Setup position [9]

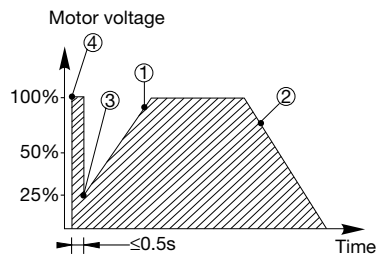

- ① Ramp-up time: time from zero load voltage to full load voltage.
- ② Ramp-down time: time from full load voltage to zero load voltage.
- ③ Initial voltage: voltage at the start of the ramp-up function.
- ④ Kickstart: constant initial voltage delay before ramp-up.

Table 1: Level 1 Parameters

Bargraph LED pos.	Selection switch	Ramp-up time s	Initial voltage	Ramp-down time s
1	Default: Standard	05	30%	10
2	Pump	05	40%	15
3	Light conveyor	02	40%	10
4	Heavy conveyor	15	60%	10
5	Low inertia fan	10	30%	00
6	High inertia fan	15	50%	00
7	Piston compressor	01	50%	00
8	Screw compressor	10	40%	00
9	Kick-start	05	50%	15
10*	High Torque	05	60%	05

\* These settings can be changed

# Operation Diagrams for RSHP

**Diagram 1: Normal Operation**

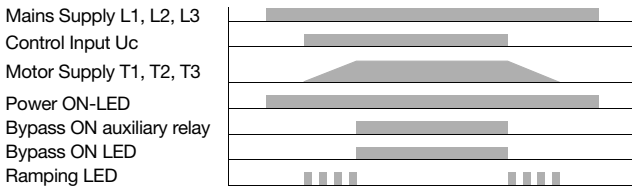

**Diagram 2a: Device over-temperature alarm**

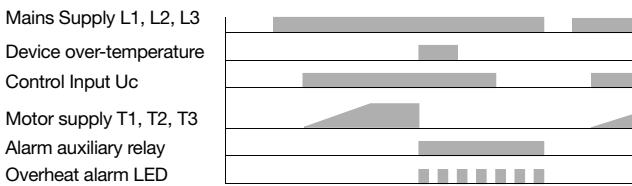

**Diagram 2b: Motor PTC alarm**

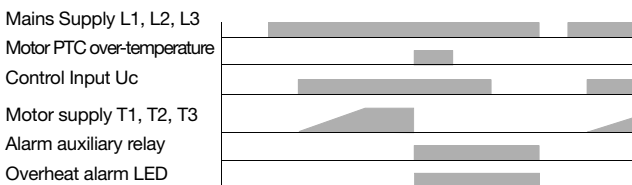

**Diagram 2c: Phase loss during power up**

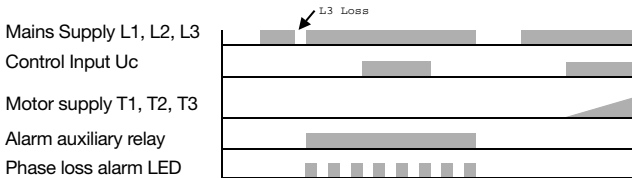

**Notes**

Note 1: After activation of the by-pass relay, there is a delay of 1 sec, during which removal of the control input will not initiate the ramp-down function.

Note 2: Cycling of the control input should be limited to a rate not exceeding 3 seconds ON and 3 seconds OFF. At faster cycling times, it is not guaranteed that the output of the unit will respond to the given input.

Important: The number of starts per hour and Overload Cycle values should always be taken into consideration when cycling is used.

Note 3: A phase loss on L1 or L2 causes the device to reset as these phases provide the internal power supply.

**Diagram 2d: Phase loss during ramping**

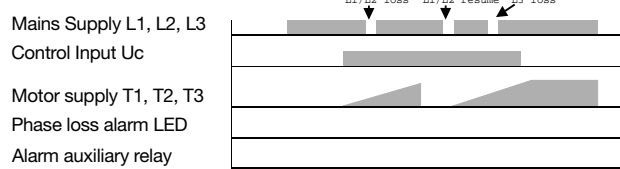

**Diagram 2e: Phase loss while bypass is ON**

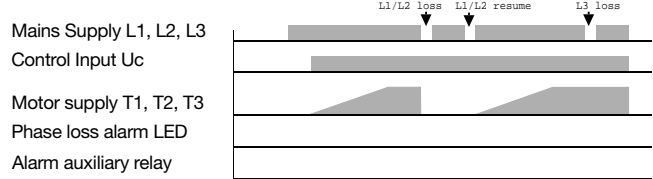

**Diagram 2f: Phase loss while bypass is being activated**

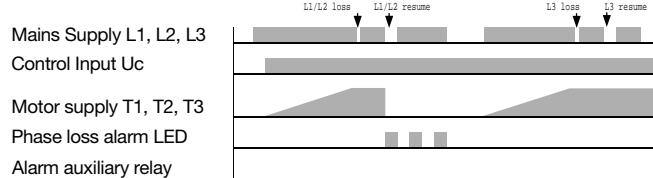

**Diagram 2g : Wrong phase sequence alarm**

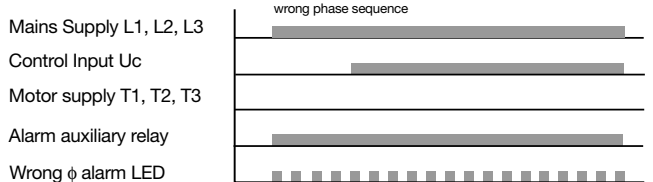

Note 4: Phase sequence and phase loss alarms are only detected if they occur during power up, when L1, L2, L3 are switched ON.

Note 5: When a motor PTC is connected, electromagnetic noise may be conducted into the unit. Thus if abnormal function is observed, the use of ferrite beads on the PTC wire (at the unit end) is recommended.

Note 6: Repetitive voltage dips on phase L1 and/or L2 during operation may lead to overheating of the motor. In case the by-pass relays are activated and the repetition rate of these dips is such that the internal supply voltage falls below a preset limit, the by-pass relays will be automatically switched off. This state is indicated by blinking of the phase loss led at 1.3Hz. Reset of the supply L1, L2 and L3 is necessary to resume normal function.

## Ramp setting procedure

### Factory DEFAULT - Plug and Play

The ramp selector is set to bargraph position 1, according to Table 1: "Level 1 Parameters". The product will be shipped with this standard ramp setting. If this setting is considered suitable, no other settings are required.

### Level 1 - FACTORY PRE-DEFINED RAMP PARAMETERS

For this mode, the 3-phases L1,L2,L3 must be present but control A1,A2 must not be present. In this level, the user may select from 10 pre-defined ramps by selecting one of the 10 bargraph positions: 1,2,3.....9 or 10, according to Table 1: "Level 1 Parameters". Position 1 is the same as the factory DEFAULT described above. In each pre-defined ramp, the values for all parameters (ramp up, ramp down, initial torque, kickstart, ramp up shape and ramp down shape) are fixed by the factory against each bargraph LED position. Position 10 is factory set for "High Torque Load" (see Table 1) but can be re-programmed according to Level 2 instructions. The bargraph LED will remain ON at the selected position during operation as long as L1,L2,L3 are present, to show which ramp parameters are being used.

#### To enter Level 1 mode:

Press SELECT once. One bargraph LED will start flashing at the position that has been previously programmed (position 1 if the product is just out of the box).

### To select the factory pre-defined ramp:

Use the UP and DOWN arrow buttons to move the flashing LED up or down on the bargraph.

### To save and exit Level 1 mode:

To fix the new settings, press SELECT. This stores the selected ramp position and causes the device to exit Level 1. The bargraph LED remains ON at the selected position during operation as long as L1,L2,L3 are present. (If no button is pressed for several seconds, the device goes out of this setting mode automatically and above steps must be repeated).

### Level 2 - RAMP CUSTOMISATION

In this level, a new combination of parameters settings (ramp up, ramp down, initial torque, kickstart, ramp up shape and ramp down shape) can be made that is not included in the pre-defined ramps of Level 1 (In Level 1 these settings have been fixed by the factory. See Table 1: Level 1 Parameters). In Level 2, each parameter of "position 10" can be re-defined individually by first selecting the parameter and then setting the bargraph level in accordance with Table 2: "Level 2 Parameters".

#### To enter Level 2 mode:

Press SELECT and move flashing bargraph LED to position 10. With the bargraph flashing at position 10, press and hold SELECT until the parameter LEDs scroll down

twice. The Ramp Up LED will light up. Press SELECT and one bargraph LED will start flashing. Position 10 parameters can now be redefined.

### To re-define position 10 parameters:

The Ramp up parameter LED must be flashing. The bargraph LED must be flashing at the position that has been previously programmed (position 7 if the product is just out of the box). Use the UP/DOWN arrow keys to move the flashing bargraph LED to the required position according to Table 2: "Level 2 Parameters" and then press SELECT. The next parameter LED (Ramp down) will start flashing to indicate that it can be adjusted.

The bargraph LED will also start flashing at the position that has been previously programmed (position 7 if the product is just out of the box). Use the arrow keys to move the flashing bargraph LED to the required position according to Table 2: "Level 2 Parameters" and then press SELECT. These steps are repeated until all parameters have been set. Ramp shapes can be selected in the same

way.

### To save and exit Level 2 mode:

To save and exit Level 2 selection procedure, press and hold SELECT until the parameter LEDs scroll down twice.

### Running with the customised ramp:

After Level 2 procedure has been completed the device will store the parameters in position 10. The bargraph LED in position 10 will light up continuously during operation.

#### Defaults:

Enter Level 2 mode as previously described. When the bargraph LED is flashing, press and hold the UP and DOWN arrow buttons simultaneously until the parameter LEDs scroll twice. This resets all the ramp settings to factory default.

#### Attention!

If no button is pressed for several seconds during Level 1 or Level 2 procedures, the product goes out of the Level setting mode back to the previous ramp parameter combination.

## Ramp Shapes

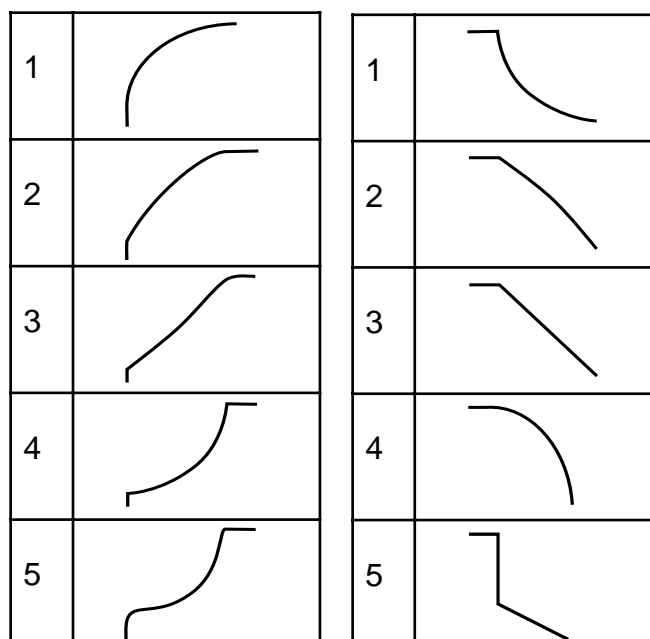

Table 2: Level 2 Parameters

Bargraph LED pos.	Ramp up times	Rampdown times	Initial voltage	Kickstart ms	Ramp up shape	Rampdown shape
1	0.5	0.5	0%	0	1	1
2	1	1	10%	20	2	2
3	1.5	1.5	20%	40	3	3
4	2	2	30%	60	4	4
5	3	3	40%	80	5	5
6	4	4	50%	100	-	-
7	5	5	60%	150	-	-
8	10	10	70%	200	-	-
9	15	15	-	250	-	-
10	20	20	-	300	-	-