

Switching Power Supply Redundant Module

Type SPD24RM20

DIN rail mounting

CARLO GAVAZZI



- Installation on DIN Rail 7.5 or 15mm
- 2 "Power Rdy" relay outputs
- Up to 480W output
- Unlimited number of connectable redundant power supplies
- Very compact dimensions
- UL, cUL listed
- TUV approved
- Ce and RoHS compliant

Product Description

This SPD additional module allows the connection of 1 power supply +1 or more additional redundant power supplies. In this case, the continuity of the 24VDC output is always guaranteed, even in case of failure of one power supply. 2 relay outputs provide voltage free outputs in order to send the alarm to a control unit when a failure occurs.

Ordering Key

SP D 24 RM 20

Model _____
 Mounting (D = Din rail) _____
 Output voltage _____
 Redundant module _____
 Maximum current _____

Approvals



Output Data

Output voltage drop	0.5V
Output maximum Current	20A
Output Peak Current >5ms	30A
Max Reverse Voltage	30V

Input Data

Rated input Voltage	21...28VDC
Number of inputs	2
Maximum input current	20A

Controls and Protections

Power RDY relay Output	
OK	input 20...30V ±5%
Fail	input 20...30V ±5%
Contact rating	1.0A

Approvals and EMC

Shock resistance	acc. to IEC 60068-2-27 (15G, 11ms, 3 Axis, 6 Faces, 3 times for each Face)
Vibration resistance	acc. to IEC 60068-2-6 (Mounting by rail: 10-500 Hz, 2G, along X, Y, Z each Axis, 60 min for each Axis)
UL / cUL	UL 508 Listed UL 60950-1 Recognized
TUV	EN 60950-1, CB scheme
CE	EN 55022 Class B, EN 55024, EN 61000-4-2, EN 61000-4-3, EN 61000-4-4, EN 61000-4-6, EN 61000-4-8, EN 61204-3

General Data

Insulation Voltage	
Input / Relay contact	100VDC
Insulation Resistance	
Input / Relay contact @100VDC	100MΩ
Operating temperature	-25°C...+71°C
Storage temperature	-25°C...+85°C
Relative Humidity	20...95%RH
MTBF (Bellcore issue 6 @ 40°C, GB)	659,000h
Cooling	Free air convection
Case material	Plastic
Dimensions L x W x D	90 x 54 x 114mm
Weight	210g

Mechanical Drawings mm (inches)

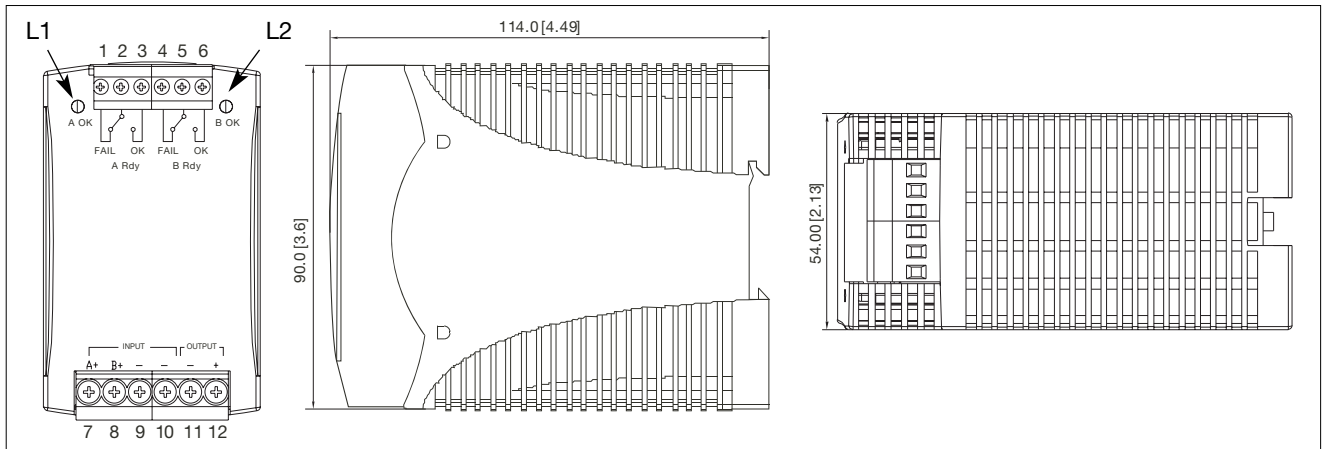

Pin Assignment and Front Controls

Pin No.	Designation	Description
1	A Rdy Fail	Relay normally closed contact (power supply A Fail)
2	A Rdy COM	Relay common contact
3	A Rdy OK	Relay normally open contact (power supply A OK)
4	B Rdy Fail	Relay normally closed contact (power supply B Fail)
5	B Rdy COM	Relay common contact
6	B Rdy OK	Relay normally open contact (power supply B OK)
7	Input A+	Positive Input power supply A
8	Input B+	Positive Input power supply B
9	Input -	Negative Input power supply A
10	Input -	Negative Input power supply B
11	Output -	Positive Output terminal
12	Output +	Negative Output terminal
L1	A OK	"A" power supply operation OK LED
L2	B OK	"B" power supply operation OK LED

Typical Application Notes

1.) 1+1 Redundancy: Using 1 more PS as the redundant unit.

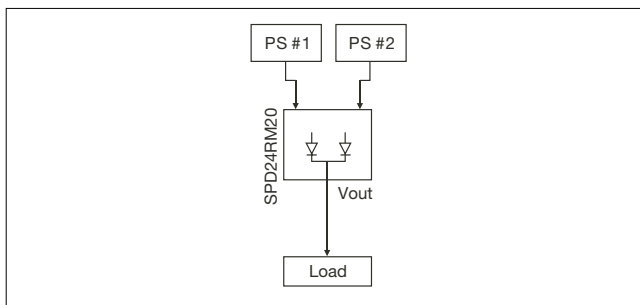

2.) Single Use: Connecting only one PS to one SPD24RM20 to reduce the stress of the diodes and hence increase the reliability.

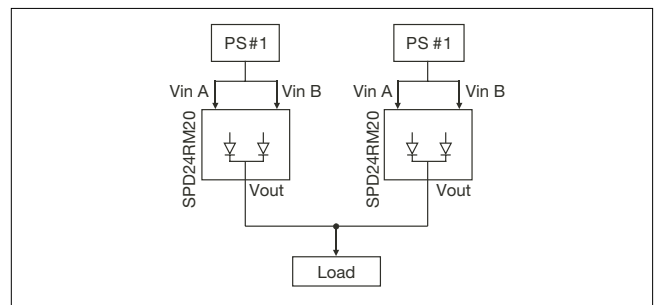

3.) 1+N Redundancy: Using more than one PS as redundant units to increase the reliability.

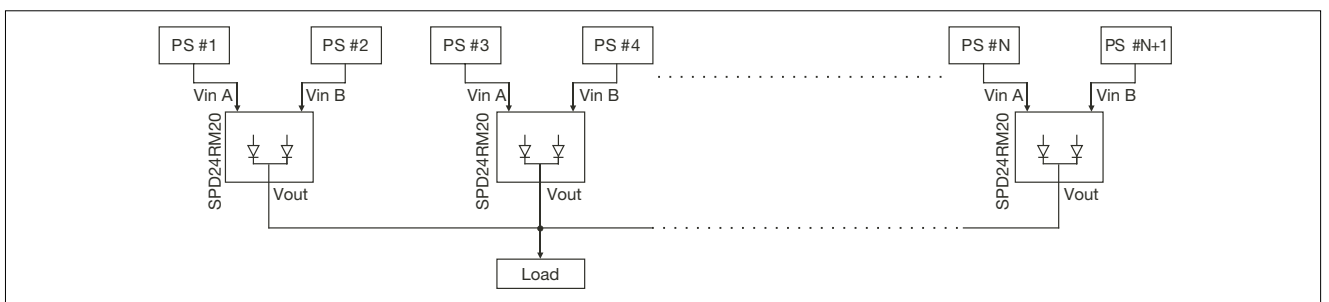



Circuit Diagram

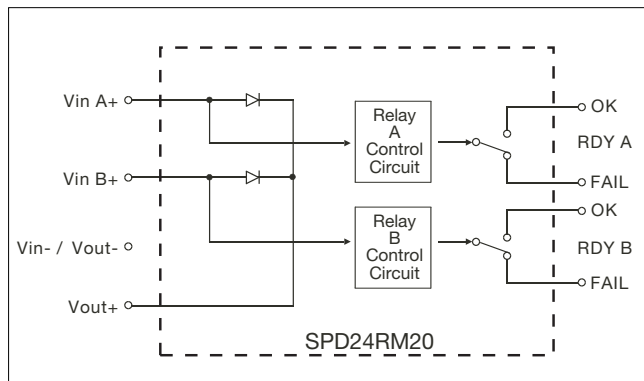

Installation

Ventilation and cooling	Normal convection All sides 25mm free space for cooling is recommended
Screw terminals	10-24AWG flexible or solid cable 8mm stripping recommend
Max. torque for screws terminals	
Input terminals	1.008Nm (9.0lb-in)
Output terminals	0.616Nm (5.5lb-in)
Plug-in connectors	10-24AWG flexible or solid cable 7mm stripping recommend
Max. torque for plug-in terminals	
Input terminals	0.784Nm (7.0lb-in)
Output terminals	0.784Nm (7.0lb-in)