

# Switching Power Supply Type SPD 120W 3 phases DIN rail mounting

CARLO GAVAZZI



- Universal AC 3 phases input full range
- Can also be used as single phase 480VAC
- Installation on DIN rail 7.5 or 15mm
- PFC as standard
- High efficiency up to 88%
- Power ready output
- Compact dimensions
- UL, cUL listed and TUV/CE

## Product Description

The Switching power supplies SPD series are specially designed to be used in all automation application where the installation is on a DIN rail and compact dimensions and performance are a must.

## Ordering Key

**SP D 24 120 3**

Model \_\_\_\_\_  
 Mounting ( D = Din rail ) \_\_\_\_\_  
 Output voltage \_\_\_\_\_  
 Output power \_\_\_\_\_  
 Input Type \_\_\_\_\_

Input type: 3 = three phase  
 (or single phase 400/500VAC<sup>3)</sup>)

## Approvals



## Output performances

Model	Rated output Voltage (VDC)	Output Power (W)	Output Current (A) <sup>1)</sup>	Voltage Trim Range		DC OK Threshold at startup (VDC)		DC low LED Threshold after startup(VDC)		Typical Efficiency
				Min. VDC	Max. VDC	Min.	Max.	Min.	Max.	
SPD12	12	120	10 (7.5)	11.4	14.5	10.0	11.2	10.0	11.2	87%
SPD24	24	120	5 (3.75)	22.5	28.5	17.6	19.4	17.6	19.4	88%

<sup>1)</sup> When powered with three phases input; with biphasic input value is in the brackets.

## Output data

Line regulation	± 1%	Temperature Coefficient	+0.02% / °C
Load regulation	± 1%	Hold up time Vi = 230VAC	20ms
Output Voltage accuracy	from 0 to +1% (factory adjusted)	Minimum load	0%
Ripple and Noise	100mV	Parallel Operation	NO

## Input data

Rated input voltage	400/500VAC	Frequency range	47- 63 Hz
Voltage range		Inrush current	10A
AC in	340 - 575VAC <sup>3)</sup>	P.F.C. Vi= 500VAC, Io nom.	0.6
DC in	480 - 820VDC		
Rated input current (380/500)	0.5A / 0.35A		

<sup>3)</sup> Biphasic or triphasic input (biphase can be: L1 L2, L2 L3 or L1 L3).  
 Note: when used as biphasic, the maximum output power is 75% of rated power.

## Controls and Protections

<b>Input Fuse</b>	1.0A/600VAC internal/phase <sup>4)</sup>	<b>Power ready output</b> (only SPD 24)	
<b>Overvoltage Protection</b> SPD12 SPD24	14.5 – 17.4VDC 30 – 33VDC	Threshold voltages Contact rating at 60VDC insulation	17.6 - 19.4VDC 0.3A 500VDC
<b>Output Short Circuit</b> Continuous	Current limit	<b>Overtemperature</b>	100 - 110°C (shutdown with auto-restart when temperature is back to normal)
<b>Rated Overload Protection</b>	115 - 135%		

<sup>4)</sup> Not replaceable by user.

## General data (@ nominal line, full load, 25°C )

<b>Ambient temperature</b>	-25°C to 71°C	<b>Cooling</b>	Free air convection
<b>Derating (&gt;61°C to +71°C)</b>	2.5%/°C	<b>MTBF (MIL-HDBK-217F)</b>	n.a.
<b>Ambient humidity</b>	20 - 95%RH	<b>Case material</b>	Metal (powder painted aluminium)
<b>Storage temperature</b>	-25°C to +85°C	<b>Weight</b>	800g / 28.22oz
<b>Dimensions L x W x D</b> Screw terminal type	123.6 x 74.3 x 112 mm 4.87 x 2.93 x 4.41 inches	<b>Protection degree</b>	IP20

## Approvals and EMC

<b>Insulation voltage I/O</b>	3.000VAC	<b>CE</b>	EN61000-6-3 EN55022 class B EN61000-3-2 EN61000-3-3 EN61000-6-2 EN55024
<b>Insulation resistance I/O</b> @ 500VDC	100MΩ		
<b>UL / cUL</b>	UL508 listed, UL60950-1, Recognized		
<b>TUV</b>	EN60950-1		

## Block diagrams

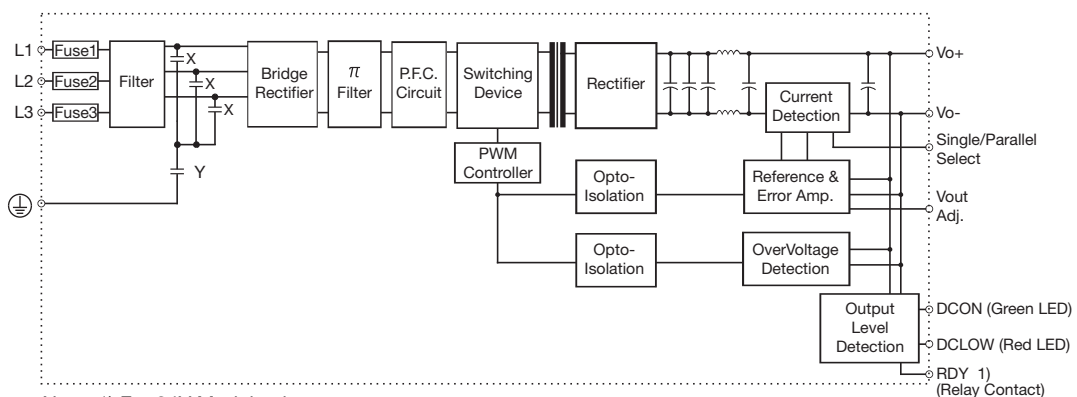

## Pin assignement and front controls

Pin No.	Designation	Description
1	V+	Positive output terminal
2	V+	Positive output terminal
3	V-	Negative output terminal
4	V-	Negative output terminal
5	GND	Ground terminal to minimise High frequency emissions
6	L1	Input terminals
7	L2	Input terminals
8	L3	Input terminals
9	RDY	A normal open relay contact for DC ON level control
10	RDY	A normal open relay contact for DC ON level control
	DC ON	DC output ready LED
	DC LO	DC low indicator LED
	Vout ADJ.	Trimmer for fine output voltage adjustment

## Installation

<b>Ventilation and cooling</b>	Normal convection All sides 25mm free space for cooling is recommended
<b>Screw connections</b>	10-24AWG flexible or solid cable 8mm stripping recommend
<b>Max. torque for screws terminals</b>	
Input terminals	1.008Nm (9.0lb-in)
Output terminals	0.616Nm (5.5lb-in)

## Derating Diagram

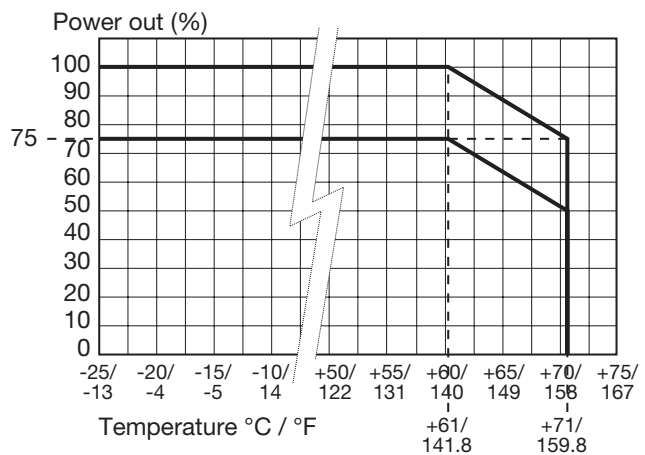

## Mechanical Drawings mm/inches

