

# Photoelectrics

## Retro-reflective, Polarized, Transistor Output

### Type PMP

CARLO GAVAZZI



- Range: 6 m
- Modulated, visible light, polarized
- Rated operational voltage: 10 to 40 VDC
- Output: 200 mA, NPN or PNP
- Make or break switching function (switch selectable)
- Fully protected
- LED-indication for target detected
- High immunity to ambient light
- 25 x 65 x 81 mm reinforced PC/ABS housing, IP 67
- Timer options (adjustable)

## Product Description

Retro-reflective photoelectric switch with polarized light. Range up to 6 m. Fixed sensitivity. High immunity to ambient light. Output function switch selectable. Protection degree IP 67. Screw terminal

connection. 25 x 65 x 81 mm polycarbonate housing. PG 13.5 or 1/2" NPT cable gland. Timer options: Delay on operate, delay on release, one shot (triggered on leading or trailing edge).

## Ordering Key

**PMP 6 P G T**

Type \_\_\_\_\_  
 Range \_\_\_\_\_  
 Output \_\_\_\_\_  
 Cable gland type \_\_\_\_\_  
 Timing function \_\_\_\_\_

## Type Selection

Housing W x H x D	Range S <sub>n</sub>	Ordering no. without timer NPN	Ordering no. without timer PNP	Ordering no. with timer NPN	Ordering no. with timer PNP
25 x 65 x 81 PG 13.5 cable gland 1/2" NPT cable gland	6 m 6 m	PMP 6N G PMP 6N I	PMP 6P G PMP 6P I	PMP 6N GT PMP 6N IT	PMP 6P GT PMP 6P IT

## Specifications

<b>Rated operating distance (S<sub>n</sub>)</b> (0 to 5,000 lux)	6 m With reflector type ER 4, ref. target	<b>Time delay before avail. (t<sub>v</sub>)</b>	≤ 300 ms (typ. 100 ms)
<b>Rated operational volt. (U<sub>B</sub>)</b>	10 to 40 VDC	<b>Output function</b>	Switch selectable, make or break switching
<b>Ripple (U<sub>rpp</sub>)</b>	10%	<b>Indication</b>	Target detected LED, yellow
<b>Output current</b> Continuous (I <sub>e</sub> ) Short-time (I)	≤ 200 mA 200 mA, max. load capacity 100 nF	<b>Optional timer</b>	Delay on operate 0.1 to 7 s ± 2 s Delay on release 0.1 to 7 s ± 2 s One shot 0.1 to 7 s ± 2 s
<b>No load supply current</b>	≤ 40 mA	<b>Environment</b>	Overvoltage category III (IEC 60664/60664A; 60947-1) Pollution degree 3 (IEC 60664/60664A; 60947-1) Degree of protection IP 67 (IEC 60529; 60947-1)
<b>OFF-state current (I<sub>r</sub>)</b>	Max. 100 μA	<b>Temperature</b>	Operating -25° to +55°C (-13° to +131°F) Storage -30° to +80°C (-22° to +176°F)
<b>Voltage drop (U<sub>d</sub>)</b>	≤ 2.5 VDC	<b>Vibration</b>	10 to 150 Hz, 0.5 mm/7.5 g (IEC 60068-2-6)
<b>Transient voltage</b>	IEC 60947-5-2, level 3, 2.5 kV	<b>Shock</b>	2 x 1 m & 100 x 0.5 m (IEC 60068-2-32)
<b>Dielectric voltage</b>	2000 VAC rms (cont./supply)	<b>Rated insulation voltage</b>	50 VAC (rms)
<b>Sensitivity</b>	Fixed	<b>Electrical protection</b>	Short-circuit, reverse polarity, overvoltage, transients
<b>Light source</b>	GaAlAs, LED, 660 nm		
<b>Light type</b>	Visible, modulated		
<b>Optical angle</b>	±2°		
<b>Light spot size</b>	280 mm at 4 m		
<b>Operating frequency</b>	100 Hz		
<b>Response time</b> OFF-ON (t <sub>ON</sub> ) ON-OFF (t <sub>OFF</sub> )	≤ 4 ms ≤ 6 ms		

## Specifications (cont.)

<b>Housing material</b>	
Body	PC/ABS, grey
Front	PC, red
Cover	PC, black
Cable gland	PA, black, reinforced
Mounting bracket	Steel, black
<b>Connection</b>	
Screw terminal	5 x 2 x 1 mm <sup>2</sup>
Cable gland	PG 13.5 or 1/2" NPT for cable 6 to 10 mm
<b>Weight</b>	90 g
<b>CE-marking</b>	Yes

## Connection Diagram

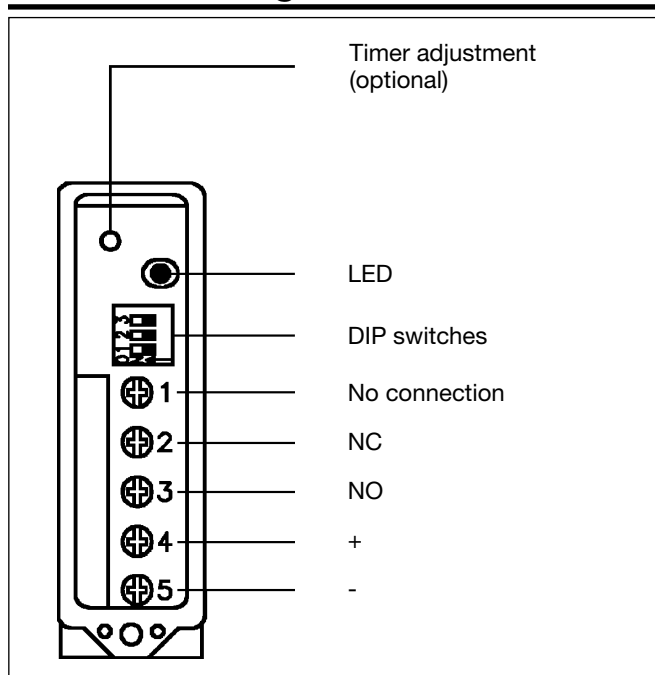

## Selection of Function

	Switch 1 2 3	
PMP ...		1 Break switching
		2 Make switching
PMP ...T		3 Delay on operate - Break switching
		4 Delay on operate - Make switching
		5 Delay on release - Break switching
		6 Delay on release - Make switching
		7 One shot, trailing edge - Break switching
		8 One shot, trailing edge - Make switching
		9 One shot, leading edge - Break switching
		10 One shot, leading edge - Make switching
		☒ Don't care
		Upper position ON (Mode 1) Lower position OFF (Mode 0)

## Truth Table

	Make switching		Break switching	
	Yes	No	Yes	No
Object present	Yes	No	Yes	No
LED	OFF	ON	OFF	ON
Load	Non-active	Active	Active	Non-active

## Accessories

- Reflectors: ER series
- MB02 mounting bracket 90 mm long for mounting PMP from behind

## Delivery Contents

- Photoelectric switch: PMP
- Cable gland
- Installation instruction
- Mounting bracket
- **Packaging:** Corrugated cardboard (environmentally friendly recycling material)

## Operation Diagram

t = Time delay  
tv = Power ON delay

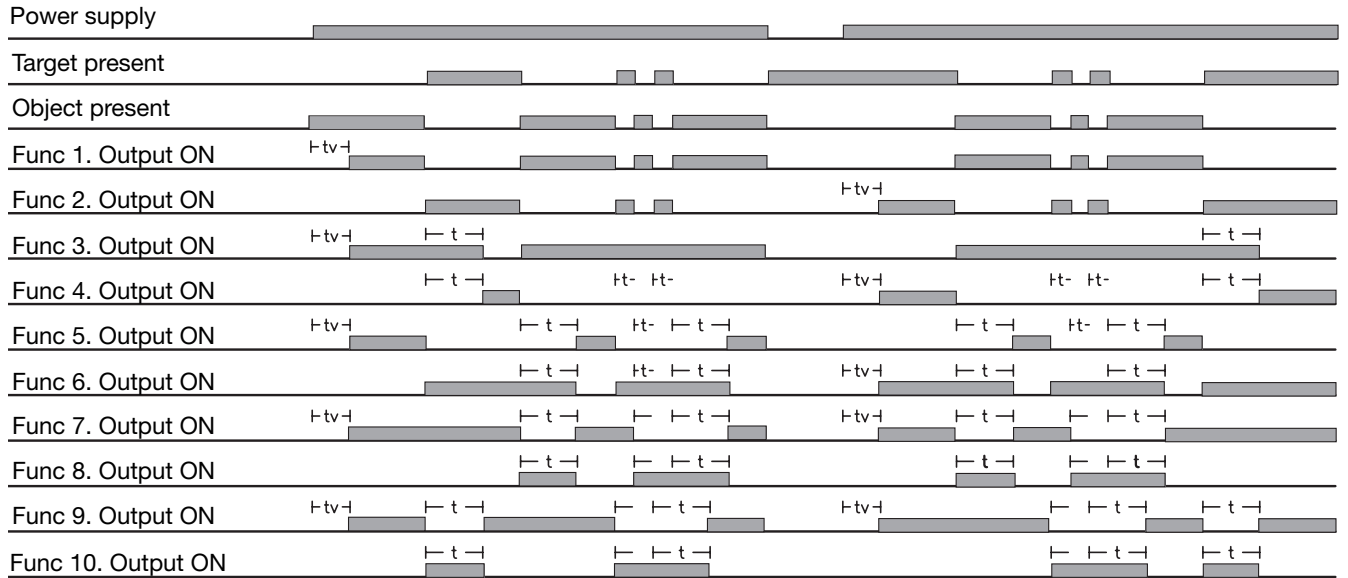

## Dimensions

