

# Photoelectrics

## Diffuse-reflective, Transistor Output

### Type PMD

CARLO GAVAZZI



- Range: 800 mm
- Modulated, infrared light
- Rated operational voltage: 10 to 40 VDC
- Output: 200 mA, NPN or PNP
- Make or break switching function (switch selectable)
- LED-indication for target detected
- 25 x 65 x 81 mm reinforced ABS housing, IP 67
- Timer options (adjustable)
- NO and NC output



## Product Description

Diffuse-reflective photoelectric switch. Range up to 800 mm. Adjustable sensitivity. Immune to ambient light. Output function switch selectable. Protection degree IP 67. Screw terminal connection.

25 x 65 x 81 mm plastic housing. PG 13.5 or 1/2" NPT cable gland. Timer options: Delay on operate, delay on release, one shot (triggered on leading or trailing edge).

## Ordering Key

**PMD 8 P G T**

Type \_\_\_\_\_  
 Range \_\_\_\_\_  
 Output \_\_\_\_\_  
 Cable gland type \_\_\_\_\_  
 Timing function \_\_\_\_\_

## Type Selection

Housing W x H x D	Range S <sub>n</sub>	Ordering no. without timer NPN	Ordering no. without timer PNP	Ordering no. with timer NPN	Ordering no. with timer PNP
25 x 65 x 81 PG 13.5 cable gland 1/2" NPT cable gland	800 mm 800 mm	PMD 8N G PMD 8N I	PMD 8P G PMD 8P I	PMD 8N GT PMD 8N IT	PMD 8P GT PMD 8P IT

## Specifications

<b>Rated operating distance (S<sub>n</sub>)</b> (0 to 5000 lux)	0.8 m, reference target Kodak test card R 27, white, 90% reflectivity, 200 x 200 mm	<b>Response time</b> OFF-ON (t <sub>ON</sub> ) ON-OFF (t <sub>OFF</sub> )	≤ 4 ms ≤ 6 ms
<b>Rated operational volt. (U<sub>B</sub>)</b>	10 to 40 VDC	<b>Time delay before avail. (t<sub>v</sub>)</b>	≤ 300 ms (typ. 100 ms)
<b>Ripple (U<sub>rpp</sub>)</b>	10%	<b>Output function</b>	switch selectable, make or break switching
<b>Output current</b> Continuous (I <sub>a</sub> ) Short-time (I)	≤ 200 mA 200 mA, max. load capacity 100 nF	<b>Indication</b> Target detected	LED, yellow
<b>No load supply current (I<sub>o</sub>)</b>	≤ 40 mA	<b>Optional timer</b> Delay on operate Delay on release One shot	0.1 to 7 s ± 2 s 0.1 to 7 s ± 2 s 0.1 to 7 s ± 2 s
<b>OFF-state current (I<sub>r</sub>)</b>	Max. 100 μA	<b>Environment</b> Installation category Pollution degree Degree of protection	III (IEC 60664/60664A; 60947-1) 3 (IEC 60664/60664A; 60947-1) IP 67 (IEC 60529; 60947-1)
<b>Voltage drop (U<sub>d</sub>)</b>	≤ 2.5 VDC	<b>Temperature</b> Operating Storage	-25° to +55°C (-13° to +131°F) -30° to +80°C (-22° to +176°F)
<b>Transient voltage</b>	IEC 947-5-2, level 3, 2.5 kV	<b>CE-marking</b>	Yes
<b>Dielectric voltage</b>	2000 VAC rms (cont./supply)		
<b>Sensing range (S<sub>d</sub>)</b>	0.2 - 0.8 m		
<b>Light source</b> <b>Light type</b> <b>Detection angle</b> (200 x 200 mm test card)	GaAlAs, LED, 880 nm infrared, modulated ±12°		
<b>Operating frequency</b>	100 Hz		



## Specifications (cont.)

<b>Vibration</b>	10 to 150 Hz, 0.5 mm/7.5 g (IEC 60068-2-6)
<b>Shock</b>	2 x 1 m & 100 x 0.5 m (IEC 60068-2-32)
<b>Rated insulation voltage</b>	50 VAC (rms)
<b>Housing material</b>	
Body	ABS, grey, reinforced
Front	SAN, black
Cover	PC, black
Cable gland	PA, black, reinforced
Mounting bracket	Steel, black
<b>Connection</b>	
Screw terminal	5 x 2 x 1 mm <sup>2</sup>
Cable gland	PG 13.5 or 1/2" NPT for cable 6 to 10 mm
<b>Weight</b>	90 g

## Connection Diagram

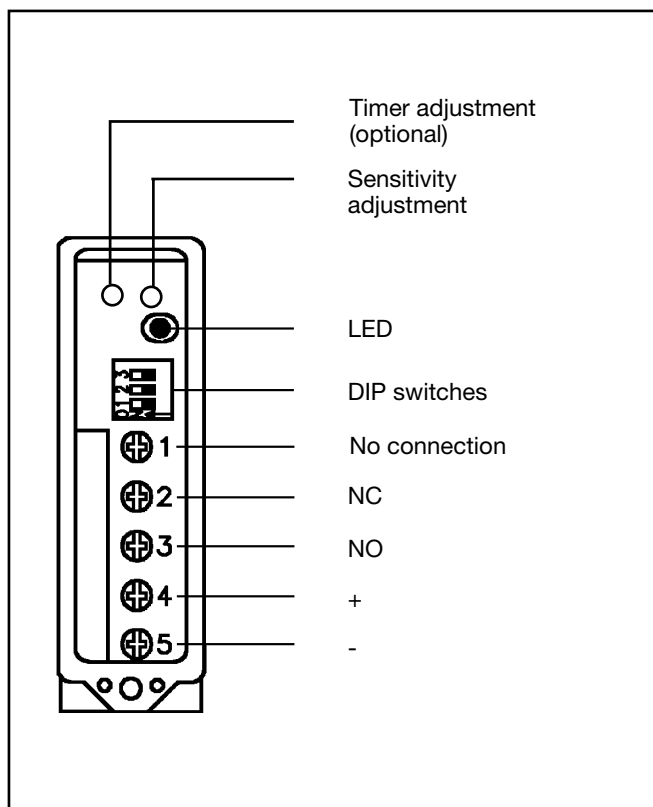

## Selection of Function

	Switch 1 2 3	
PMD 8 ..		1 Break switching
		2 Make switching
PMD 8 .. T		3 Delay on operate - Break switching
		4 Delay on operate - Make switching
		5 Delay on release - Break switching
		6 Delay on release - Make switching
		7 One shot, trailing edge - Break switching
		8 One shot, trailing edge - Make switching
		9 One shot, leading edge - Break switching
		10 One shot, leading edge - Make switching
		☒ Don't care
		Upper position ON (Mode 1) Lower position OFF (Mode 0)

## Reduction Factors

Reduction factors photoelectric switches	
<b>Note:</b> Real sensing distance = rated operating distance (S <sub>n</sub> ) x reduction factor	
Kodak test card, white, type R 27, 90% reflectivity	1.0
Dead black cardboard	0.1 - 0.4
Kodak test card, grey, type R 27	0.41 - 0.45
White Styropack	1.0 - 1.2
Bright metal	1.2 - 2.0
White cotton	0.5 - 0.8
Grey PVC	0.4 - 0.8
Raw wood	0.4 - 0.8
ER 1, reflector	0.3

## Truth Table

	Make switching		Break switching	
	No	Yes	No	Yes
Object present	No	Yes	No	Yes
LED	OFF	ON	OFF	ON
Load	Non-active	Active	Active	Non-active

## Delivery Contents

- Photoelectric switch: PMD
- Cable gland
- Installation instruction
- Mounting bracket
- **Packaging:** Corrugated cardboard  
(environmentally friendly recycling material)

## Operation Diagram

t = Time delay  
tv = Power ON delay

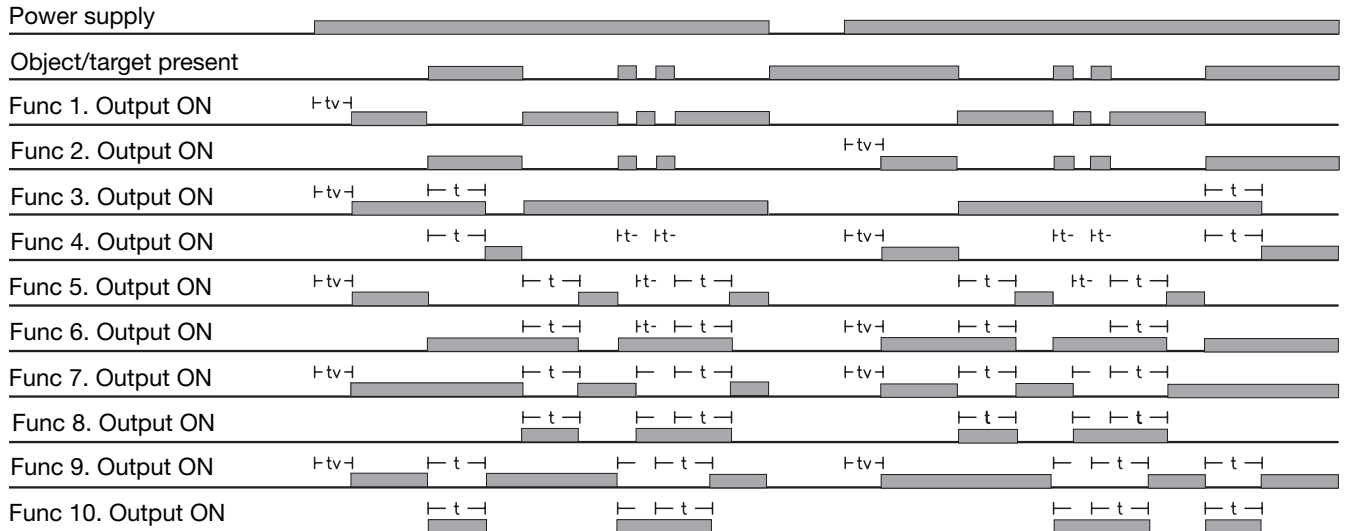

## Dimensions

