

THE INFORMATION CONTAINED HEREIN IS CONSIDERED "PROPRIETARY" TO BEL FUSE INC. AND SHALL NOT BE COPIED, REPRODUCED OR DISCLOSED WITHOUT THE WRITTEN APPROVAL OF BEL FUSE INC.

LED 2 & 4 POLARITY			LED 1 & 3 POLARITY		
PIN 11	PIN 12	COLOR	PIN 13	PIN 14	COLOR
+	-	GREEN	-	+	YELLOW
			+	-	GREEN

PRELIMINARY

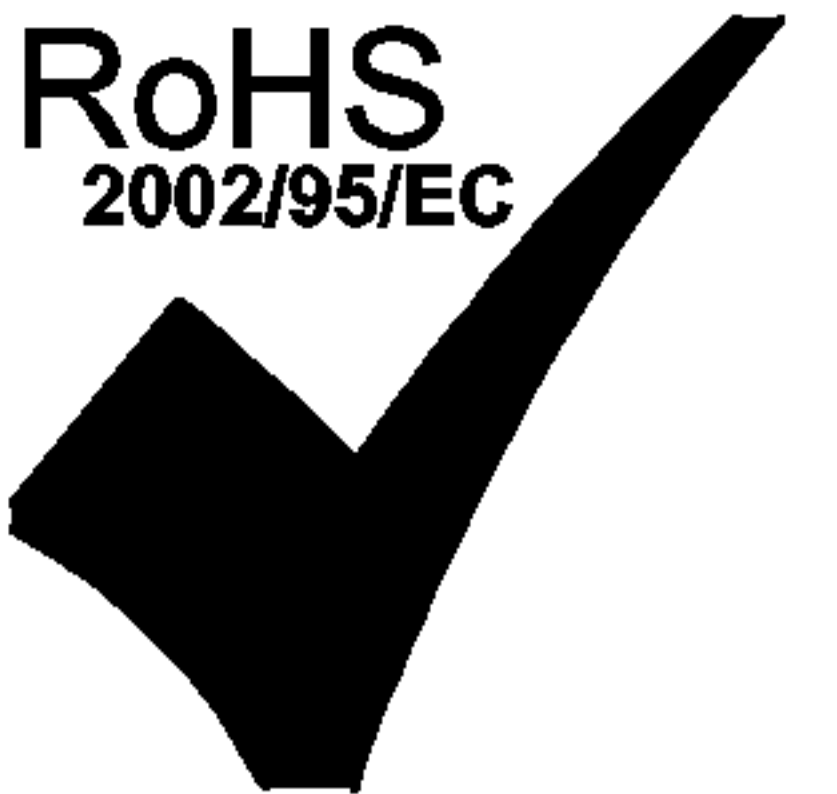

ELECTRICAL CHARACTERISTICS @ 25°C

TURNS RATIO

TP1	1CT : 1CT ±2%
TP2	1CT : 1CT ±2%
TP3	1CT : 1CT ±2%
TP4	1CT : 1CT ±2%

DCL @ 100kHz/100mVRMS

8mA DC BIAS 350µH MIN.

INS. LOSS

0.1MHz TO 1MHz	-1.1 dB MAX
1MHz TO 65MHz	-0.5 dB MAX
65MHz TO 100MHz	-0.8 dB MAX
100MHz TO 125MHz	-1.2 dB MAX

RET. LOSS (MIN)

0.5MHz-40MHz	-18 dB
40MHz-100MHz	-12+20LOG(f/80MHz) dB

CM TO CM REJ

100kHz - 100MHz -30 dB MIN

CM TO DM REJ

100kHz - 100MHz -35 dB MIN

HIPOT (Isolation Voltage):

1500 Vrms

100% OF PRODUCTION TESTED TO COMPLY WITH IEEE 802.3 ISOLATION REQUIREMENTS.

LEDS 2 & 4

VF (FORWARD VOLTAGE)	IF=20mA	GREEN	2.2V TYP.
λD (DOMINANT WAVELENGTH)	IF=20mA	GREEN	565nm TYP.

VF (FORWARD VOLTAGE)	IF=20mA	GREEN	2.2V TYP.
		YELLOW	2.1V TYP.
λD (DOMINANT WAVELENGTH)	IF=20mA	GREEN	565nm TYP.
		YELLOW	590nm TYP.

LED 2 & 4

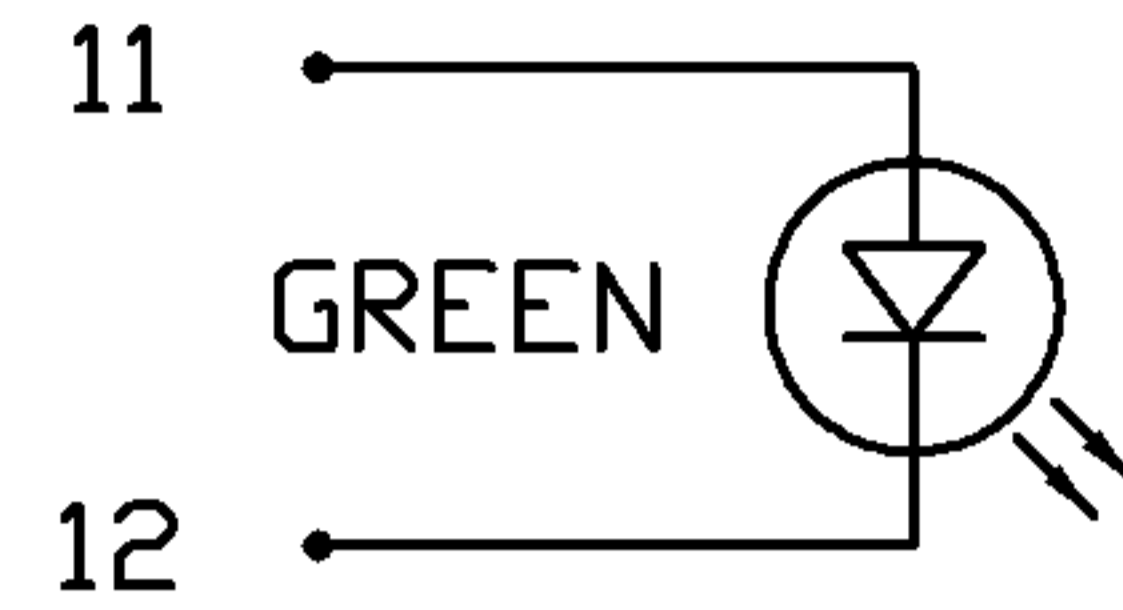

TRDCT1/2/3/4 9

LED 1 & 3

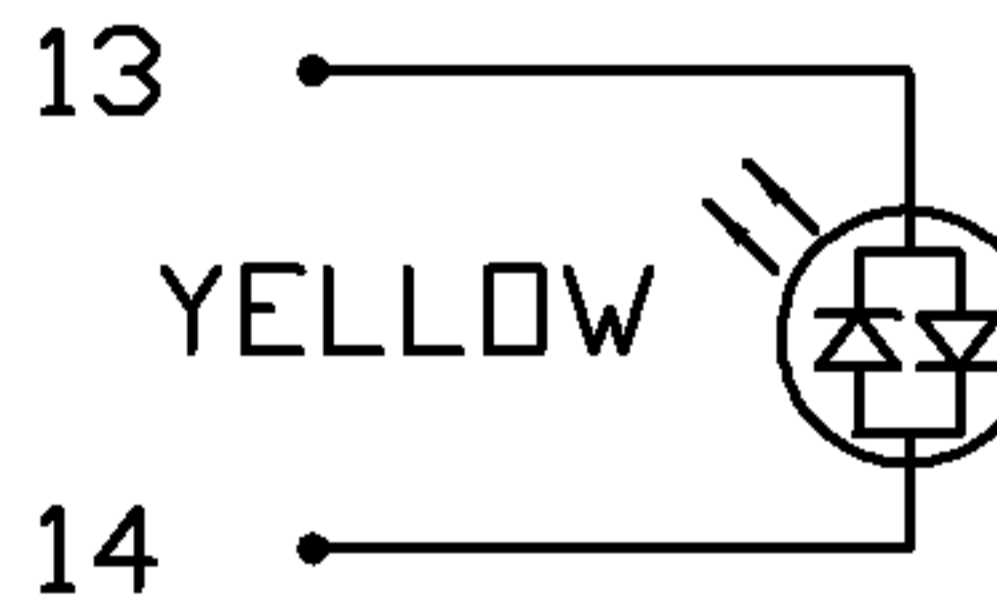

SCHEMATIC

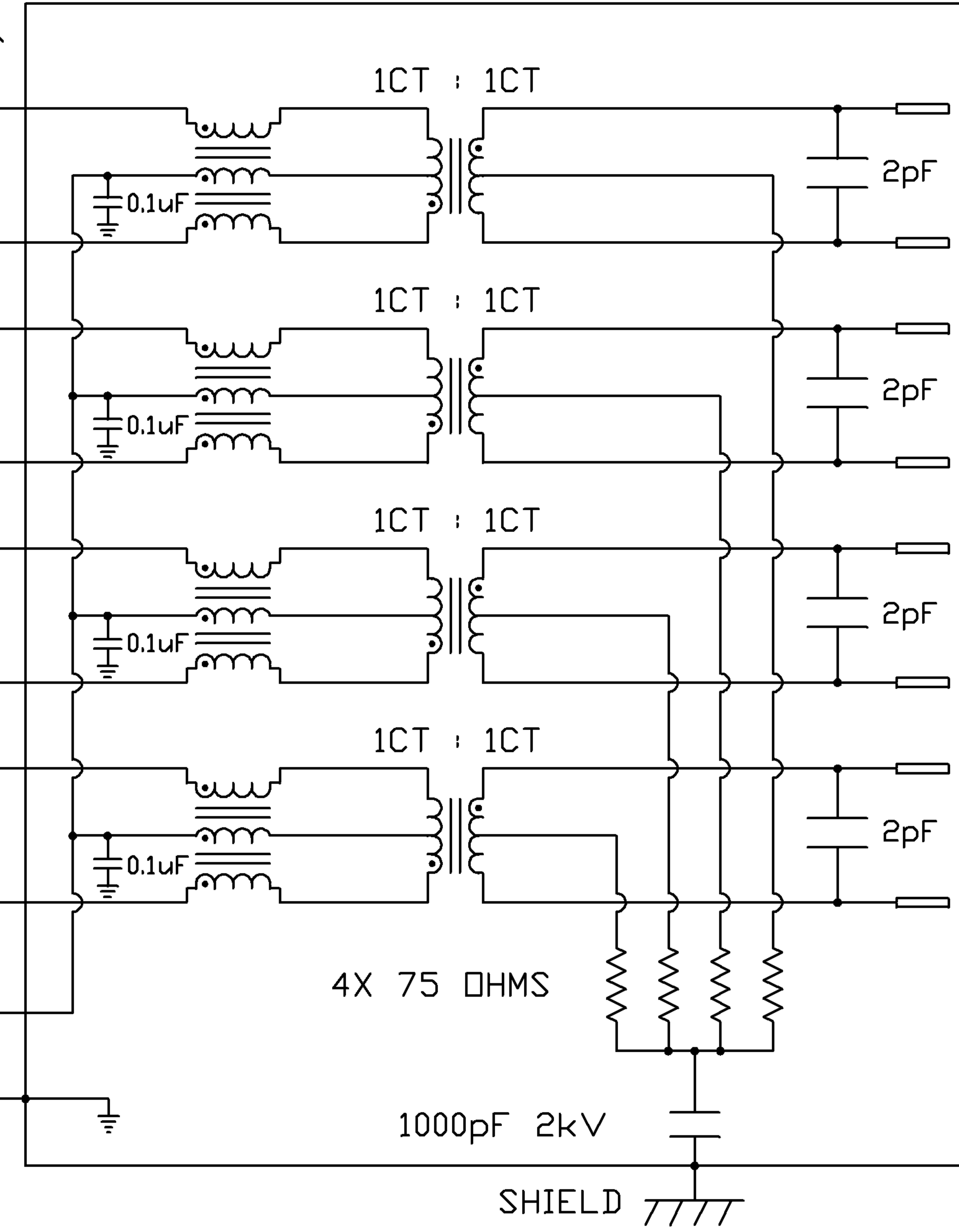

RJ45

- 1 TRP1+
- 2 TRP1-
- 3 TRP2+
- 6 TRP2-
- 4 TRP3+
- 5 TRP3-
- 7 TRP4+
- 8 TRP4-

ORIGINATED BY CHOW WANCHUNG	DATE 11-29-08	TITLE 2X1 gigabit MagJack® WITH UPPER AND LOWER LED (8 Cores)	PART NO. / DRAWING NO. 0879-2L1R-Y6	STANDARD DIM. TOL. IN INCH	[] METRIC DIM. AS REFERENCE		
DRAWN BY WEIDE LEE	DATE 11-29-08		FILE NAME 0879-2L1R-Y6_PB.DWG	.X .XX .XXX	UNIT : INCH [mm] SCALE : N/A	REV. : PB SIZE : A4 PAGE : 2	

THE INFORMATION CONTAINED HEREIN IS CONSIDERED "PROPRIETARY" TO BEL FUSE INC. AND SHALL NOT BE COPIED, REPRODUCED OR DISCLOSED WITHOUT THE WRITTEN APPROVAL OF BEL FUSE INC.

PRELIMINARY

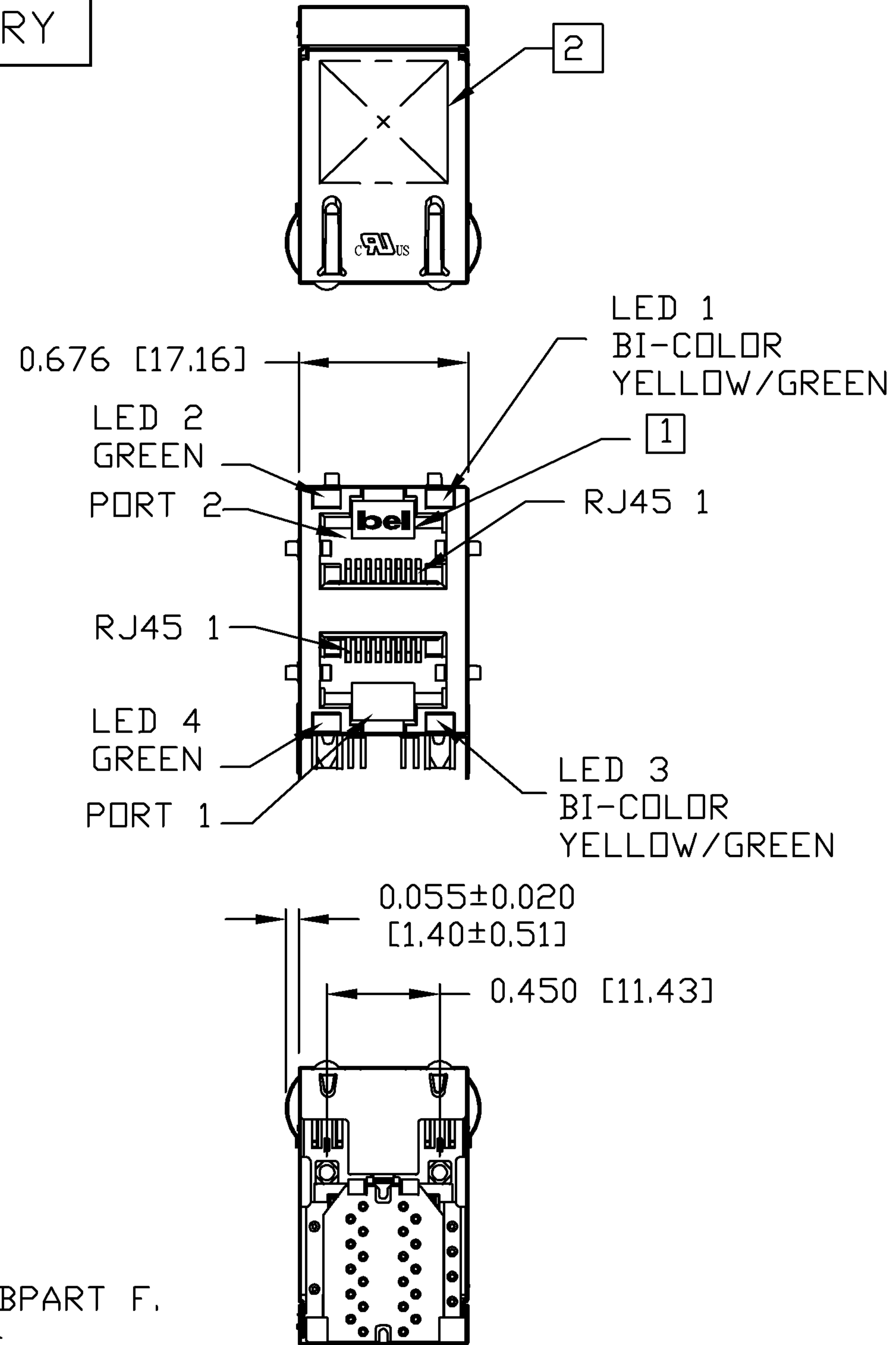
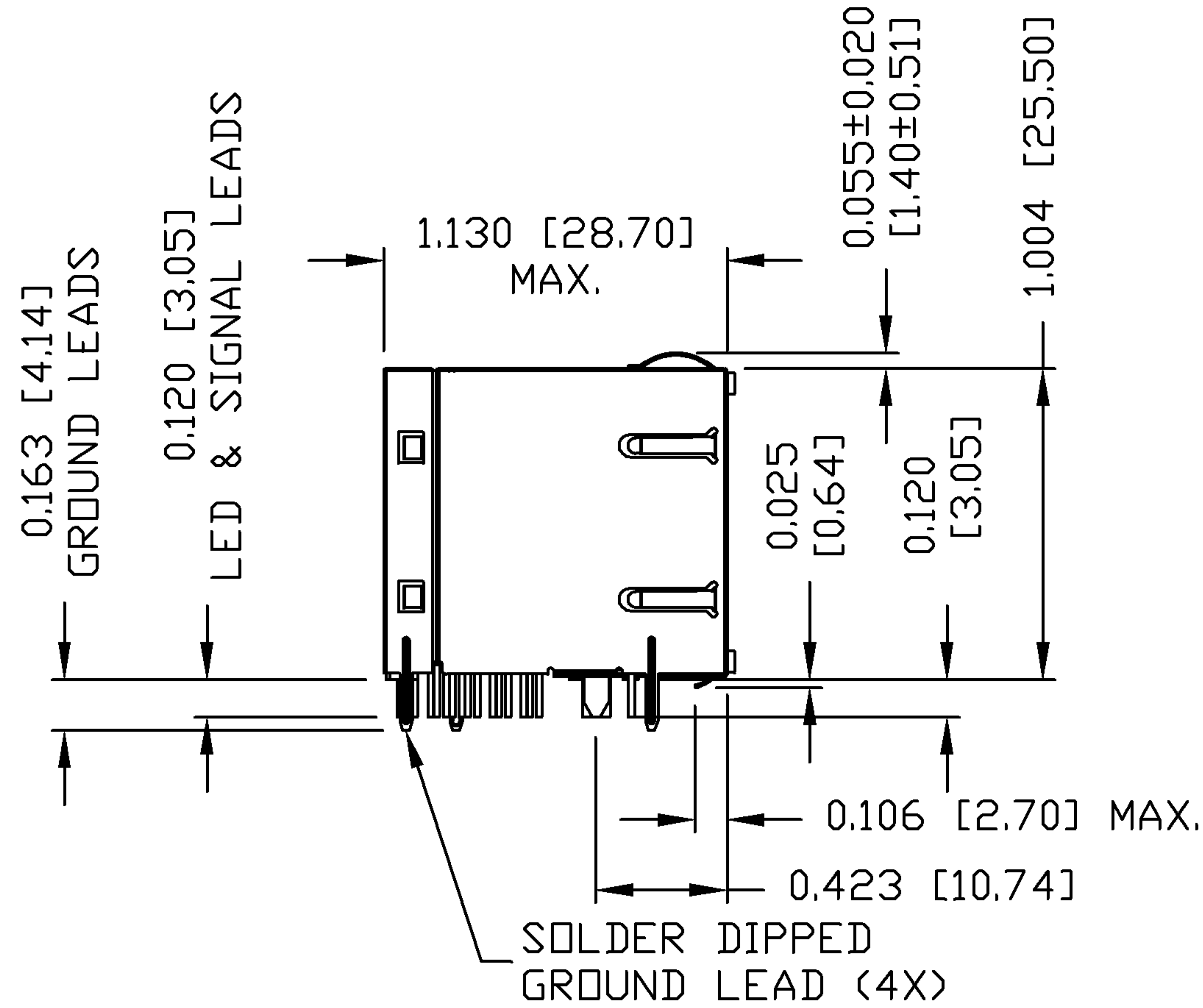

NOTES:

- PLASTIC HOUSING: THERMOPLASTIC PBT
FLAMMABILITY RATING UL 94V-0
- CONTACT PLATING: 50 MICRO-INCH HARD GOLD PLATING
- OUTPUT PINS: TIN-COATED COPPER WIRE, DIA 0.018 INCH.
- METAL SHIELD: NICKEL PLATED ON COPPER ALLOY.
(ALL GROUND LEADS ARE SOLDER DIPPED)

[1] JACK CAVITY CONFORMS TO FCC RULES AND REGULATIONS, PART 68 SUBPART F.

[2] MARK PART WITH MFG LOGO, MFG NAME, PART NUMBER, AND DATE CODE.

RoHS COMPLIANCE, PER EU DIRECTIVE 2002/95/EC.

UL RECOGNIZED - FILE #E196366 AND E169987.

ORIGINATED BY	DATE	TITLE 2X1 gigabit MagJack® WITH UPPER AND LOWER LED (8 Cores)	PART NO. / DRAWING NO.	STANDARD DIM.	[] METRIC DIM. AS REFERENCE		 COMPONENTS FOR A CONNECTED PLANET
DAVID CAO	11-29-08		0879-2L1R-Y6	TOL. IN INCH	UNIT : INCH [mm]	REV. : PB	
DRAWN BY	DATE		FILE NAME	.X	SCALE : N/A	SIZE : A4	
LU XUEPING	11-29-08	0879-2L1R-Y6_PB.DWG	.XX	±0.010	PAGE : 3		

THE INFORMATION CONTAINED HEREIN IS CONSIDERED "PROPRIETARY" TO BEL FUSE INC. AND SHALL NOT BE COPIED, REPRODUCED OR DISCLOSED WITHOUT THE WRITTEN APPROVAL OF BEL FUSE INC.

PRELIMINARY

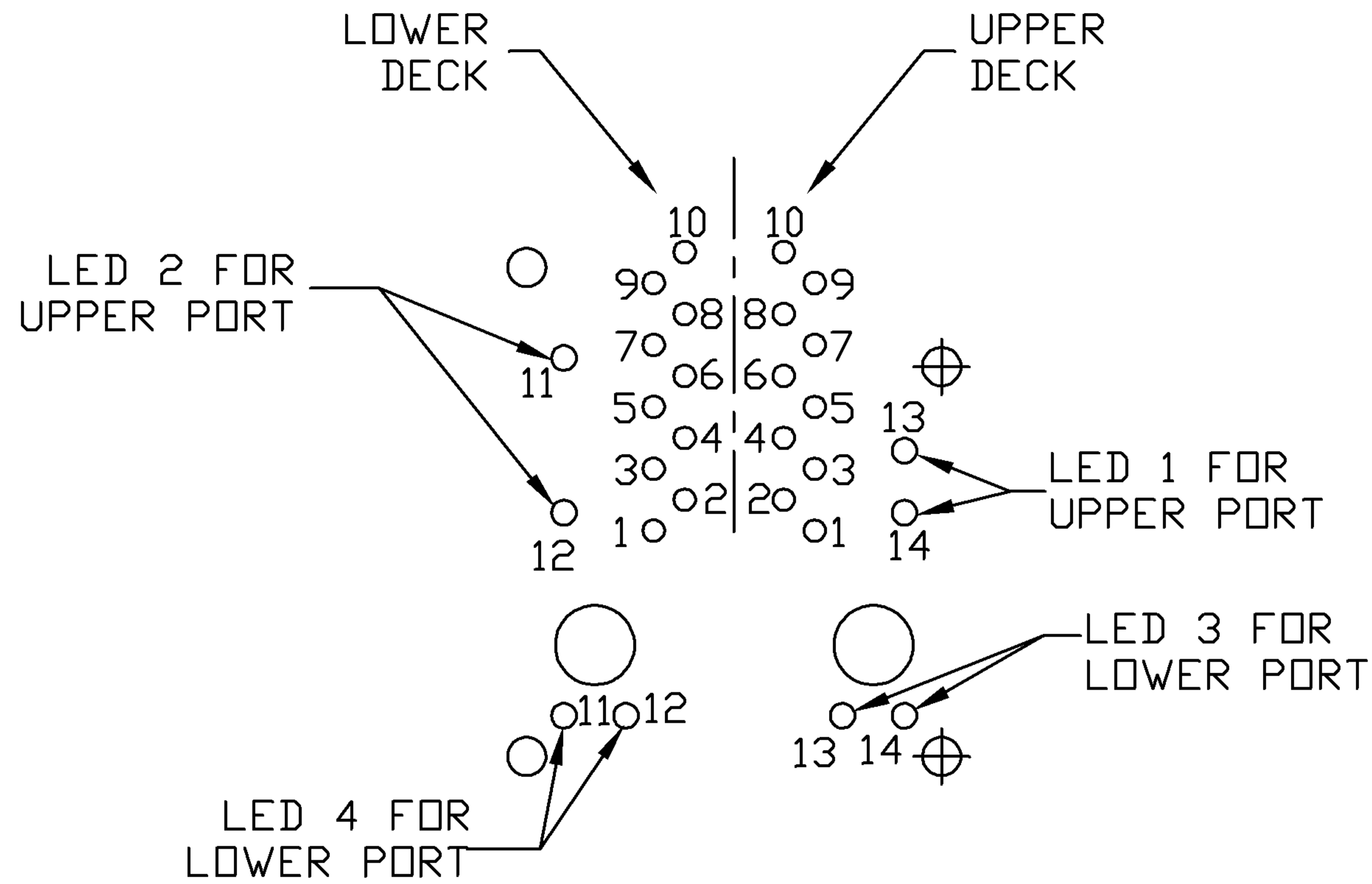

PORT ASSIGNMENT
(COMPONENT SIDE VIEW)

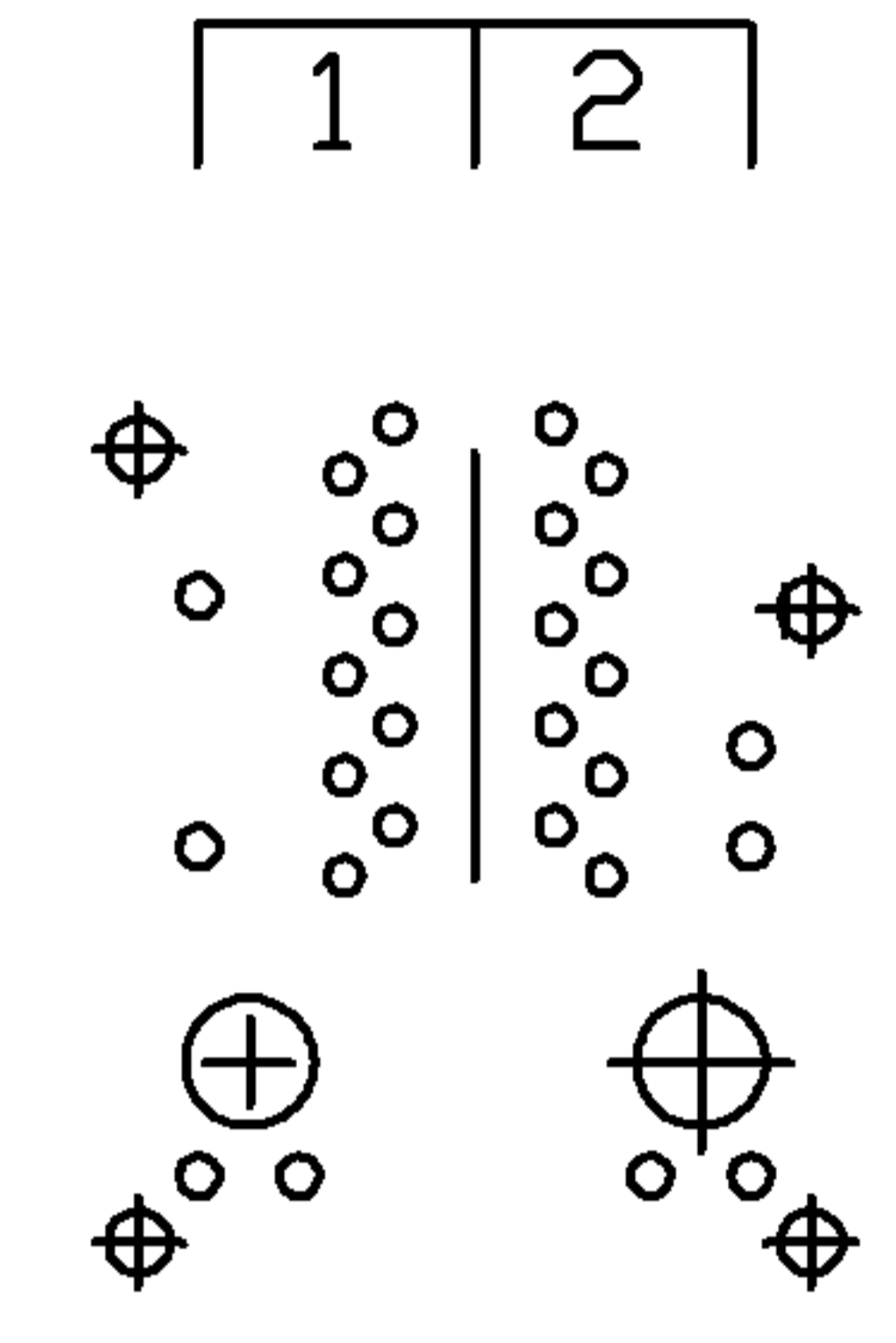

PIN-OUT INFORMATION
(COMPONENT SIDE VIEW)

14	YELLOW+/GREEN-
13	GREEN+/YELLOW-
12	GREEN LED -
11	GREEN LED +
10	GND
9	TRDCT1/2/3/4
8	TRD 4+
7	TRD 4-
6	TRD 3+
5	TRD 3-
4	TRD 2+
3	TRD 2-
2	TRD 1+
1	TRD 1-

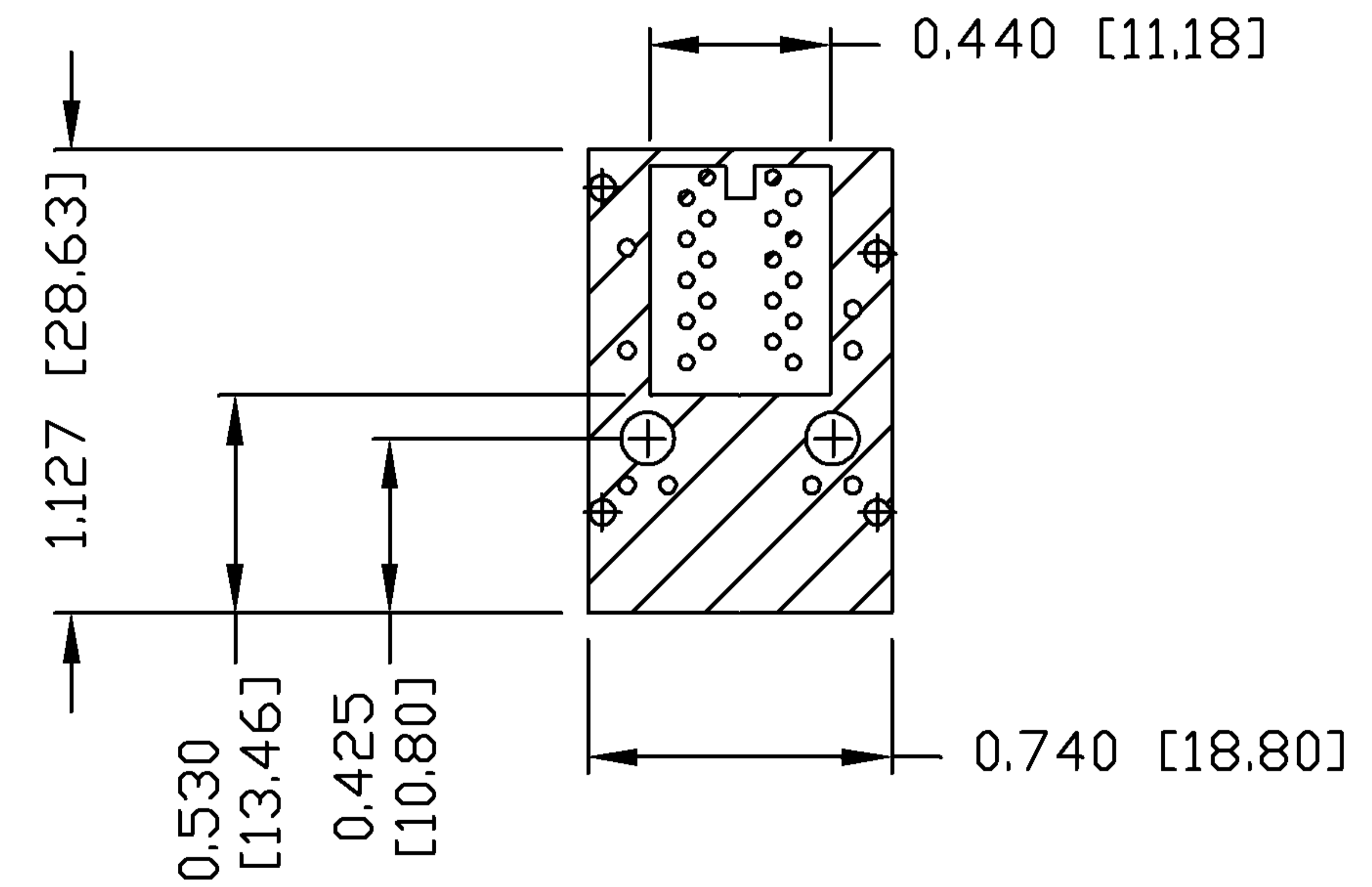

THE SHADED AREA ON THE CUSTOMER BOARD ARE RECOMMENDED TO BE CLEAR OFF ANY VIA HOLE OR COMPONENT PAD.

ORIGINATED BY DAVID CAO	DATE 11-29-08	TITLE 2X1 gigabit MagJack® WITH UPPER AND LOWER LED (8 Cores)	PART NO. / DRAWING NO. 0879-2L1R-Y6	STANDARD DIM. TOL. IN INCH	[] METRIC DIM. AS REFERENCE
DRAWN BY LU XUEPING	DATE 11-29-08		FILE NAME 0879-2L1R-Y6_PB.DWG	.X .XX .XXX	±0.004

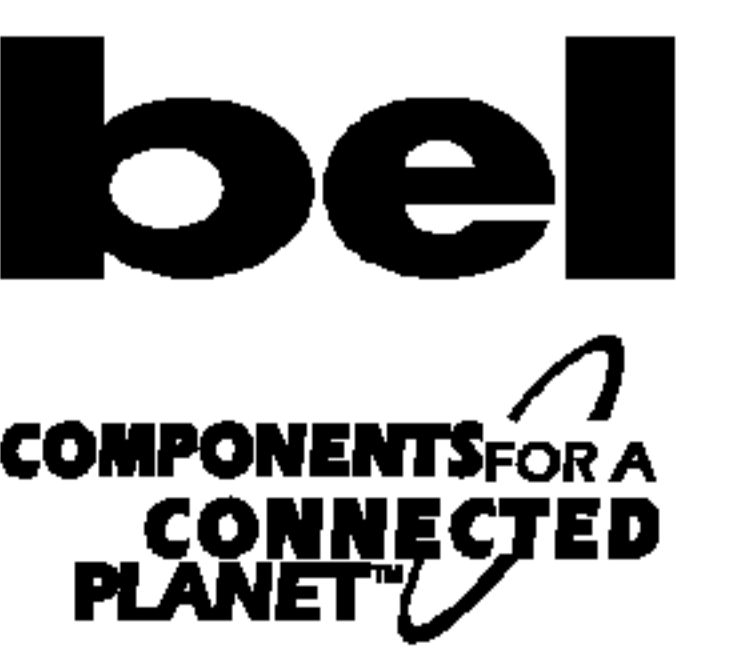

THE INFORMATION CONTAINED HEREIN IS CONSIDERED "PROPRIETARY" TO BEL FUSE INC. AND SHALL NOT BE COPIED, REPRODUCED OR DISCLOSED WITHOUT THE WRITTEN APPROVAL OF BEL FUSE INC.

PRELIMINARY

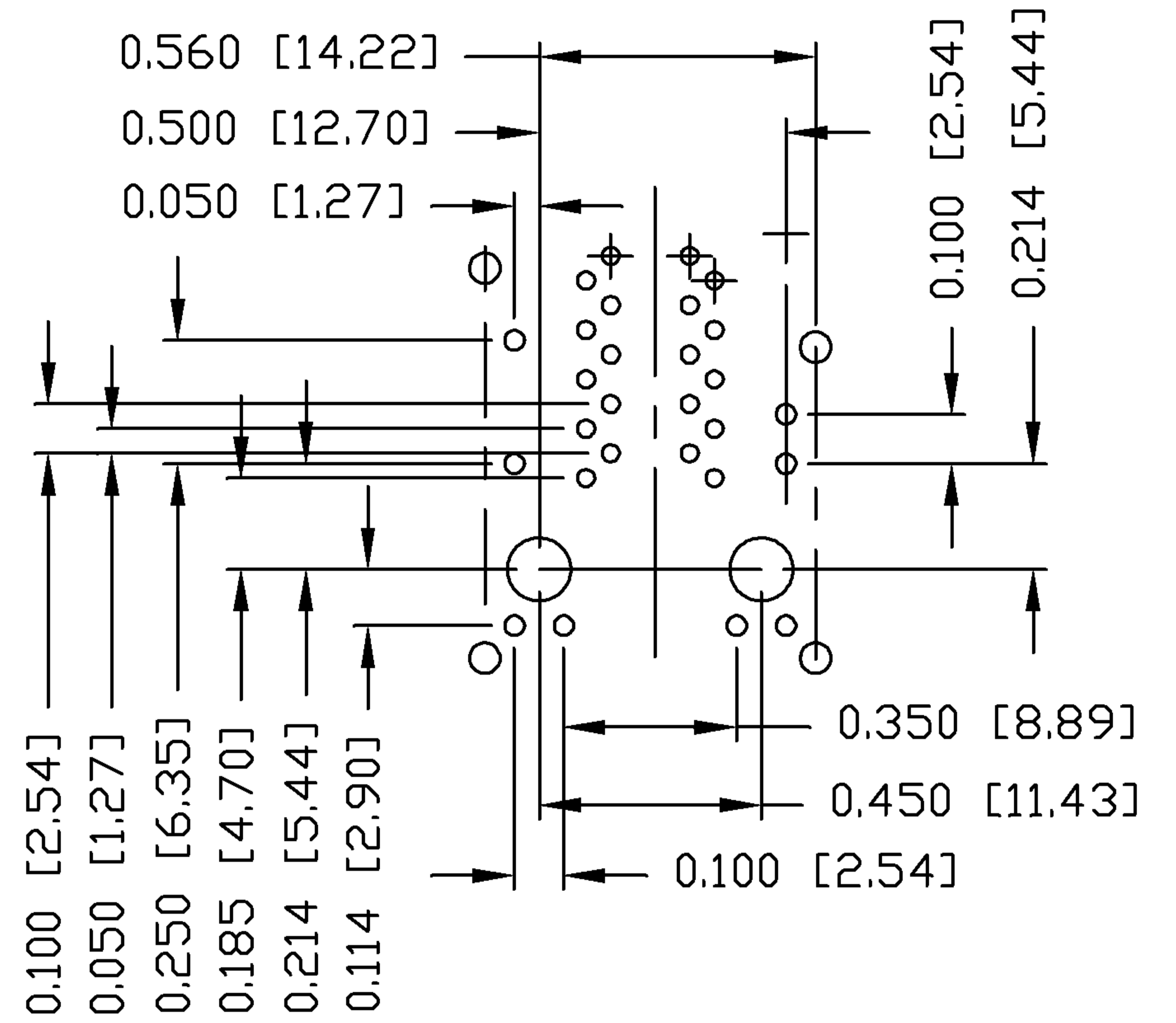
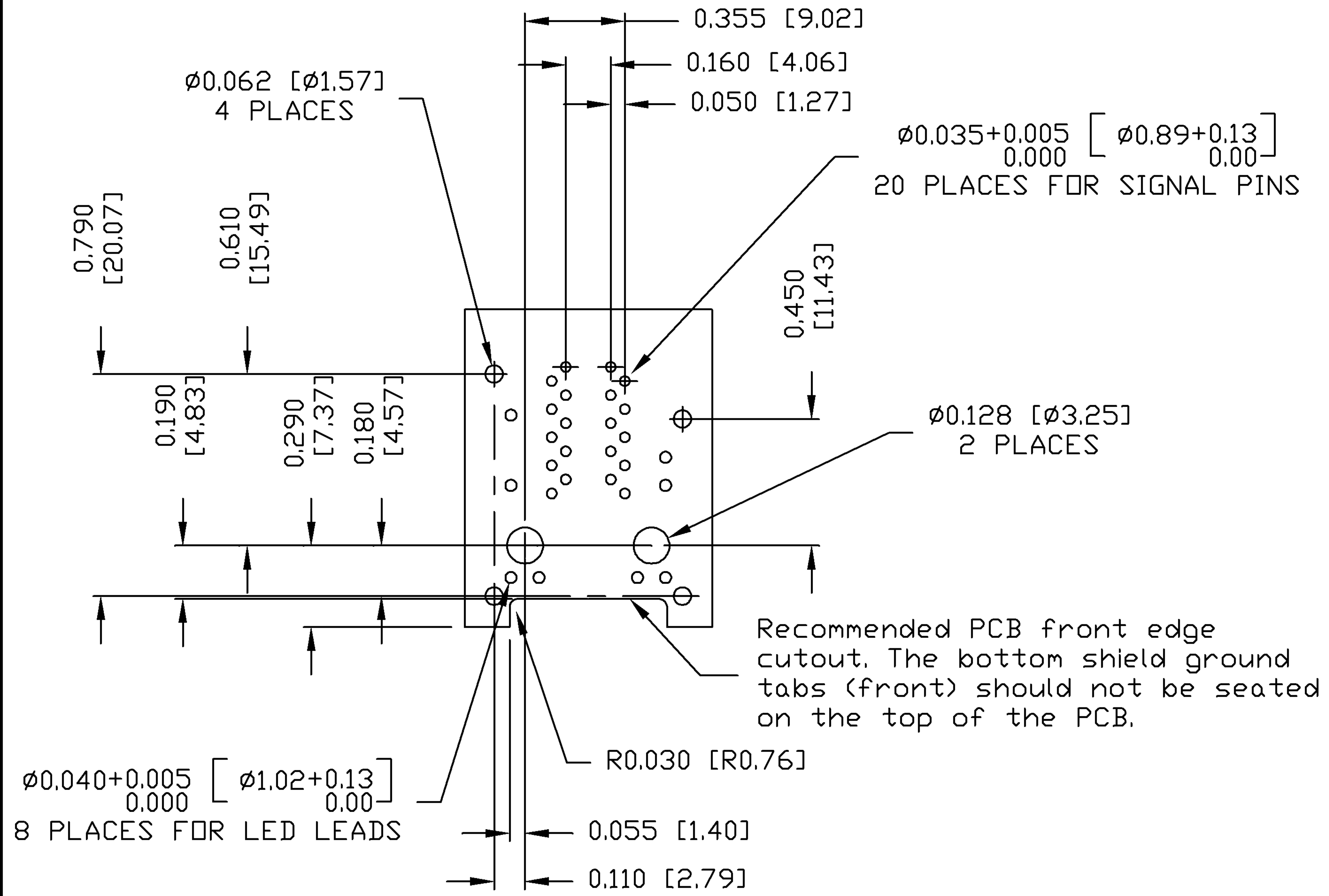

SUGGESTED FOOTPRINT
(COMPONENT SIDE VIEW)

ORIGINATED BY DAVID CAO	DATE 11-29-08	TITLE 2X1 gigabit MagJack® WITH UPPER AND LOWER LED (8 Cores)	PART NO. / DRAWING NO. 0879-2L1R-Y6	STANDARD DIM. TOL. IN INCH	[] METRIC DIM. AS REFERENCE	 COMPONENTS FOR A CONNECTED PLANET	
DRAWN BY LU XUEPING	DATE 11-29-08	FILE NAME 0879-2L1R-Y6_PB.DWG	.X	/	UNIT : INCH [mm]		REV. : PB
			.XX	/	SCALE : N/A		SIZE : A4
			.XXX	±0.004			PAGE : 5

THE INFORMATION CONTAINED HEREIN IS CONSIDERED "PROPRIETARY" TO BEL FUSE INC. AND SHALL NOT BE COPIED, REPRODUCED OR DISCLOSED WITHOUT THE WRITTEN APPROVAL OF BEL FUSE INC.

PRELIMINARY



SUGGESTED PANEL OPENING

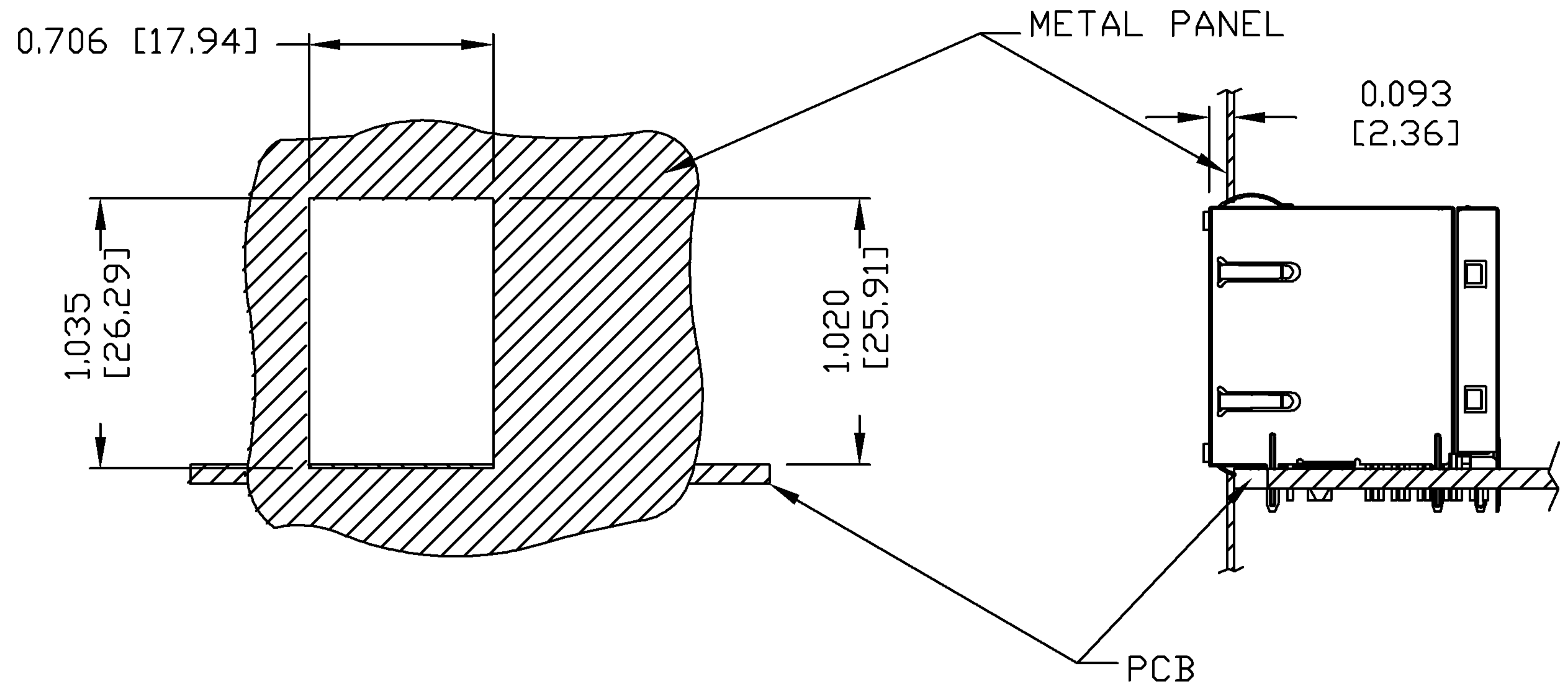

NOTE:

THE DISTANCE OF PANEL INSIDE SURFACE RELATIVE TO FRONT SURFACE OF PART IS ONLY A SUGGESTION. IN CASE THIS DISTANCE IS DIFFERENT, THE REQUIRED PANEL OPENING DIMENSIONS CHANGE ACCORDINGLY.

PACKING INFORMATION

PACKING TRAY : 0200-9999-P8 (TOP)
0200-9999-P9 (BOTTOM)

PACKING QUANTITY : 40 PCS FINISHED GOODS PER TRAY
7 TRAYS (280 PCS FINISHED GOODS) PER CARTON BOX

NOTE : CARDBOARDS ARE PLACED BETWEEN LAYERS OF PACKING TRAY INSIDE CARTON BOX
(INCLUDE THE UPPERMOST AND LOWERMOST TRAY)

ORIGINATED BY DAVID CAO	DATE 11-29-08	TITLE 2X1 gigabit MagJack® WITH UPPER AND LOWER LED (8 Cores)	PART NO. / DRAWING NO. 0879-2L1R-Y6	STANDARD DIM.		[] METRIC DIM. AS REFERENCE		bel COMPONENTS FOR A CONNECTED PLANET
				TOL. IN INCH		UNIT : INCH [mm]	REV. : PB	
DRAWN BY LU XUEPING	DATE 11-29-08		FILE NAME 0879-2L1R-Y6_PB.DWG	.X	/	SCALE : N/A	SIZE : A4	
				.XX				
				.XXX	±0.004		PAGE : 6	