

PRELIMINARY SPEC

RGB Color Sensor

KPS-5130PD7C

Description

•The KPS-5130PD7C Color Sensor Device, consisting of 3-Channel/1Chip (R, G, B) Si photodiode, is a good effective solution to color balance of display backlighting appliances.

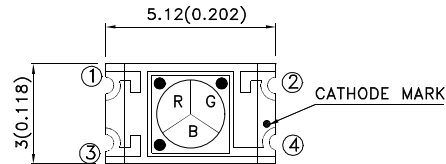

Features

- *Lead-free package.
- *Component in accordance with RoHS.
- *SMD style package on PCB technology.
- *Integral Color Filter in Blue, Green, or Red.
- * Package: 1.5KPCS/Reel.
- * RoHS Compliant.

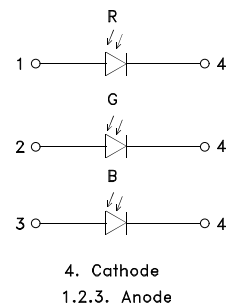
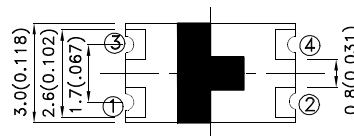
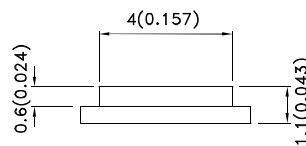

*Applications

The devices are suitable for :

- *colorimetry.
- *printing process control.
- *display color correction.

UNIT : MM[INCH]

TOLERANCE : ±0.1[± 0.004] UNLESS OTHERWISE NOTED.

*Absolute Maximum Ratings(Ta=25°C unless otherwise specified)

Parameter	Symbol	Value	Unit
Reverse Voltage	V_R	10	V
Operating Temperature	T_{opr}	-40~+85	°C
Storage Temperature	T_{sto}	-40~+85	°C
Soldering Temperature	T_{sd}	260	°C



***Electro-optical Characteristics(Ta=25°C unless otherwise specified)**

Parameter	Symbol	Condition	Value			Unit	
			Min.	Typ	Max.		
Peak Sensitivity Wavelength	λ_p	Red	-	620	-	nm	
		Green	-	550	-		
		Blue	-	470	-		
Light Current(1)	I_{L1}	100Lux [1] VR = 5V	Red	-	0.039	-	uA
			Green	-	0.042	-	
			Blue	-	0.022	-	
Light Current(2)	I_{L2}	1000Lux [1] VR = 5V	Red	-	0.427	-	uA
			Green	-	0.498	-	
			Blue	-	0.262	-	
Diameter of the irradiation sensitive area	D		-	2.0	-	mm	
Irradiation sensitive area per element	A		-	0.85	-	mm ²	
Photo sensibility of the single color areas	S_{Max}	$\lambda_R=620\text{ nm}$ $\lambda_G=550\text{ nm}$ $\lambda_B=470\text{ nm}$	-	0.33 0.25 0.18	-	A/W	
Reverse Dark Current	I_D	VR=5V	-	-	10	nA	

Note:

1.White fluorescent light (Color Temperature = 6500K) is used as light source.

Fig.1 Dark Current vs. Ambient Temperature

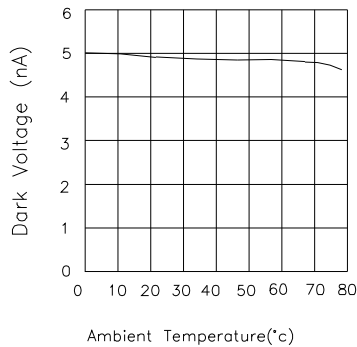

Fig.2 Spectral Response

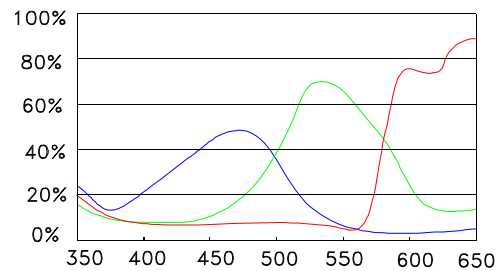
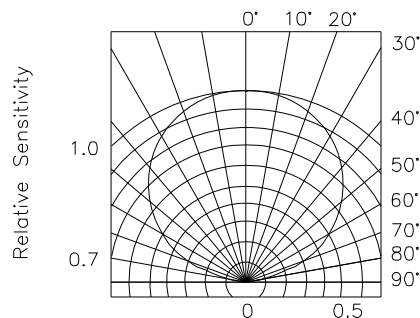

Fig.3 Relative radiant sensitivity vs. Angular displacement



Typical Electro - Optical Characteristics Curves

Fig.4 R,G,B LED Test vs. Output Photocurrent

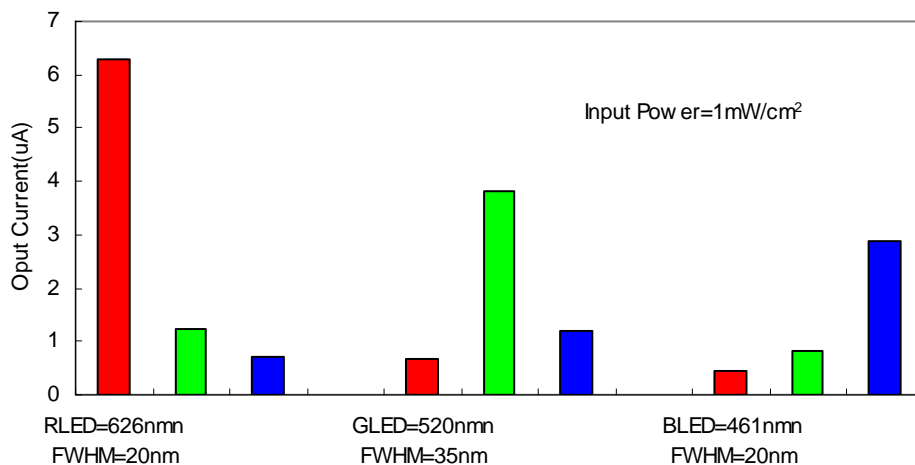
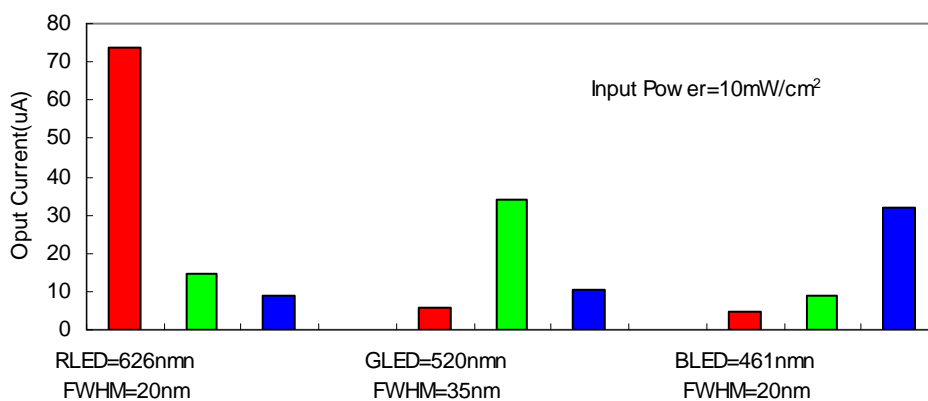
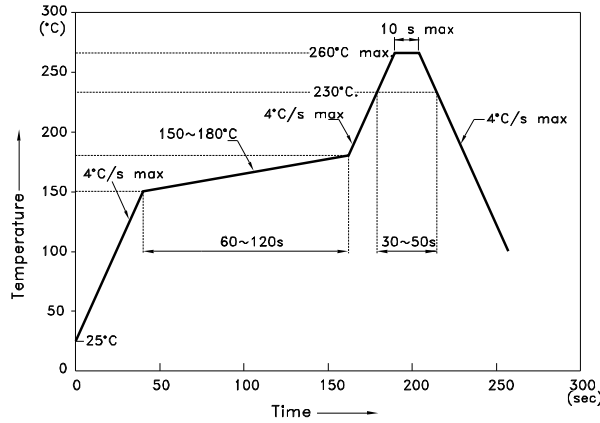

Fig.5 R,G,B LED Test vs. Output Photocurrent



KPS-5130PD7C

Reflow Soldering Profile For Lead-free SMT Process.



NOTES:

1. We recommend the reflow temperature 245°C(+/-5°C). The maximum soldering temperature should be limited to 260°C.
2. Don't cause stress to the epoxy resin while it is exposed to high temperature.
3. Number of reflow process shall be 2 times or less.

Recommended Soldering Pattern (Units : mm; Tolerance: ± 0.1)

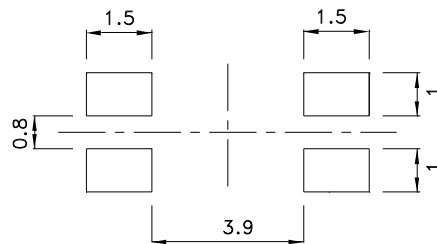

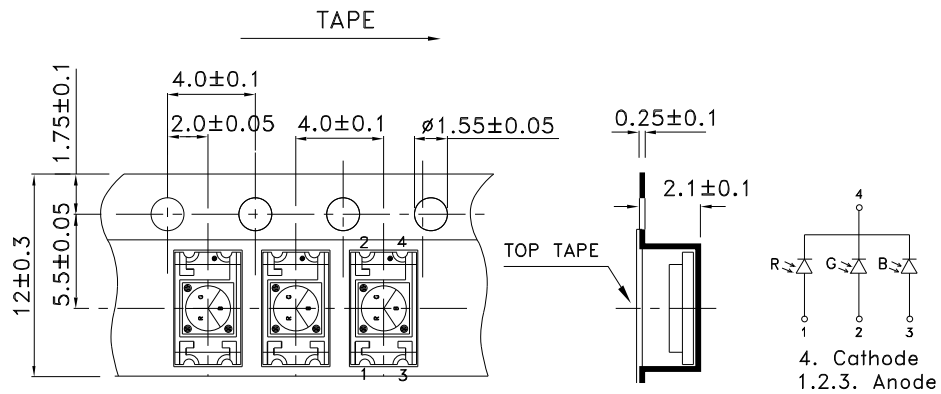

Tape Specifications (Units : mm)

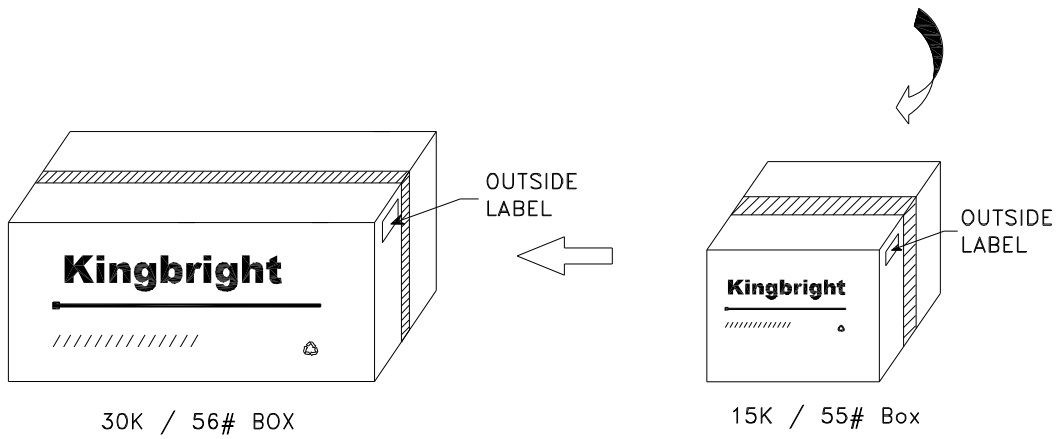
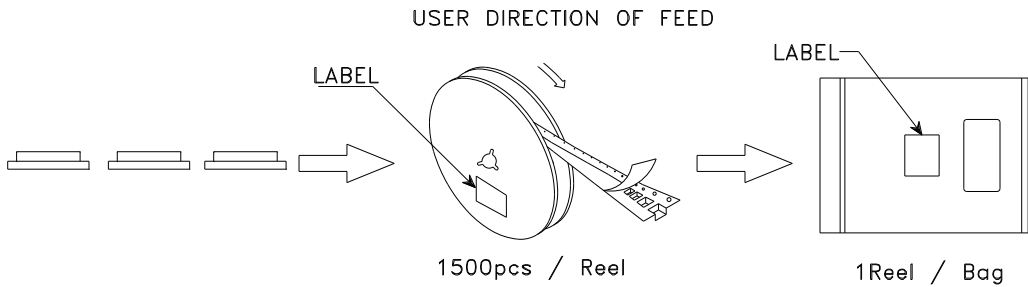

PACKING & LABEL SPECIFICATIONS

KPS-5130PD7C



<h1>Kingbright</h1>	
P/NO: KPS-5130xxx	
QTY: 1.500 pcs	Q.C. Q C XX XX XXXX PASSED
S/N: XXXX	
CODE: XXX	
LOT NO:	
 XXXXXXXXXXXXXXXXXXXXXXXX	
RoHS Compliant	