

Part Number: BLS101SURC-E-28V-P

Hyper Red

### Features

- Built-in current limiting resistor for direct application of different across current.
- Long life.
- Low current, power savings.
- Low maintenance.
- Different color available.
- Solid state, high vibration resistant.
- 28V internal resistor.
- RoHS compliant.

### Description

The Hyper Red source color devices are made with Al-GaNp on GaAs substrate Light Emitting Diode.

### Package Dimensions

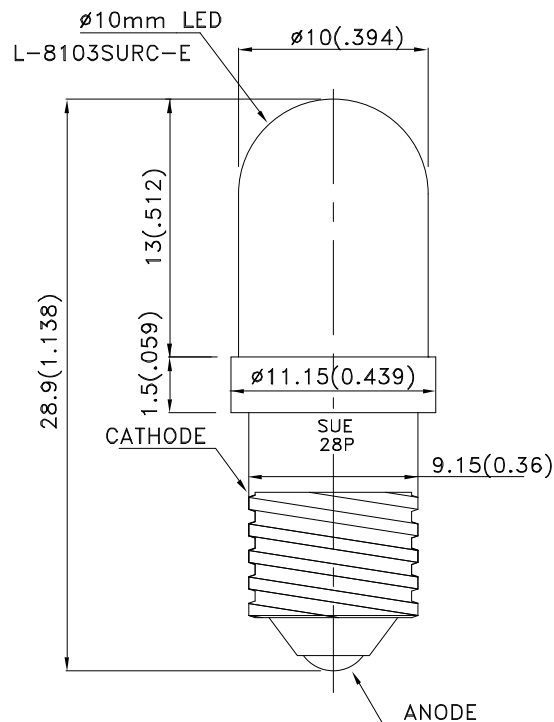

#### Notes:

1. All dimensions are in millimeters (inches).
2. Tolerance is  $\pm 0.25(0.01)$ " unless otherwise noted.
3. The specifications, characteristics and technical data described in the datasheet are subject to change without prior notice.



## Selection Guide

Part No.	Dice	Lens Type	Iv (mcd) V= 28V		Viewing Angle
			Min.	Typ.	2θ1/2
BLS101SURC-E-28V-P	Hyper Red (AlGaInP)	WAWater Clear	700	1600	20°

Notes:

1. θ1/2 is the angle from optical centerline where the luminous intensity is 1/2 of the optical peak value.

## Electrical / Optical Characteristics at TA=25°C

Symbol	Parameter	Device	Typ.	Max.	Units	Test Conditions
$\lambda_{peak}$	Peak Wavelength	Hyper Red	640		nm	V <sub>F</sub> =28V
$\lambda_D$	Dominant Wavelength	Hyper Red	630		nm	V <sub>F</sub> =28V
$\Delta\lambda_{1/2}$	Spectral Line Half-width	Hyper Red	25		nm	V <sub>F</sub> =28V
I <sub>F</sub>	Forward Current	Hyper Red	13	16	mA	V <sub>F</sub> =28V
I <sub>R</sub>	Reverse Current	Hyper Red		10	uA	V <sub>R</sub> = 5V

## Absolute Maximum Ratings at TA=25°C

Parameter	Hyper Red	Units
Power dissipation	480	mW
Forward Voltage	30	V
Reverse Voltage	5	V
Operating Temperature	-40°C To +70°C	
Storage Temperature	-40°C To +85°C	

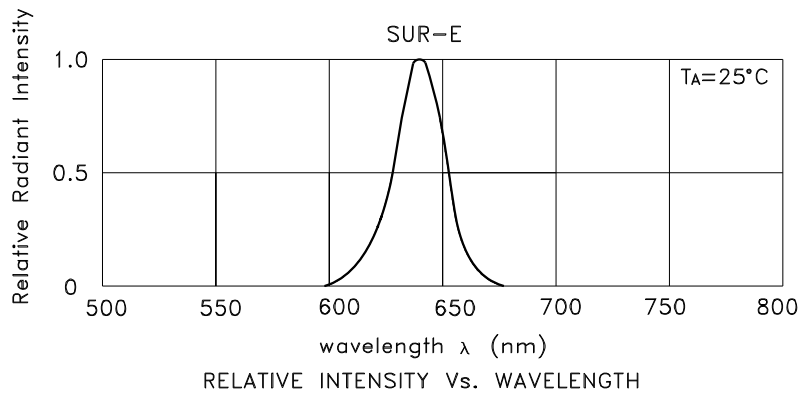

**Super Bright Yellow      BLS101SURC-E-28V-P**

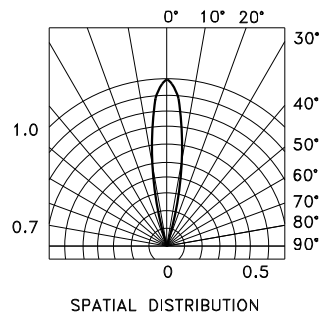
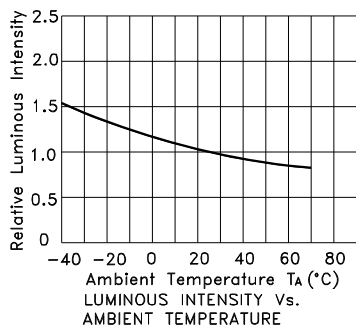
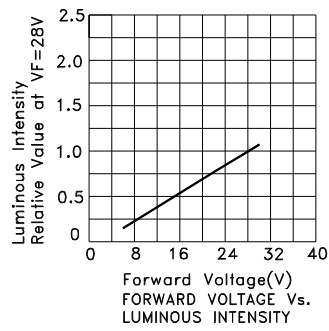
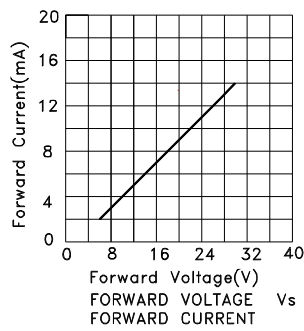

**PACKING & LABEL SPECIFICATIONS**

**BLS101SURC-E-28V-P**

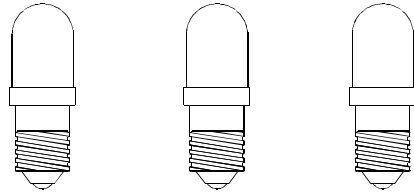

LABEL

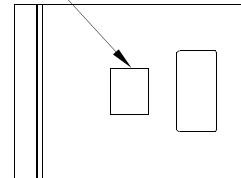

100 PCS / BAG

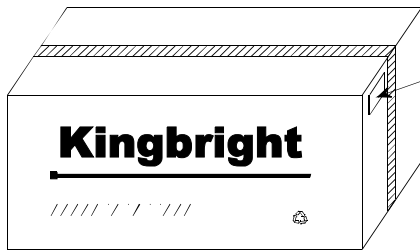

4K/9# BOX

OUTSIDE LABEL



OUTSIDE LABEL

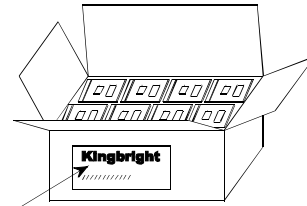

2K/5# BOX

<h1>Kingbright</h1>	
P/NO: BLS101xxx	
QTY: 100 pcs	Q.C. <span style="border: 1px solid black; border-radius: 50%; padding: 2px;">Q C XX XX XXXX PASSED</span>
S/N: XXXX	
CODE: XXX	
LOT NO:	
 xxxxxxxxxxxxxxxxxxxxxxxx	
RoHS Compliant	