

## SUBMINIATURE, HIGH SENSITIVITY PHOTOINTERRUPTER

### \*Features

- Compact and thin.
- Visible light cut-off type.
- High sensitivity.
- RoHS Compliant.

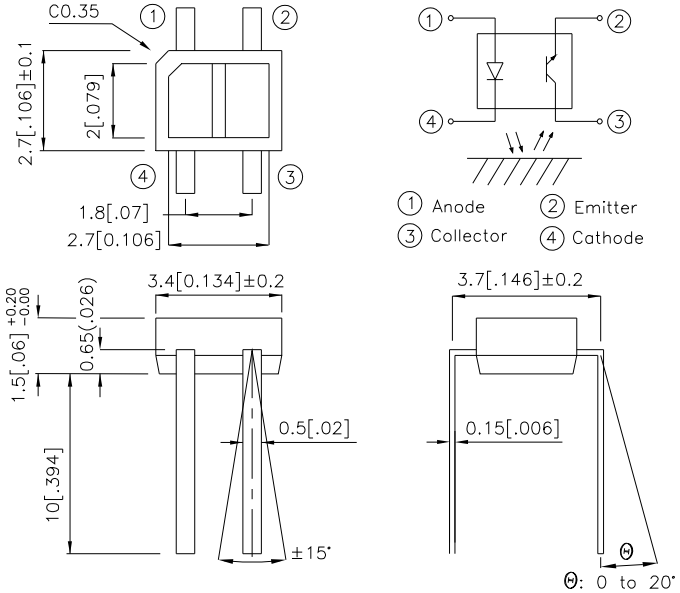

### \*Applications

- Cassette tape recorders, VCRs.
- Floppy disk drives.
- Various microcomputerized control equipment.

UNIT : MM[INCH]

TOLERANCE : ±0.25[± 0.01] UNLESS OTHERWISE NOTED.

### \*Absolute Maximum Ratings $T_a=25^\circ\text{C}$

Parameter		Symbol	Rating	Unit
Input	Forward current	$I_F$	50	mA
	Reverse voltage	$V_R$	6	V
	Power dissipation	$P_d$	75	mW
	Peak Forward Current (Pulse Width $\leq 100\mu\text{s}$ , Duty Cycle = 1%)	$I_{FP}$	1	A
Output	Collector-emitter voltage	$V_{CEO}$	35	V
	Emitter-collector voltage	$V_{ECO}$	6	V
	Collector current	$I_C$	20	mA
	Collector power dissipation	$P_C$	75	mW
Operating temperature		$T_{opr}$	-25~+85	$^\circ\text{C}$
Storage temperature		$T_{stg}$	-40~+100	$^\circ\text{C}$
soldering temperature (1/16 inch from body for 5 seconds)		$T_{sol}$	260	$^\circ\text{C}$



## Electro-optical Characteristics

Parameter		Symbol	Conditions	Min.	TYP.	Max.	Unit	
Input	Forward Voltage	$V_F$	$I_F=20\text{mA}$	1.0	1.2	1.5	V	
	Reverse Current	$I_R$	$V_R=6\text{V}$	-	-	10	$\mu\text{A}$	
	Peak Wavelength	$\lambda_P$	$I_F=20\text{mA}$	-	940	-	nm	
Output	Collector Dark Current	$I_{CEO}$	$V_{CE}=20\text{V}$	-	$10^{-9}$	$10^{-7}$	A	
Transfer characteristics	*1 Collector Current		$I_C$	$V_{CE}=2\text{V}$ $I_F=4\text{mA}$	10	-	400	$\mu\text{A}$
	*2 Leak Current		$I_{LEAK}$	$V_{CE}=2\text{V}$ $I_F=4\text{mA}$	-	-	0.1	$\mu\text{A}$
	Response time	Rise time	$t_r$	$V_{CE}=2\text{V}$ $I_C=100\mu\text{A}$ $R_L=1\text{K}\Omega, d=1\text{mm}$	-	20	100	$\mu\text{sec}$
		Fall time	$t_f$		-	20	100	$\mu\text{sec}$

\*1 The condition and arrangement of the reflective object are shown below.  
 \*2 Without reflective object.

BIN CODE	$I_C$ ( $\mu\text{A}$ )
E	10-120
F	100-250
G	200-400

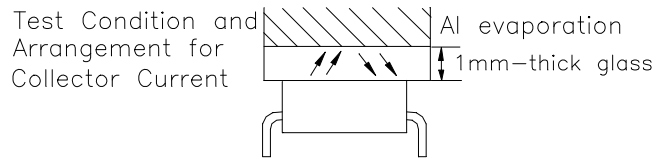

Fig. 1 Forward Current vs. Forward Voltage

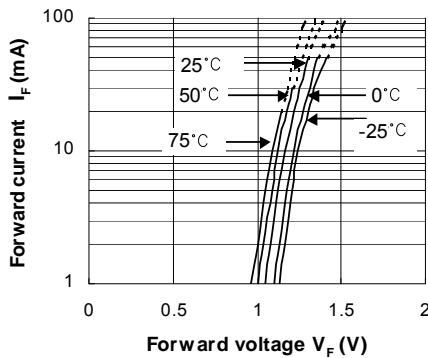

Fig. 3 Collector Current vs. Collector-emitter Voltage

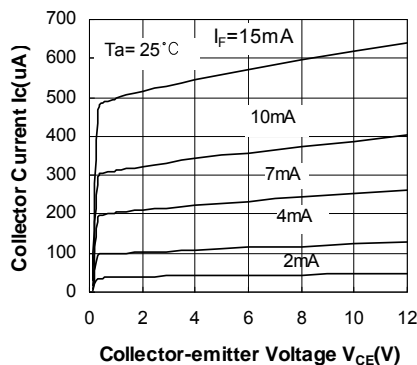

Fig. 2 Collector Current vs. Forward Current

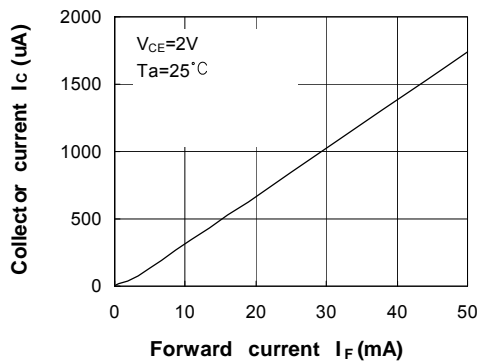

Fig. 4 Relative Collector Current vs. Ambient Temperature

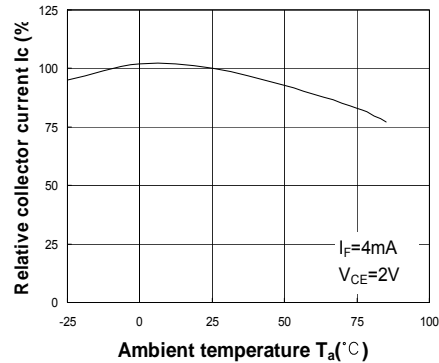
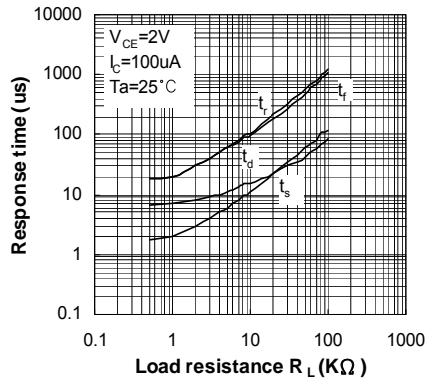

Fig. 5 Response Time vs. Load Resistance



Test Circuit for Response Time

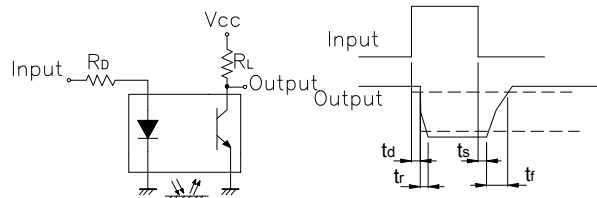

Fig. 6 Collector Dark Current vs. Ambient Temperature

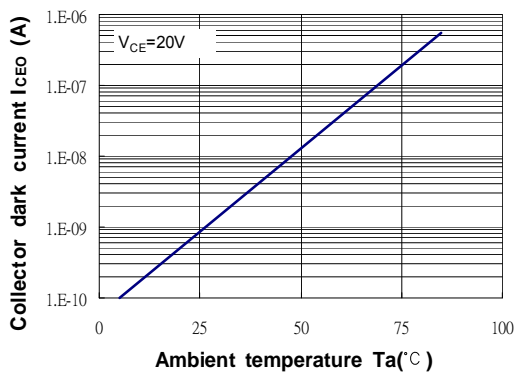

Fig. 7 Relative Collector Current vs. Distance between Sensor and Al Evaporation Glass

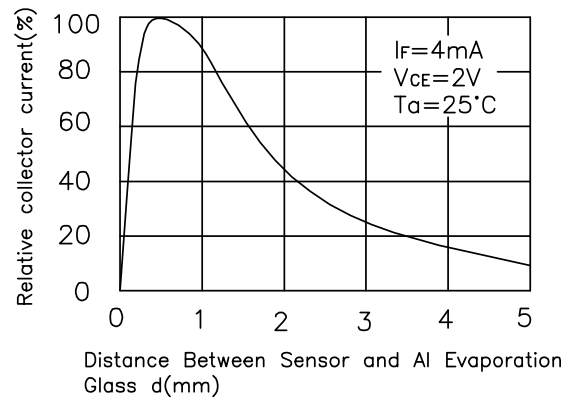

Fig. 8 Relative Collector Current vs. Card Moving Distance (1)

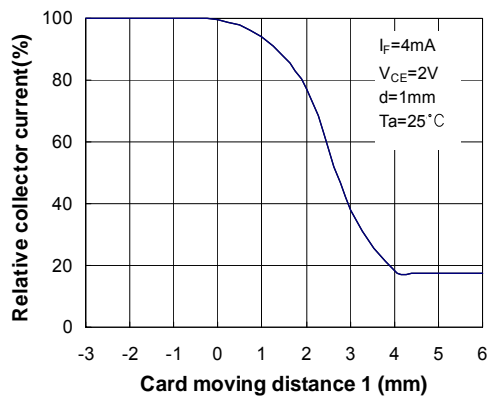
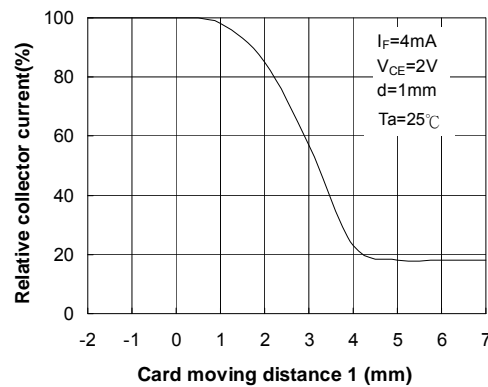
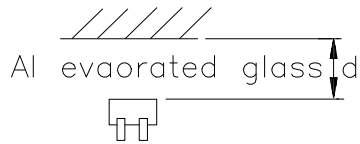

Fig. 9 Relative Collector Current vs. Card Moving Distance (2)



**Test Condition for Distance&Detecting Position Characteristics**

Correpond to Fig. 7



Correpond to Fig. 8  
Test condition

$I_F = 4\text{mA}$   
 $V_{CE} = 2\text{V}$   
 $d = 1\text{mm}$

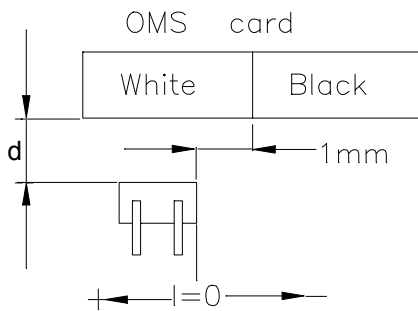

Correpond to Fig. 9  
Test condition

$I_F = 4\text{mA}$   
 $V_{CE} = 2\text{V}$   
 $d = 1\text{mm}$

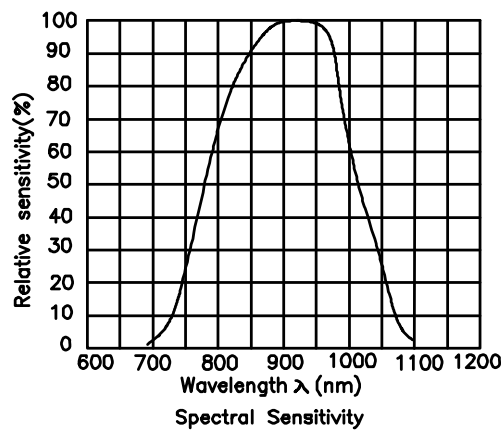
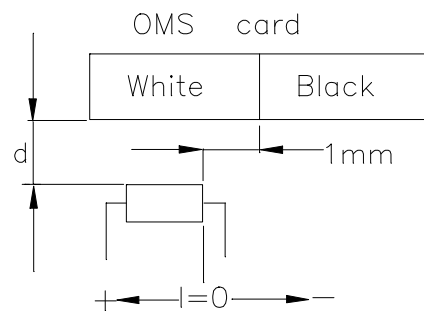

## Wave Soldering Profile

Wave Soldering Profile For Lead-free Through-hole LED.

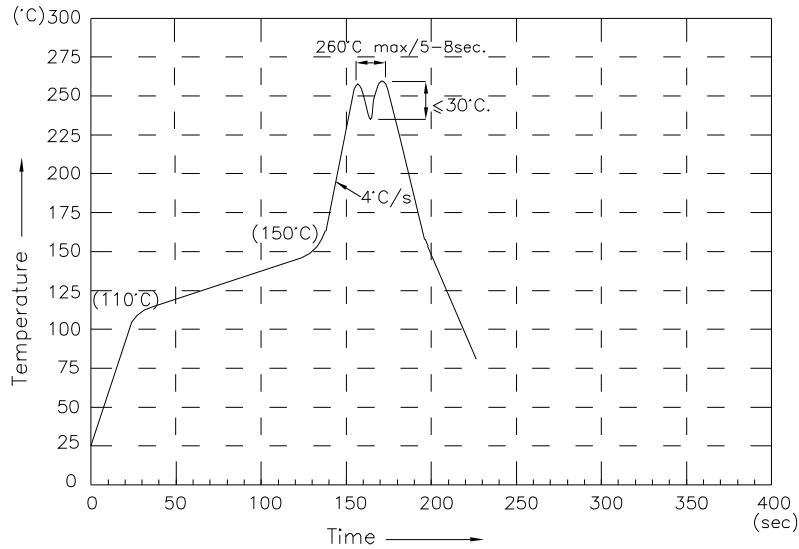



### NOTES:

- 1.Recommend the wave temperature 245°C~260°C.The maximum soldering temperature should be less than 260°C.
- 2.Do not apply stress on epoxy resins when temperature is over 85 degree°C.
- 3.The soldering profile apply to the lead free soldering (Sn/Cu/Ag alloy).
- 4.No more than once.

PACKING & LABEL SPECIFICATIONS

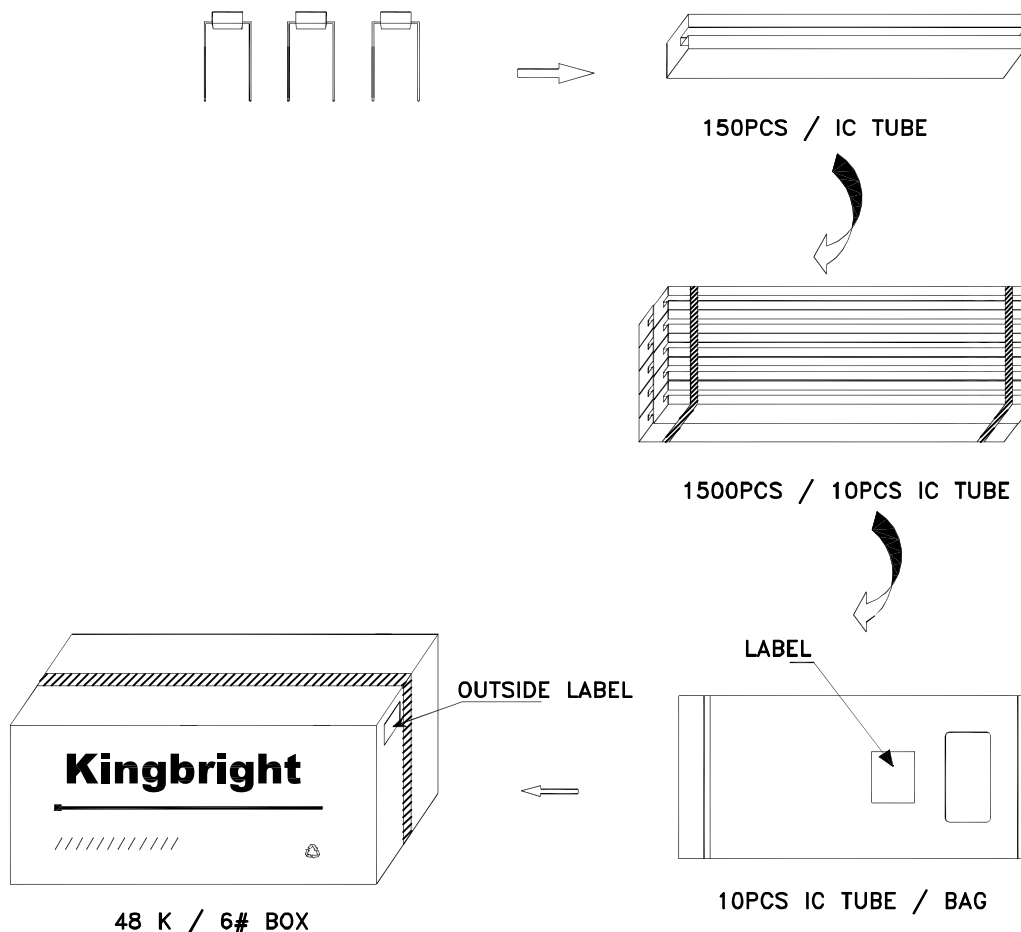
KTIR0811S



<h1>Kingbright</h1>	
P/NO: KTIRxxx	
QTY: 1500 pcs	Q.C. <span style="border: 1px solid black; border-radius: 50%; padding: 2px;">Q C XX XX XXXX PASSED</span>
S/N: XXXX	
CODE: XXX	
LOT NO:	
 XXXXXXXXXXXXXXXXXXXX	
RoHS Compliant	