

Part Number: KM2520EF/4ID-5V

High Efficiency Red

Features

- BLACK CASE ENHANCES CONTRAST.
- VIBRATION AND SHOCK RESISTANT.
- AVAILABLE WITH A VARIETY OF LEDs.
- UL RATING : 94V-0.
- HOUSING MATERIAL: TYPE 66 NYLON.
- 5V INTERNAL RESISTOR.
- RoHS COMPLIANT.

Description

The High Efficiency Red source color devices are made with Gallium Arsenide Phosphide on Gallium Phosphide Orange Light Emitting Diode.

Package Dimensions

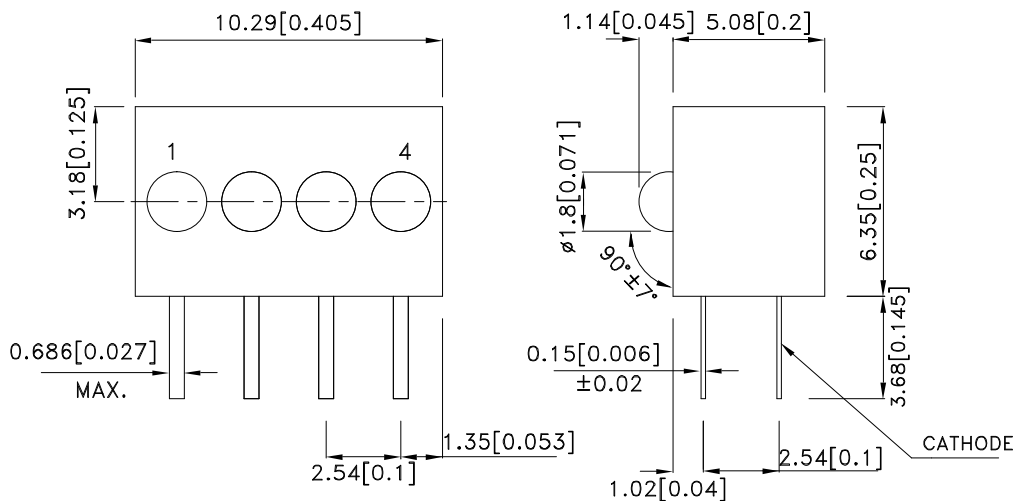

Notes:

1. All dimensions are in millimeters (inches).
2. Tolerance is $\pm 0.25(0.01")$ unless otherwise noted.
3. Lead spacing is measured where the leads emerge from the package.
4. Specifications are subject to change without notice.



Selection Guide

Part No.	Dice	Lens Type	Iv (mcd) [2] V= 5V		Viewing Angle [1]
			Min.	Typ.	2θ1/2
KM2520EF/4ID-5V	High Efficiency Red (GaAsP/GaP)	RED DIFFUSED	1.8	8	40°

Notes:

1. θ1/2 is the angle from optical centerline where the luminous intensity is 1/2 the optical centerline value.
2. Luminous intensity/ luminous Flux: +/-15%.

Electrical / Optical Characteristics at TA=25°C

Symbol	Parameter	Device	Typ.	Max.	Units	Test Conditions
λ_{peak}	Peak Wavelength	High Efficiency Red	627		nm	V _F =5V
λ_D [1]	Dominant Wavelength	High Efficiency Red	625		nm	V _F =5V
$\Delta\lambda_{1/2}$	Spectral Line Half-width	High Efficiency Red	45		nm	V _F =5V
I _F	Forward Current	High Efficiency Red	13	17.5	mA	V _F =5V
I _R	Reverse Current	High Efficiency Red		10	μA	V _R = 5V

Note:

- 1.Wavelength: +/-1nm.

Absolute Maximum Ratings at TA=25°C

Parameter	High Efficiency Red	Units
Power dissipation	85	mW
Forward Voltage	6	V
Reverse Voltage	5	V
Operating Temperature	-40°C To +70°C	
Storage Temperature	-40°C To +85°C	
Lead Solder Temperature [1]	260°C For 3 Seconds	
Lead Solder Temperature [2]	260°C For 5 Seconds	

Notes:

1. 2mm below package base.
2. 5mm below package base.

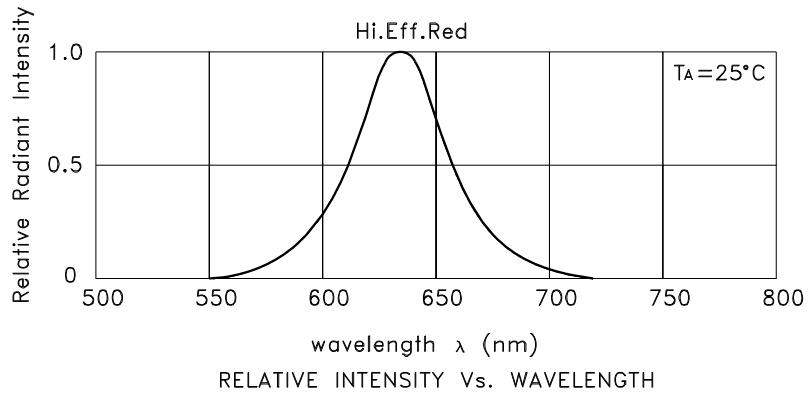

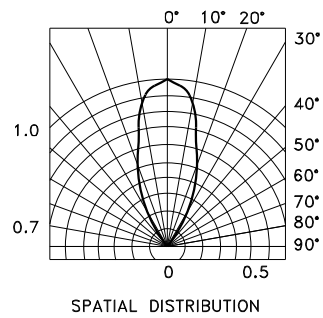
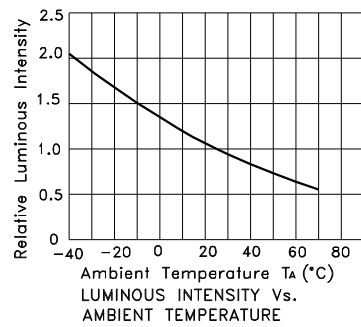
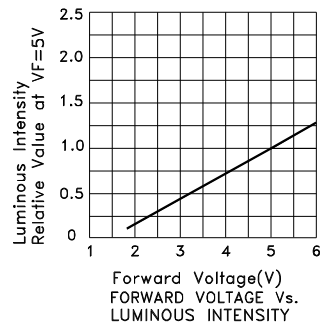
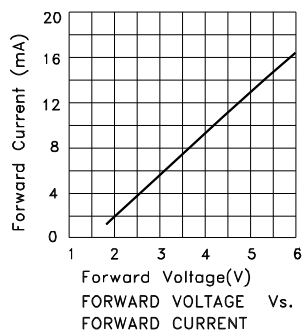

High Efficiency Red KM2520EF/4ID-5V

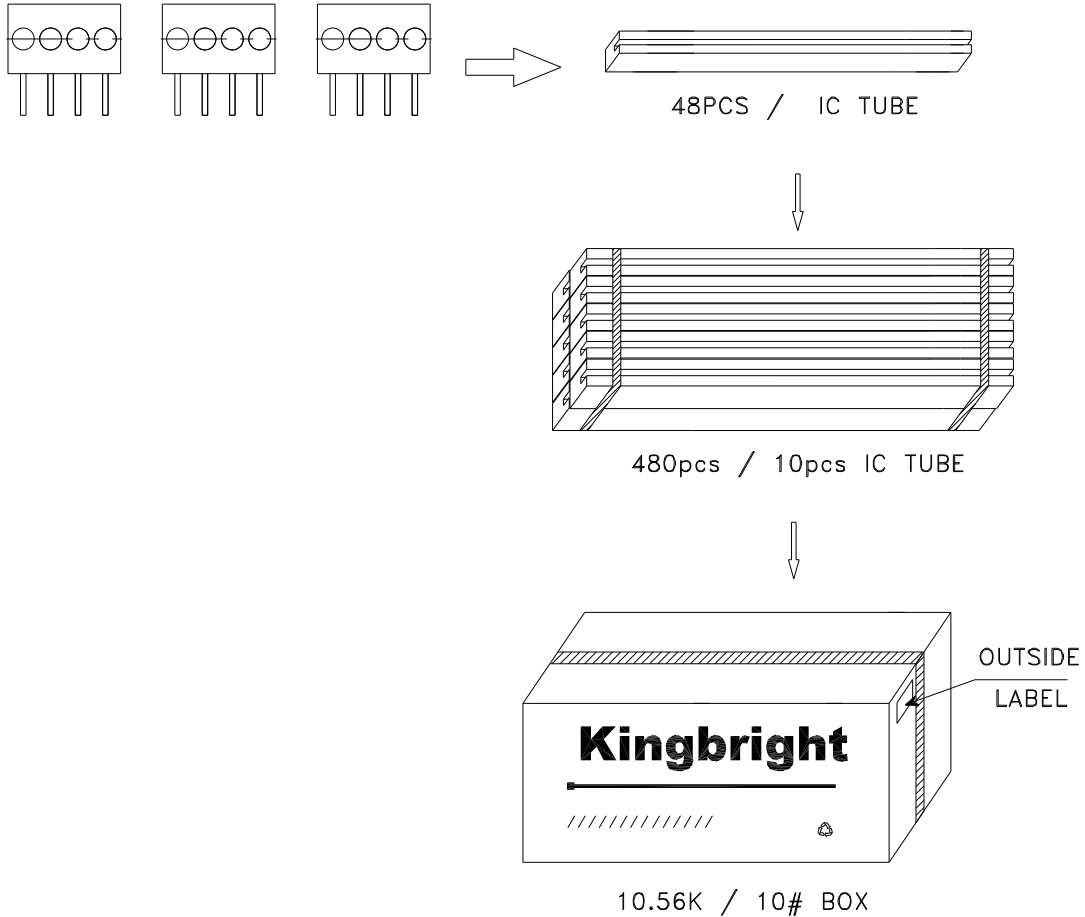

PACKING & LABEL SPECIFICATIONS

KM2520EF/4ID-5V



Kingbright	
Q.C.	QC XX XX XX PASSED
TYPE NO : KM2520EFxxx	
QUANTITY : 480 pcs	
S/N : XX	CODE: XX
LOT NO :  XX-HPXXX	
RoHS Compliant	